

Diversity of metazoan parasite communities in selected fish species from water basins with different degrees of anthropogenic stress

Leszek Rolbiecki<sup>1</sup>

*Department of Invertebrate Zoology, University of Gdańsk,  
Al. Marszałka Piłsudskiego 46, 81-378 Gdynia, Poland*

**Key words:** parasitic metazoan community, diversity, richness, anthropogenic stress, lake exploited by hydroelectric plant, roach *Rutilus rutilus*, European perch *Perca fluviatilis*, Lake Żarnowieckie, Lake Raduńskie Dolne, Poland

**Abstract**

Parasite communities of selected animal species from water basins with different degrees and types of anthropogenic stress differ from each other. Fish are a good subject for the study of this issue since they are one of the terminal links of the parasitic succession, and they accumulate many parasites from various parasitic groups. The aim of the study was to analyze metazoan parasite communities in the roach *Rutilus rutilus* and the European perch *Perca fluviatilis*, from two lakes (Żarnowieckie and Raduńskie Dolne) in northern Poland, which are of the same water quality classification, but which are subjected to different degrees and types of anthropogenic stress. Lake Żarnowieckie is exploited as a lower reservoir of the pumped-storage Żarnowiec

---

<sup>1</sup>e-mail address: [l.rolbiecki@ug.edu.pl](mailto:l.rolbiecki@ug.edu.pl)

Hydropower Plant. Lake Raduńskie Dolne is used primarily for recreation and tourism, and it exhibits symptoms of progressive eutrophication. During the period between the spring of 2006 and the fall of 2008, 607 European perch specimens (307 from Lake Żarnowieckie and 300 from Lake Raduńskie Dolne) and 608 roach specimens (305 and 303, respectively) were examined. The study focused on Metazoa to the exclusion of Myxozoa. A total of 40 parasite taxa were noted on the fish from Lake Żarnowieckie, while 48 were noted on the fish from Lake Raduńskie Dolne. The European perch from these lakes hosted 22 and 28 parasite taxa, while the roach hosted 25 and 30 taxa in Lakes Żarnowieckie and Raduńskie Dolne, respectively. The larval nematode *Contracaecum*, most of the metacercariae of *Diplostomum* (Digenea) and glochidia of *Unio* (Bivalvia), juvenile tapeworms of the genus *Proteocephalus* and nematomorph *Gordionus* were identified to the genus level. The nematode *Cosmocephalus obvelatus* L3 was recorded as a new species among Polish ichthyofauna. Additionally, the roach inhabiting the Polish regions appears to be a new host for *Diplostomum gaviium* met., while the European perch plays the same role for *Anisakis simplex* L3, *Contracaecum* sp. L3 and *Eustrongylides excisus* L4. The nematode *C. obvelatus* L3 and the nematomorph of the genus *Gordionus* were recorded for the first time on the European perch. The following ecological indices were used to perform a comparative analysis of fish parasite communities: the Shannon-Wiener index; the Pielou index of evenness; the Berger-Parker dominance index. Similarities between fish assemblages were tested by the Jaccard faunistic similarity coefficient and the Steinhaus similarity coefficient. Higher diversity and evenness indices with lower dominance (for all Metazoa) were noted in the fish from Lake Raduńskie Dolne. The values of the ecological indices for most of the parasite community types identified, including ectoparasites, endoparasites, larvae, parasites in adult stages (only in roach), allogenic species, and parasites with complex life cycles (with crustaceans, mollusks, or other invertebrates as the intermediate hosts), were higher in the fish from Lake Raduńskie Dolne. In turn, higher Shannon-Wiener diversity and evenness indices were noted with lower dominance only in the community of adult stage parasites (European perch) and autogenic (European perch and roach) parasites in Lake Żarnowieckie. When the fish species were compared with the Jaccard faunistic similarity index, higher values were recorded for the roach than for the European perch; however, the Steinhaus index was higher for the European perch. Parasitic infection in the European perch and roach from Lake Żarnowieckie was found with the prevalence of 63.2%, the mean intensity of 89.7, and the range of intensity 1-201, and 95.1%, 31.6, 1-115 while in fish from Lake Raduńskie Dolne it was 85.7%, 80.3, 1-394, and 100.0%, 46.6, 1-374. Monogenea were the qualitative dominants in the roach from Lake Żarnowieckie, and Digenea in other fish. In turn, Digenea were always the quantitative dominant in all fish. In the roach from both lakes and the European perch from Lake Raduńskie Dolne, the dominant taxa were the digeneans *Diplostomum* spp. and *Tylodelphys clavata*. While no dominant species was identified in the European perch from Lake Żarnowieckie, digeneans prevailed. For some parasites, correlations were found between their occurrence and the length of the fish and the season of the year. The European perch had a higher condition coefficient (in both infected and uninfected fish) from Lake Żarnowieckie than did the fish from Lake Raduńskie Dolne; however, for the roach (most fish were infected), a higher condition coefficient was noted in the fish from Lake Raduńskie Dolne.

The parasites recorded in the roach and the European perch from Lakes Raduńskie Dolne and Żarnowieckie generally exhibited high species richness, however, the diversity in the latter was both qualitatively and quantitatively lower. It is likely that the construction and operation of the pumped-storage hydroelectric power plant, and particularly the related fluctuation in the water surface area of the lake that regularly exposes a 20-meter-wide strip of the shoreline, have led to the impoverishment of parasite fauna. However, the parasite species richness of fish from Lake Żarnowieckie is currently often comparable or even richer than that observed among fish from many other lakes, which suggests that thirty years after the power plant was put into operation,

both the environmental conditions and the biocenosis composition have stabilized. The higher parasite species diversity in Lake Raduńskie Dolne might indicate its higher degree of eutrophication, which supports the development of parasites.

## INTRODUCTION

Aquatic environments are undergoing extensive transformations as a result of human activities. The range of changes occurring in water basins induced by anthropogenic stress is vast. Basins are adapted to the requirements of communication and transport (i.e. stream regulation, sailing channels). Adequate reserves of water must be created and maintained for consumption, industry and irrigation (i.e. retention reservoirs), and preventative measures have to be taken against flooding (i.e. embankments). Water is also exploited for fishery (i.e. stocking, introduction, adaptation), and for the discharge of various wastewaters from industry, communities and urban areas, agriculture, and tourism. Finally, there is the production of mechanical energy (water mills) or electric energy (hydroelectric power). All of these activities strongly modify and disrupt the natural, dynamic balance of aquatic environments through the transformation of biotic and abiotic properties of ecosystems. These include changes in qualitative and quantitative structures of given biocenoses that influence both free-living and parasitic species.

Among anthropogenic transformations in the physical characteristics of aquatic environments, changes in the dynamics are considered to be of the greatest consequence. Such changes occur when waters are exploited for technical purposes, mainly for the production of energy by hydroelectric plants, including pumped-storage facilities (Lange 1993). The largest plant of this type in Poland is the Żarnowiec Power Plant, which uses Lake Żarnowieckie as its lower retention basin. Many changes occurred in the hydrodynamic regime of the lake when the plant was put into operation in 1983. The volume of water that flows daily from the artificial upper basin to the lake below is about fifteen million cubic meters. This results in daily water level fluctuations of about 1 meter, which are also accompanied by currents and significant water exchange between the lake and the upper basin. One of the consequences of the water level fluctuations is a strip of the shoreline between 10 and 15 m wide, which is alternately submerged and exposed. Additional water currents are created mainly near the plant water uptake/discharge channel into the lake, but this has a positive impact by increasing the water oxygenation (Jarzębińska 1996).

Decreases in the lake surface area, which occur when the power plant is operating, have a negative impact on the flora and fauna inhabiting this lake. Aquatic vegetation, including algae, is destroyed as the water level decreases and it becomes exposed to the air. When the water level increases again, the

resulting detritus contributes to deterioration of the water quality. A variety of animal species live on submerged aquatic vegetation, and when exposed to the air they die from dehydration. Spawning grounds have also been limited, and thus the spawn becomes exposed and desiccates. Fish, including valuable fry, are either injured or killed by hydroelectric plant turbines (Kulik-Kuziemska 1996, RIEP 2002a).

Lake Raduńskie Dolne has not been exploited technically. Thus, the character of the lake is more natural, and it is used mainly for recreation and tourism. There are indications, however, that eutrophication is progressing (RIEP 2002b, Lange and Nowiński 2006).

Fish parasite communities provide important information on the status of aquatic ecosystems. Parasite species richness and diversity, the degree of fish infection, or intensive symptoms of parasite infection are different and depend on the impact of environmental stress. Most studies on the development of fish parasite communities in basins under anthropogenic stress focus on waters that are polluted with communal, agricultural, and industrial wastewaters contaminated with various chemical compounds, including heavy metals (e.g. Sulgostowska 1988, MacKenzie et al. 1995, Khan and Thulin 1999, Sures et al. 1999, Dzika 2003, Valtonen et al. 1994, 2003). Another interesting issue is how salinity fluctuations, which occur when marine or brackish basins are connected by channels to freshwater basins, affect the structure of fish parasite communities (Prost 1959). More and more often, studies focus on analyzing the role of alien parasites that have been introduced through uncontrolled acclimatization or fish introduction (e.g. Pojmańska 1993a, Rolbiecki and Rokicki 2005, Taraschewski 2006).

Few studies focus on analyses of parasite communities in basins exploited for technical purposes. Those generally address the impact on fish parasites of thermal pollution associated with hydroelectric power plants (Overstreet 1993, Pojmańska et al. 1980, Jeżewski 2006). Single studies have also investigated the impact of dams built on rivers (Loot et al. 2007, Bauer and Stolyarov 1970). So far, however, no studies have been conducted, either in Poland or abroad, that would focus on the influence exerted by a functioning pumped-storage hydroelectric power plant on fish parasites.

The aim of the current study was to compare communities of parasites of roach *Rutilus rutilus* (Linnaeus, 1758) and European perch *Perca fluviatilis* Linnaeus, 1758 from two lakes (Żarnowieckie and Raduńskie Dolne) that belong to the same water quality class but suffer from different degrees and types of anthropogenic stress. Roach and European perch are both the terminal links in the life cycles of many different parasite species, and they are common inhabitants of Lakes Żarnowieckie and Raduńskie Dolne. Thus they are used as representative host species for a study. These fish species are also often chosen

for parasitological studies for evaluating the quality of waters subjected to various degrees of anthropogenic stress (e.g. Valtonen et al. 1997, Halmetoja et al. 2000, Dzika 2003).

In 2010, the Polish government made the decision to build a nuclear power plant, and the ranking of possible sites for the facility lists Żarnowiec as the leading candidate location, with Lake Żarnowieckie as the cooling water reservoir. Consequently, the results of the current study will provide foundation material for future studies determining the impact of the plant operation on this lake.

## **MATERIALS AND METHODS**

### ***Description of the study area***

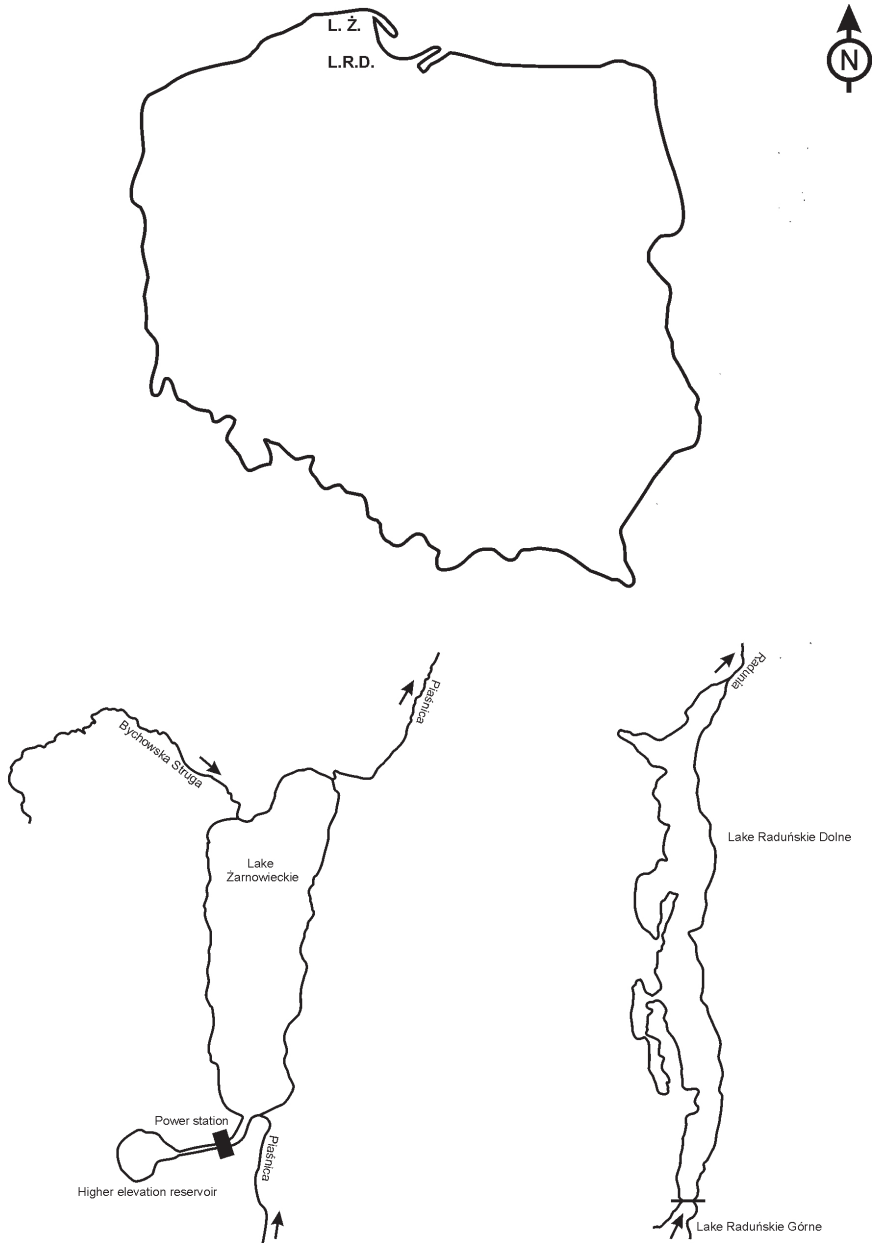
#### *Lake Żarnowieckie*

Lake Żarnowieckie (54°46.0'N/18°03.5'E) is located in the Żarnowiecka Plateau of the Southern Baltic Coastal Region (Kondracki 1994, Jańczak 1997) (Fig. 1).

Lake Żarnowieckie is a post-glacial ribbon lake with a surface area of 1431.6 ha, the average depth of 8.4 m and the maximum depth of 19.4 m (Table 1). In terms of surface area, it is the ninth largest lake in the Pomeranian Lake District (Choiński 2006).

The lake's shoreline is poorly vegetated, and the lake has no bays, peninsulas, or islands. The lake is characterized by cryptodepression with a bottom surface that is 17.9 m below the sea level. The lake is fed by the Piaśnica River (upper and lower reaches) and the Bychawska Stream. The Upper Piaśnica River flows into the lake from the southeast, near the uptake/discharge channel that connects the hydropower plant with the lake. The Lower Piaśnica River, which is the only natural outflow of the lake, flows directly into the Baltic Sea about 5 km downstream at the town of Dąbki. Periodic increases in the water level that can reach 1.5 m above sea level during storms on the Baltic cause backflows on the river that almost reach the lake. A weir was constructed at the river mouth to regulate backflows, which limits the impact on the lake (Jarzębińska 1996, Narwojsz 2000).

The vicinity of Lake Żarnowieckie is included in the Żarnowiec-Tczew Special Economic Zone, which means there are a variety of metal, machine, chemical, food processing, building materials, and lumber enterprises active in this area (Zalewski 2000, RIEP 2002a).



**Fig. 1.** Geographical position of Lakes Żarnowieckie (L.Ż.) and Raduńskie Dolne (L.R.D.).

**Table 1**

Morphometric indices of the studied lakes (Jańczak 1997; RIEP 2002a,b; Choiński 2006).

Parametres	Lake Żarnowieckie	Lake Raduńskie Dolne
Macroregion	Koszalin Seashore	East Pomeranian Lakeland
Mesoregion	Żarnowiecka Plateau	Kashubian Lakeland
Drainage area	Piaśnica-Baltic Sea	Radunia-Moława-Dead Vistula- Baltic Sea
Elevation above sea level	1.5	161.3
Longitude	18°03.5'	18°02.7'
Latitude	54°46.0'	54°17.3'
Surface (ha)	1431.6	737.2
Maximal depth (m)	19.4	35.4
Average depth (m)	8.4	11.2
Water volume (tys. m <sup>3</sup> )	120841.4	82522.7
Maximal length (m)	7610	9670
Maximal width (m)	2600	1370
Length of coastal line (m)	18650	31100
Fisheries type	freshwater bream lake	vendace lake

Stretches of mixed forest run along the eastern and western shores of the lake, and there are marshy areas near the mouth of the Bychawska Stream and the inflow and outflow of the Piaśnica River. The submerged vegetation is dominated by pondweed from the families Potamogetonaceae and Characeae. The primary phytoplankton components in Lake Żarnowieckie are diatoms and cyanobacteria (RIEP 2002a). The species composition of the invertebrate fauna in both the lake and the uptake/discharge channel includes sponges, turbellarians, oligochaetes, leeches, snails, bivalves, crustaceans (copepods, isopods, amphipods, cladocerans, ostracods), rotifers, nematomorphs and insects (mayflies, stoneflies, caddisflies, flies, beetles). The dominant taxa in the lake are rotifers and the zebra mussel *Dreissena polymorpha* (Pallas, 1771) among mollusks. In the first two decades, when the hydropower plant was in operation, the degradation of the phytocoenoses of the lake was observed. Additionally, the structure of zooplankton underwent a transformation with the increased overall zooplankton biomass. This was manifested as the increased abundance of predatory Copepoda forms with a simultaneous decrease in the abundance of oligotrophic forms, especially with a distinct decline in the abundance of Cyclopoida. Decreases in the zoobenthos abundance were also observed, as were the decreases in the abundance of fish species. In the period between 1976 and 1982 there were 18 fish species, in the period between 1983 and 1990 – 12 species, and by 1994 there were only nine species (Pliński and Wnorowski 1993, Afanasiew et al. 1996, Kulik-Kuziemska 1996, Tunowski and Murawa 1996, Wilkońska 1996).

In terms of fisheries, Lake Żarnowieckie is a freshwater bream lake. Currently, the lake is dominated by tench *Tinca tinca* (Linnaeus, 1758), roach and European perch (RIEP 2002a). Eel, which is in the highest demand, is a rarity because of the limited access to the Baltic Sea created by the weir on the Lower Piaśnica River.

The lake is used for recreation, and there are several resorts near the lake. Wastewaters from these resorts are directed to local treatment plants, while those from the eastern shore, the hydropower plant and the Żarnowiec-Tczew Special Economic Zone are treated at the treatment facility in the town of Lubkowo, before they are released into the Piaśnica River and then the lake. Communal wastewaters from the western shore are treated in the town of Nadole, and then released into the lake (RIEP 2002a).

Lake Żarnowieckie is classified as purity class II and the sanitary status of class I (as of 2002) (Boruchalska et al. 2003). Detailed morphometric and physicochemical indices for the lake are presented in Tables 1 and 2.

The pumped-storage hydroelectric power plant is located on the southern end of the lake in the town of Czymanowo. The plant was put into operation in 1983, and it exploits Lake Żarnowieckie as its lower reservoir. The Żarnowiec hydropower plant consists of an upper reservoir (artificial reservoir), four pressure pipelines (1100 m in length and from 5.4 to 7.1 m in diameter), the power plant with four reversible units (for the turbines and pumps), and an open uptake/discharge channel (835 m in length) that connects the power plant with Lake Żarnowieckie, which is the lower reservoir (Fig. 1). In the 1970s, there were plans to build a nuclear power plant at this location and to use Lake Żarnowieckie as the cooling reservoir, but financial constraints and a lack of public support meant that the project was abandoned. The unfinished nuclear power plant is located on the southeast shore of the lake about 1200 m from the mouth of the Lower Piaśnica River and 1400 m from the uptake/discharge channel of the pumped-storage hydroelectric plant (Jarzębińska 1996, Jezierski 2005).

### *Lake Raduńskie Dolne*

Lake Raduńskie Dolne (54°17.3'N/18°02.7'E) is located in the drainage basin of the Radunia, Motława, and Dead Vistula Rivers in the central part of the Kashubian Landscape Park in the Pomeranian Lake District (Kondracki 1994, Jańczak 1997) (Fig. 1). Lake Raduńskie Dolne and Lake Raduńskie Górne used to be one basin known as Lake Raduńskie. In 1898, the existing shallows were used to construct an embankment with a bridge that divided the existing lake into two basins, which remain divided until today by a narrow strip (Gołębiewski 1976).



**Table 2**

Selected physicochemical indices of the studied lakes (Jańczak 1997, RIEP 2002a,b).

Parametres	Lake Żarnowieckie	Lake Raduńskie Dolne
pH	7.6	7.8
COD (mg O <sub>2</sub> dm <sup>-3</sup> )	19.4	18.7
BOD <sub>5</sub> (mg O <sub>2</sub> dm <sup>-3</sup> ) <sup>1</sup>	1.1	1.8
Conductivity (μS cm <sup>-1</sup> )	385	280
Oxidation (mg O <sub>2</sub> dm <sup>-3</sup> )	3.4	4.1
Calcium (mg Ca dm <sup>-3</sup> )	52.8	42.1
Sulfites (mg SO <sub>4</sub> dm <sup>-3</sup> )	47.0	14.0
Chlorides (mg Cl dm <sup>-3</sup> )	23.0	9.0
Total nitrogen (mg N dm <sup>-3</sup> )	0.9	0.6
Chlorophyl a (mg dm <sup>-3</sup> )	5.6	10.4
Total phosphorus (mg P dm <sup>-3</sup> )	0.063	0.158
Average oxygenation of hypolimnion (%)	3.7	3.4
Visibility of Secchi disc (m)	3.1	2.4
Class purity <sup>2</sup>	II	II
Sanitary status <sup>2</sup>	I	I
Trophic type	eutrophic	eutrophic

COD: the chemical oxygen demand was determined with the dichromate method, used to evaluate the content of organic substances in the water (Kudelska et al. 1994),

BOD<sub>5</sub>: the five-day biochemical oxygen demand measures the content of organic substances that decompose in the water (Kudelska et al. 1994),

<sup>1</sup>: a value measured in the surface water,

<sup>2</sup>: data from 2002

Lake Raduńskie Dolne is the largest basin of the Raduńskie-Ostrzyckie lake complex and the largest lake in the Kashubian Landscape Park. It is the twentieth largest lake in the Pomeranian Lake District in terms of the surface area. It is a deep lake with an elongated shape. The surface area of the lake is 737.2 ha, and its maximum depth is 35.4 m with the average depth of 11.2 m (Table 1). The main flow into the lake comes from the Radunia River and Lake Raduńskie Górne, and to a lesser extent from the Łączyńska Stream, two smaller streams, and a variety of periodic inflows. The lake outflow is through the Radunia River in the northeast into Lake Kłodno (RIEP 2002b, Choiński 2006, Maślanka and Barańczuk 2007).

The lake has two peninsulas that form distinct bays. The shores of the lake are forested primarily by beech with some hornbeam and alder, and communities appropriate for alders. There is no rural development in the immediate vicinity of the lake, but the prevailing part of the upland terrain around the lake is used for agriculture. The immediate vicinity of the lake is used mainly by individual tourists. Several tourist resorts and numerous summer houses are also located on the lake shores. The lake is a part of a kayaking

route, and there are hiking trails around the lake. The land within the lake drainage basin is exploited for agriculture, tourism and recreation, which all together mean that the excess nutrient loads are supplied to the lake, which in turn supports the progressive eutrophication (Maślanka and Barańczuk 2007).

The phytoplankton of Lake Raduńskie Dolne is dominated by diatoms and cyanobacteria (RIEP 2002b). The lake has relatively rich vegetation that is dominated by Canadian waterweed *Elodea canadensis* Michaux, 1803. Other common vegetation species include rigid hornwort *Ceratophyllum demersum* Linnaeus, 1753; white water crowfoot *Batrachium circinatum* (Sibthorp, 1794); flat stalked pondweed *Potamogeton mucronatus* Schrader ex Sonder, 1850; and perfoliate pondweed *P. perfoliatus* Linnaeus, 1753. Common water moss *Fontinalis antipyretica* Hedwig, 1801 and water-soldier *Stratiotes aloides* Linnaeus, 1753 occur sporadically. Charophyceae, a taxon of green algae, is also common in the lake (Bociąg 2006).

Although the invertebrate species composition has not been studied systematically, it is represented mainly by nematodes and copepods, as well as rotifers, cladocerans, ostracods, isopods, annelids (oligochaetes, leeches), mollusks, turbellarians and insects. One of the dominating species is the zebra mussel (RIEP 2002b, Wojtasik 2007).

In terms of fisheries, Lake Raduńskie Dolne is a vendace lake. The dominant fish species in the lake include the european whitefish *Coregonus lavaretus* (Linnaeus, 1758), vendace *Coregonus albula* (Linnaeus, 1758), freshwater bream *Abramis brama* (Linnaeus, 1758), tench, roach, Crucian carp *Carassius carassius* (Linnaeus, 1758), European perch, northern pike *Esox lucius* Linnaeus, 1758, European eel *Anguilla anguilla* (Linnaeus, 1758), and sometimes common carp *Cyprinus carpio carpio* Linnaeus, 1758. The decreased contribution of eel in the fish species structure of the lake is a disturbing phenomenon (RIEP 2002b, Czerwiński and Wołos 2006).

Lake Raduńskie Dolne is a dimictic lake, which means that there is water mixing down to the bottom in spring and fall, and thermal stratification in summer. The waters of this lake are classified as purity class II with a sanitary status of class I (as of 2002) (Boruchalska et al. 2003, Maślanka and Barańczuk 2007). The detailed morphometric and physicochemical indices regarding the lake are presented in Tables 1 and 2.

### ***Description of the studied fish***

Roach is a member of the family Cyprinidae. This fish grows to an average length of 20-35 cm (maximum 44 cm) and can weigh more than 2 kg. Roach has a low, broad body with short fins placed at regular intervals, and a deeply forked tail. The eyes are large, and the mouth is placed on the same horizontal

plane as the posterior end of the body. The dorsal fin has a small base that is on the same vertical line as the pelvic fins. The lateral line slightly bends down and runs just beneath the middle of the lateral surface of the body. On the abdominal ridge, between the pectoral fins and the anus, there is a keel formed of scales accumulated from both sides of the body. The coloring of roach is variable, with the dorsal section in dark blue-gray or olive green, the sides are silver, and the abdomen turns to white. The pectoral and anal fins are either red or red-orange. The iris of the eye is either entirely red or just the top half is red.

This species is known to have a wide range of variation in morphological characteristics of both the shape and coloring.

Roach males achieve sexual maturity at the age of 2-3 years with the body length of less than 10 cm. Females usually mature one year later after they exceed the length of 10 cm. During the period prior to spawning, males sport a rash on their head and anterior, dorsal sections of their body. Roach spawns in northern Poland in late April and May. Eggs are released on the vegetation substrate in shallow (0.15-1 m), calm waters that are sheltered from wind.

Larval roach consume phytoplankton and minute zooplankton (rotifers, cladocerans, copepods). Roach fry consume larger cladocerans, larval Chironomidae, green algae and detritus. In natural conditions, roach eat Canadian waterweed, stoneworts *Characeae*, rigid hornwort *Ceratophyllum demersum*, duckweed *Lemna trisulca* Linnaeus, 1753, or fennel pondweed *Potamogeton pectinatus* (Linnaeus, 1753). After reaching the length of 15 cm, roach usually have well-developed pharyngeal teeth, which permit them to feed on mollusks (*Valvata*, *Bythynia*, *Pisidium*, *Viviparus*), starting from the zebra mussel. When resources are abundant, the diets of large individuals, exceeding 20 cm in length, are based on mollusks. In strongly eutrophic basins, medium-sized and large individuals periodically (only in summer) shift habitats to open waters where they feed on cladocerans and copepods.

Roach occurs throughout Europe, with the exception of the Iberian, Apennine, and Balkan Peninsulas, Ireland, northern Scotland and Norway, and different sub-species inhabit the drainage basins of the Black, Caspian, and Aral Seas and the Siberian waters.

Roach is highly adaptable to environmental conditions, so it inhabits basins with fresh and brackish waters of various types, with the exception of high mountain streams. Roach is very common in lowlands, and it can be found in lakes that range from oligotrophic to eutrophic, and even dystrophic ones. Younger fish occur in habitats near overgrown shores, where older specimens inhabit the depths of sub-littoral zones.

Roach play an important role in trophic webs of various water basins in which they occur. They play a positive role in the ichthyocenosis as food for other commercially valuable species, but they also have a negative impact as a

factor contributing to water eutrophication. Roach is also used in the manufacture of canned fish products and is sold fresh for immediate consumption (Zalachowski 2000, Krzykowski et al. 2001).

European perch is a member of the family Percidae. This fish grows up to the length of 20-35 cm (maximum 51 cm) and can weigh slightly more than 2 kg. European perch is a moderately long fish with a slightly broadened body that is relatively high. The premaxilla and maxilla intersect with the mandible at the vertical plane of the eye pupil. The mandible is toothed. The operculum has sharp spines, and the posterior and ventral edges of the preoperculum are lined with small ridges. European perch has two dorsal fins. The first one is high with spiny rays, and the second one is lower and shorter with soft rays. The pelvic fins are posterior to the pectoral fins, and the caudal fin is moderately forked. The European perch is covered with ctenoid scales that are secured tightly to the fish skin. The dorsal section of the fish is dark, nearly black with shades of green, while the sides are of lighter shade of steel green, and the abdomen is either light gray or white. The sides of the perch has from six to eight dark, transverse stripes.

The European perch occurs throughout Europe with the exception of Scotland and the southern peninsulas, and northern Asia. The eastern limit of its occurrence is the Kolyma River.

The European perch is a highly adaptable fish species, which explains why it occurs in a wide variety of basin types, both in lotic and lentic fresh and even brackish waters. Younger European perch inhabit the littoral zone, while adult fish usually inhabit the littoral and sub-littoral zones, and are known to swim into open water areas.

Males achieve the first sexual maturity at the age of 1-2 years, while females at the age of 2-4 years. European perch spawn in the inland waters of Poland from mid-April to late May. Spawn is released onto submerged vegetation or bushes, or directly on rocky or gravel substrates.

Hatch of the European perch feed on zooplankton, while perch fry consume larger crustaceans (cladocerans, copepods, water slaters, ostracods, amphipods) and insect larvae (mayflies, odonates, caddisflies, flies), and even water mites. Adult European perch feed on both fish and invertebrates, including cladocerans, copepods, water slaters, gammaridean, *Neomysis*, larval insects, and oligochaetes. Generally, once the European perch attains the length of 15 cm, it begins to feed on fish, which in larger individuals is the principle or the only dietary component. Cannibalism is characteristic of this species, and the European perch preys mainly on roach and smaller European perch.

The European perch plays a significant role in trophic webs of various water basins. When abundant, perch exerts a strong limiting pressure on other valuable species, especially on their fry. Although the European perch is

considered an excellent food fish, it is not a valuable commercial fish (Terlecki 2000, Krzykowski et al. 2001, Froese and Pauly 2011).

### ***Sample collection***

During the period from March 2006 to December 2008 1,215 fish from Lakes Żarnowieckie and Raduńskie Dolne were examined. The fish comprised 607 specimens of European perch (307 from Lake Żarnowieckie and 300 from Lake Raduńskie Dolne) and 608 specimens of roach (305 and 303, respectively). Except for winters of 2006/2007 and 2007/2008 (difficult weather conditions and frozen surface waters, in the winter of 2007/2008 no European perch from Lake Raduńskie Dolne were collected), 30-32 fishes of each species from each lake were sampled in different seasons.

The fish were examined between four and six hours after they were caught. The gill arches were excised from each fish in the field and fixed in 4-5% formaldehyde (Malmberg 1970, Dzika 1987). Before that, leeches and fish lice were collected from gills.

The fish were measured and weighed to the nearest mm and g. The sex of each individual was also determined during dissection. The length distribution and weight of the fish from Lake Żarnowieckie were as follows for roach: 11.7-42.0 (average 21.1) cm, 29-769 (242) g; and for European perch: 9.0-37.0 (21.0) cm, 8-716 (136) g. The corresponding values for the fish from Lake Raduńskie Dolne were as follows for roach: 12.5-35.7 (21.0) cm, 30-616 (201) g; and for European perch: 13.4-35.1 (20.9) cm, 35-487 (128) g.

The sex ratios among the roach and European perch from Lake Żarnowieckie were for females and males – 177, 128 and 195, 112 individuals, respectively. In Lake Raduńskie Dolne, the corresponding data were 169, 134 and 184, 116 individuals.

The fish were sorted by length classes according to growth rates and the number of fish examined: under 15 cm, 15-18 cm, 18.1-21 cm, 21.1-24 cm, 24,1-27 cm, above 27 cm.

### ***Ichthyoparasitological analysis***

The studies focus on metazoan to the exclusion of Myxozoa. In order to confirm the occurrence of parasites, the following organs were examined under a stereo microscope: skin sampled from the fins, the oral cavity, gills, eyes, and internal organs (digestive tract, liver and bile duct, spleen, kidney, heart, gonads, urinary tract, swim bladder). Because of the labor intensity with eye dissections, these organs were stores in saline solution in a refrigerator, where parasites in the eyes survived for as many as several days. Fins, samples of the muscle tissue and most internal organs, including walls of the intestines, the

swim bladder, or ground parenchymatous tissues were also examined after pressing between glass slides in transmitted light.

When there were difficulties in isolation of metacercariae from cysts, artificial digestive juice, consisting of 0.3% HCl, pepsin 0.5% (20-30 min), 0.5% trypsin and 0.85% NaCl (10 min), was used (Pritchard and Kruze 1982).

The gill arches that had been fixed in the field were dissected on Petri dishes with needles and then viewed under a stereo microscope.

Half of the collected Monogenea of the genus *Dactylogyrus* was put into a saturated liquid of ammonium picrate mixed with glycerin (GAP) on the slide, and the other half was transferred to 70% ethanol. Larger monogeneans (Diplozoidae) were preserved in 70% ethanol. Most of the adult digeneans, tapeworms, nematodes, acanthocephalans and nematomorphs were fixed in a mixture of acetic acid and 40% formaldehyde (19:1) and then preserved in 70% ethanol. Metacercariae were sacrificed with hot water, and then they were fixed and preserved in 70% ethanol. The remaining helminths and crustaceans (fish lice, *Caligus*) were fixed and preserved in 70% ethanol. Copepods collected from beforehand formalin-fixed gills were transferred to 70% ethanol. Leeches were first anesthetized in 10% ethanol. After five to ten hours, they were washed in 50% ethanol and preserved in 75% ethanol (Malmberg 1970, Bielecki 1997, Pojmańska and Cielecka 2001, Rolbiecki 2002a, 2007, Niewiadomska 2003, Dzika 2008). The alive glochidia were fixed with hot (85°C) 4% formaldehyde. They were left in this solution as a preservative fluid. Hot 4% formaldehyde usually caused the shells of glochidia mollusks to open. However, it was essential here to clean the shells of the epithelial cysts, which had encased the glochidia. The glochidia collected from the tank bottoms and then treated with hot 4% formaldehyde had always open shells. Some of the glochidia were fixed after they had been held in a saline solution for one to three days in saline solution under refrigeration. Such glochidia opened more easily.

The collected parasites were identified either *in vivo* or after fixing. When necessary, either temporary or permanent microscope slides were prepared. The nematodes were cleared in lactophenol or a solution of glycerin, water and 95% ethanol, after which they were embedded in glycerol-gelatin. Monogeneans were left in the GAP. Some monogeneans were prepared in this manner or cleared in lactophenol, and then embedded in glycerol-gelatin. Larger monogeneans (Diplozoidae), digeneans, tapeworms and acanthocephalans were stained in alcohol-borax carmine, dehydrated in an alcohol range or in glacial acetic acid, and cleared in benzyl alcohol. Some of the parasites were embedded in Canada balsam, or left in benzyl alcohol or 70% ethanol. Glochidia were prepared similarly to helminths, but they were not stained and were only dehydrated in ethanol. Copepods were cleared in lactic acid (Humes and

Gooding 1964, Pritchard and Kruze 1982, Pojmańska and Cielecka 2001, Rolbiecki 2002a, 2007, Niewiadomska 2003, Berland 2005, Grabda-Kazubska and Okulewicz 2005, Dzika 2008). Permanent slides were made of some of the appendages of copepods by embedding them in polyvinyl-lactophenol. The anterior and posterior sections of the nematomorph were cleared in lactophenol.

All measurements were done in millimeters with an ocular micrometer, and drawings were done with a drawing tube. The images were projected onto a black, rather than a white background. Thanks to this, the image was in sharper focus which facilitated the tracing. Additionally, using a black background did not require any additional, strong point sources of light when the overhead lights were dimmed in the room.

### **Rearing**

The identification of the glochidia collected from the fish sampled from the lakes was simplified by the specimens that were obtained from material reared experimentally. In order to conduct the experiment, 20 specimens of the duck mussel *Anodonta anatina* (Linnaeus, 1758), the compressed river mussel *Pseudanodonta complanata* (Rossmässler, 1835) and the swollen river mussel *Unio tumidus* Philipsson 1788, as well as two specimens of painter's mussel *Unio pictorum* (Linnaeus, 1758) were collected from Lake Raduńskie in March and April 2008. Only duck mussels and swollen river mussels were collected from Lake Żarnowieckie. Eighteen specimens of the painter's mussel were also collected from the Vistula River (the vicinity of the village of Kiezmark near Gdańsk). The mussels were placed in shallow tanks (10-12 cm high), which facilitated the contact between the fish and the parasites released on the tank bottom. The tanks were aerated and the water temperature was between 15 and 20°C. The fish used as the hosts were European perch (10.1-12.3 cm) and Crucian carp (5.8-8.9 cm), obtained from sterile rearing. Ten specimens of *A. anatina*, *P. complanata*, *U. pictorum* and *U. tumidus* each were placed in each tank (without ground/sand). Fish (five specimens of each species) were placed in aquariums only after glochidia were released. The control group consisted of the Crucian carp (5 specimens) from sterile rearing.

After a period of one to three months from collection (the beginning of the experiment), the parent mussels were observed to release glochidia into the external environment. The first to release the larvae were *U. pictorum* (1 month after the beginning of the experiment), followed by *P. complanata* (1.5 months), and then *U. tumidus* (1.5-2 months), and lastly *A. anatina* (3 months). During this period, the fish became infected. Two to four days following the observed release of larvae, fish dissections were performed. The fins, skin and gills were

examined with a stereo microscope with reflected or transmitted light. After the samples were prepared, the glochidia were cleaned from the fish tissues.

In the case of the mussels *U. pictorum* (n=10) and *U. tumidus* (n=10), which were collected supplementarily in June from Lake Raduńskie Dolne, the release of glochidia was observed immediately.

### ***Description of the parameters determining the rate of infection in fish***

The following indices were applied to describe the level of parasite infection:

**prevalence** – expressed as the percentage of hosts infected with a given species of parasite of all of the hosts examined,

**mean intensity** – the mean number of parasites per infected host,

**range of intensity** – the limits of intensity determined by the smallest and the largest numbers of parasites in the studied infrapopulation,

**abundance** – the mean number of parasites per host within a sample examined (the total number of parasites collected divided by the number of hosts examined),

**frequency** – percentage contribution of individual species and higher taxa of communities (Pojmańska 1993b, Złotorzycka et al. 1998).

The prevalence index was used to classify the species: dominant (confirmed in more than 50% of the fish examined from a given basin); common (confirmed in 10.1-50% of the fish); rare (confirmed in 4-10% of the fish); sporadic (confirmed in fewer than 4% of the fish) (Pojmańska 1993b, Dzika et al. 2007, Sobecka and Słomińska 2007). With regard to common species, the usual value presented by other authors is “10-50%”, while in the present paper this is given more precisely as “10.1%-50%”.

Host specificity was expressed with the following three categories. The first one (polyxenic parasites) comprised parasites that occurred at specific developmental stages in different, even unrelated, host species. The next category of parasites (oligoxenic parasites) occurred in only a few species, which were not necessarily closely related. The last category of (monoxenic) parasites was recorded in one host (Złotorzycka et al. 1998). It should also be noted that the range of parasite host specificity was determined only for species (this refers to all the fish studied from both lakes).

### ***Description of the identified parasite communities***

In parasitology, a community refers to the assemblage of parasites occurring within a given ecosystem, which can be considered to include the host, its organs and the host's surrounding natural environment.



Thus, the following groups were identified based on strategies for colonization of a new territory:

**allogenic species** – these are species that spend part of their developmental cycles in the aquatic environment, and part in the terrestrial environment. Such species can be easily transported to other basins due to the mobility of their intermediate hosts (i.e. insects in which the parasite larvae develop) or the definitive host (i.e. birds that distribute eggs of parasites). In this instance, fish play the role of the intermediate hosts, while birds and mammals are the definitive hosts.

**autogenic species** – these are parasite species whose entire life cycle occurs within a single environment (aquatic or terrestrial). Such species can colonize a new territory only through natural migration of the host or by introduction by humans. In this instance, fish play the role of either intermediate or definitive hosts (Pojmańska 1993b; Złotorzycka et al. 1998).

The following categories of parasites were determined based on the location of the parasite on or in the host:

**ectoparasites** – these parasites occur on the exterior of the host or in (oral or gill) cavities, and they communicate directly with the surrounding environment. In the present study, glochidia were classified as ectoparasites as they are considered in the majority of studies. However, in some studies they are recognized as endoparasites since they are enclosed in host tissues (Kearn 2004),

**endoparasites** – these parasites occur inside the host.

Based on the parasite developmental stage, the following categories were identified:

**larvae** – this developmental stage occurred after hatching and before reaching the maturity,

**adults** – developmentally/sexually mature. The juvenile tapeworms of the genus *Proteocephalus* found in the European perch are classified as an adult stage.

Another group of parasites included species whose development depends on particular groups of intermediate/paratenic hosts such as mollusks, crustaceans, or other groups of invertebrates (annelids, myriapods, and insects).

Correlations among infection parameters (prevalence and mean intensity) and fish length were analyzed using Pearson product moment correlation coefficient; in turn, seasonal changes in prevalence and intensity (counted together for the two lakes) of infection of fish were analyzed with chi-square test and general linear mixed model.

### ***Parameters used to describe different communities of parasites***

The quantitative and qualitative structures of the parasite communities were described using the following ecological indices:

**Species richness** - this index describes the number of species or higher taxonomic units that form a community.

**Shannon-Wiener diversity index (H)** - this is the most commonly applied index of biological diversity. It is used as a measure of species diversity within communities which have not yet been fully investigated, such as communities of parasites. A value of this index describes the probability of the correct prediction about a species represented by the next individual in a studied sample. The index takes into consideration the number of species and their abundance, which reflects the relations between individual species in a given community. The increasing values of this index indicate the increasing diversity. The index increases with the number of species and as the contribution of various species in a sample equalizes. It is sensitive to changes in the abundance of rare species (Krebs 1994, Magurran 2004). This index has been applied in other studies on parasites, including those by Kennedy (1997), Byrne et al. (2000), Dzika (2003), and Guillen-Hernandez and Whitfield (2004).

$$H = -\sum p_i \ln p_i$$

H - index of species diversity

$p_i$  - proportion of individuals found in the  $i^{\text{th}}$  species „i”:  $p_i = \frac{n_i}{N}$

$n_i$  - number of individuals of one species in samples

N – the total number of individuals in samples

**Pielou index of evenness (J')** - this index describes the evenness (species compensation) in the contribution of individual species. The index assumes values from 0 to 1, and the higher the evenness the closer to unity are the values (Magurran 2004). The quantity J' is also referred to as homogeneity or relative diversity (Zar 1984).

$$J' = \frac{H'}{H_{\max}} = \frac{H'}{\ln S}$$

$H'$  - Shannon-Wiener index

$H_{\max}$  – all species equally abundant,  $\ln S$

S – number of species

**Berger-Parker dominance index (D)** - it indicates the contribution of the most abundant species in a community. The higher the value (closer to 1) of the dominance index the lower the diversity of a community. With values close to zero, the diversity of a community is as high as possible. Often the inverse of the index  $1/D$  is used, because then the index increases along with the diversity and decreases with the species dominance (Magurran 2004). The index has been used in studies on parasites (e.g. Kennedy 1997, Kennedy et al. 1998, Byrne et al. 2000, Dzika 2003, Guillen-Hernandez and Whitfield 2004).

$$D = \frac{N_{\max}}{N}$$

$N_{\max}$  – the number of individuals for the most abundant species  
 $N$  – the number of individuals of all species

**Jaccard faunistic similarity coefficient (Cj)** - this index is applied in comparative qualitative studies of the similarity between groups. In the current study, the index was used to determine the similarity between hosts from different and within same basins. When the index assumes the value of “1” then there is a total similarity (species are identical), and when it assumes the value of “0” then there is a total lack of similarity (a lack of common species). The higher the value of the index, the more species are common to both groups, and the lower it is the more species occur in only one group (Magurran 1988). This index has been used in other studies on parasites (e.g. Salgado-Maldonado and Kennedy 1997, Landsberg et al. 1998, Mladineo 2005, Sobecka and Słomińska 2007).

$$Cj = \frac{j}{a + b - j}$$

$j$  – the number of species common to both sites  
 $a$  – the number of species at site a  
 $b$  – the number of species at site b

**Steinhaus similarity coefficient (S)** - this index is applied in comparative quantitative studies of different assemblages, while also taking into consideration the minimal abundance of each species (Legendre and Legendre 2003). In the present study the index was used to describe similarities between the hosts from different and within same basins. The index assumes values from 0 to 1, with zero indicating a total lack of

similarity. This index is used in studies on parasites (Šimková et al. 2003, Ondračková et al. 2004).

$$S = \frac{2W}{(A + B)}$$

W – sum of the minimum abundance values of various species (i.e. parasite species with the minimum abundance on each host in one population)

A, B – sums of the abundance values of all species in host individuals of one population

The condition of the fish was determined with the Fulton (F) formula (Moyle and Cech 1988).

$$F = \frac{W \times 100}{L^3}$$

W- fish weight (g)

L- the total fish length (cm)

## RESULTS

### *Taxonomic overview of the collected parasites*

The dissections of the fish sampled confirmed 51 species of parasites among the European perch and roach, and digeneans *Diplostomum*, nematodes *Contracaecum*, nematomorphs *Gordionus*, and *Unio* glochidia identified to the genus level. One taxon of digenean and one nematode were not identified for the technical reason, as they were not alive. Juvenile tapeworms of the genus *Proteocephalus* were not identified to the species level either, because their reproductive systems were not fully developed.

#### 1. Monogenea

##### *Dactylogyrus crucifer* Wagener, 1857

This monogenean was recorded on the gills of roach in both lakes, but a higher rate of infection was noted on the fish from Lake Żarnowieckie (Tables 3, 4).

Most of the parasites were located on the gill filaments of the second gill arch (39.2%), then the second one and the third one (28.6%), first one (20.9%), and the least on the fourth one (11.4%).

A correlation was found between the parasite occurrence and the season of the year. The highest values of prevalence and intensity were recorded mainly in the spring ( $p < 0.0001$ ) (Figs 2, 3).

**Table 3**

List of parasites in roach from Lake Żarnowieckie according to basic infection parameters.

Parasite	Number of parasites	Prevalence [%]	Mean intensity	Range of intensity	Abundance	Frequency
<i>Dactylogyrus crucifer</i>	521	24.9	6.9	1-7	1.7	5.7
<i>Dactylogyrus fallax</i>	1	0.3	1.0	1	0.003	0.01
<i>Dactylogyrus nanus</i>	8	1.3	2.0	1-2	0.03	0.1
<i>Dactylogyrus similis</i>	9	3.0	1.0	1	0.03	0.1
<i>Dactylogyrus sphyrna</i>	15	1.3	3.8	2-3	0.05	0.2
<i>Dactylogyrus wunderi</i>	2	0.3	2.0	2	0.007	0.02
<i>Diplozoon paradoxum</i>	9	2.6	1.1	1-2	0.03	0.1
<i>Paradiplozoon homoion homoion</i>	7	2.3	1.0	1	0.02	0.1
<i>Bucephalus polymorphus</i> , met.	27	6.9	1.3	1-2	0.1	0.3
<i>Diplostomum gavium</i> , met.	88	4.3	6.8	1-55	0.3	1.0
<i>Diplostomum</i> spp., met.	3476	94.7	12.0	3-55	11.4	37.9
<i>Ichthyocotylurus platycephalus</i> , met.	6	1.0	2.0	1-2	0.02	0.1
<i>Posthodiplostomum cuticola</i> , met.	205	13.4	5.0	1-28	0.7	2.2
<i>Sphaerostomum bramae</i>	32	1.0	10.7	4-20	0.1	0.3
<i>Tylodelphys clavata</i> , met.	4432	79.3	18.3	1-79	14.5	48.3
<i>Caryophyllaeides fennica</i>	22	3.9	1.8	1-3	0.1	0.2
<i>Paradilepis scolecina</i> , pl.	123	24.6	1.6	1-15	0.4	1.3
<i>Desmidocerella numidica</i> , L3	12	0.7	6.0	3-9	0.04	0.1
<i>Raphidascaris acus</i> , L3	16	3.6	1.5	1-3	0.1	0.2
Nematoda, n.det., L3*	7	1.0	2.3	2-3	0.02	0.1
<i>Ergasilus sieboldi</i>	45	3.0	5.0	2-8	0.1	0.5
<i>Argulus foliaceus</i>	23	6.2	1.2	1-3	0.1	0.3
<i>Caspiobdella fadejevi</i>	3	0.7	1.5	1-2	0.01	0.03
<i>Piscicola geometra</i>	47	10.5	1.5	1-5	0.2	0.5
<i>Anodonta anatina</i> , gl.	58	13.8	1.4	1-7	0.2	0.6
Total	9194	95.1	31.7	1-115	30.1	100.0

gl.: glochidium, L3: the third stage larva, met.: metacercaria, pl.: plerocercus, \*: dead specimens

In Lake Żarnowieckie parasites were recorded mainly on fish longer than 21.1 cm ( $p < 0.01$  for prevalence) and in Lake Raduńskie Dolne – on fish longer than 18.1 cm (Figs 4, 5).

The level of parasitic infection of females and males in Lake Żarnowieckie was 24.3% (prevalence) and 9.3 (mean intensity), and 25.8%, 3.7, respectively, while in Lake Raduńskie Dolne it was 17.2%, 6.2 and 24.6%, 7.0, respectively.

#### *Dactylogyrus fallax* Wagener, 1857

This monogenean was recorded in Lake Żarnowieckie on one roach (♀, 22.5 cm long) (Table 3) on the gill filaments of the second gill arch and only in summer.

#### *Dactylogyrus nanus* Dogiel et Bychovsky, 1934

This parasite was recorded in Lake Żarnowieckie in four specimens of roach (3 ♀♀, 18.1-27.0 cm long, 1 ♂, 16.4 cm long) and in Lake Raduńskie Dolne in

**Table 4**

List of parasites in roach from Lake Raduńskie Dolne according to basic infection parameters.

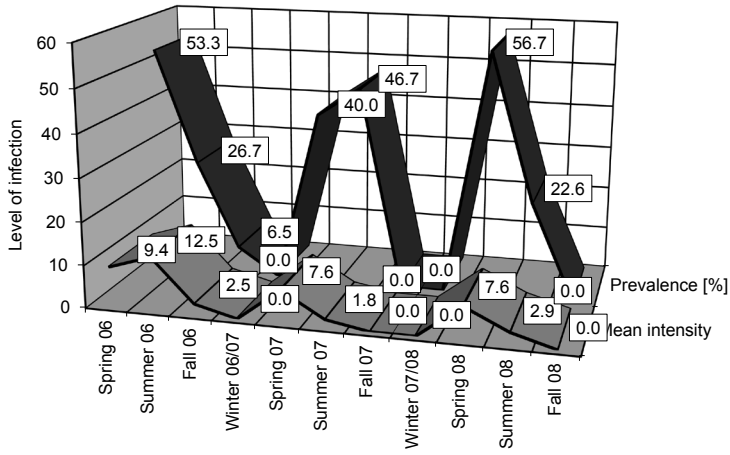
Parasite	Number of parasites	Prevalence [%]	Mean intensity	Range of intensity	Abundance	Frequency [%]
<i>Dactylogyrus crucifer</i>	412	20.5	6.6	1-8	1.4	2.9
<i>Dactylogyrus nanus</i>	8	2.0	1.3	1-2	0.03	0.1
<i>Dactylogyrus similis</i>	23	6.3	1.2	1-4	0.08	0.2
<i>Diplozoon paradoxum</i>	14	4.3	1.1	1-2	0.05	0.1
<i>Paradiplozoon homoion homoion</i>	3	0.7	1.5	1-2	0.01	0.02
<i>Bucephalus polymorphus</i> , met.	1032	4.0	86.0	1-311	3.4	7.3
<i>Diplostomum gavium</i> , met.	1956	11.2	57.5	1-105	6.5	13.8
<i>Diplostomum</i> spp., met.	4005	100.0	13.2	1-294	13.2	28.3
<i>Ichthyocotylurus platycephalus</i> , met.	37	2.0	6.2	1-8	0.1	0.3
<i>Ichthyocotylurus pileatus</i> , met.	12	3.0	1.3	1-3	0.04	0.1
<i>Paleorchis incognitus</i>	8	1.7	1.6	1-3	0.03	0.1
<i>Paracoenogonimus ovatus</i> , met.	408	4.0	34.0	2-118	1.3	2.9
<i>Posthodiplostomum cuticola</i> , met.	526	24.8	7.0	1-56	1.7	3.7
<i>Rhipidocotyle campanula</i> , met.	67	14.2	1.6	1-15	0.2	0.5
<i>Sphaerostomum bramae</i>	12	3.0	1.3	1-2	0.04	0.1
<i>Sphaerostomum globiporum</i>	28	6.0	1.6	1-4	0.09	0.2
<i>Tylodelphys clavata</i> , met.	5111	83.2	20.3	4-246	16.9	36.2
Digenea, n.det., met.*	77	1.7	15.4	1-68	0.3	0.5
<i>Caryophyllaeides fennica</i>	33	4.0	2.8	1-8	0.1	0.2
<i>Caryophylleus laticeps</i>	5	1.0	1.7	1-2	0.02	0.04
<i>Paradilepis scolecina</i> , pl.	119	16.2	2.4	1-11	0.4	0.8
<i>Philometra ovata</i>	3	1.0	1.0	1	0.01	0.02
<i>Raphidascaris acus</i> , L3	36	4.0	3.0	1-5	0.1	0.3
<i>Acanthocephalus lucii</i>	6	1.3	1.5	1-2	0.02	0.04
<i>Caligus lacustris</i>	3	1.0	1.0	1	0.01	0.02
<i>Ergasilus briani</i>	42	5.6	2.5	1-4	0.1	0.3
<i>Ergasilus sieboldi</i>	39	5.0	2.6	1-4	0.1	0.3
<i>Argulus foliaceus</i>	65	9.0	2.4	1-8	0.2	0.5
<i>Piscicola geometra</i>	21	5.3	1.3	1-4	0.07	0.1
<i>Anodonta anatina</i> , gl.	18	2.6	2.3	1-3	0.06	0.1
Total	14129	100.0	46.6	1-374	46.6	100.0

gl.: glochidium, L3: the third stage larva, met.: metacercaria, pl.: plerocercus, \*: dead specimens

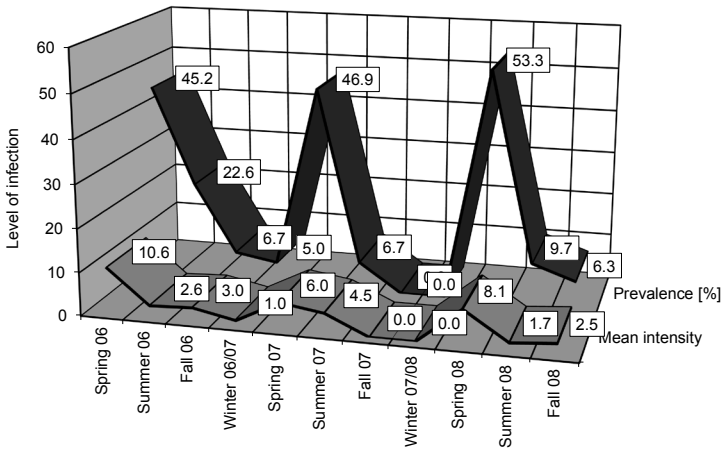
six fishes (3 ♀♀, 22.3-23.4 cm long, 3 ♂♂, 24.1-26.3 cm long) (Tables 3, 4). It was noted on the gill filaments of the second (6 specimens) and the fourth (10 specimens) gill arches during the spring.

### *Dactylogyrus similis* Wegener, 1909

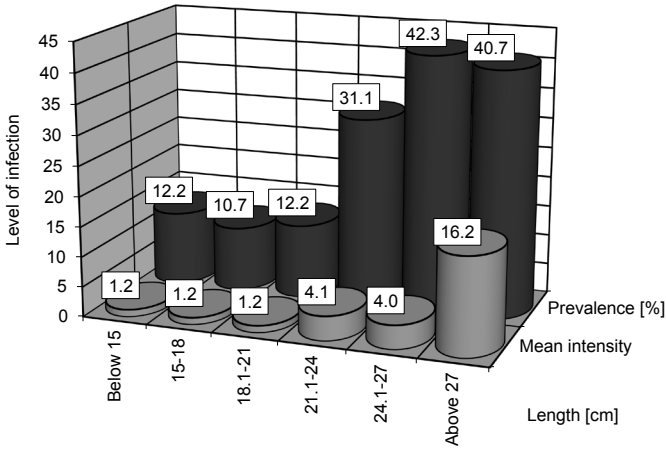
This monogenean was noted on the gills of roach from both lakes. A higher level of infection was noted in the fish from Lake Raduńskie Dolne (Tables 3, 4). Only female roach from Lake Żarnowieckie (15-19.2 cm in length) were infected with parasites, while infection in fish from Lake Raduńskie Dolne was confirmed on 15 females (12.2-24.5 cm in length) and four males (25.1-26.3 cm in length). Parasites were recorded on the filaments of the fourth (65.3%) and the third (34.7%) gill arches. They were collected in



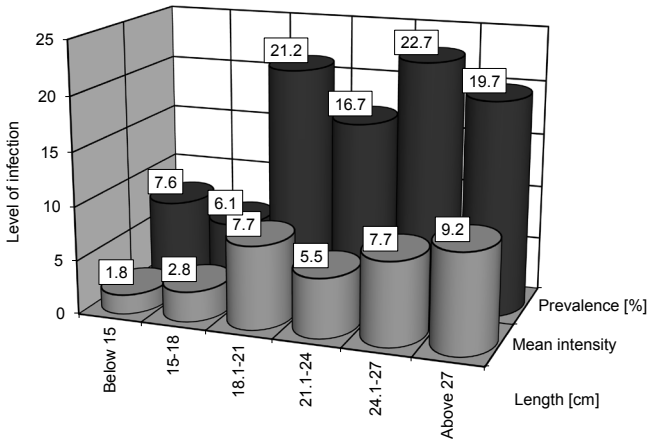
**Fig. 2.** Seasonal occurrence of *Dactylogyrus crucifer* in roach from Lake Żarnowieckie.



**Fig. 3.** Seasonal occurrence of *Dactylogyrus crucifer* in roach from Lake Raduńskie Dolne.



**Fig. 4.** Correlation between the occurrence of *Dactylogyrus crucifer* and the roach length in Lake Żarnowieckie.



**Fig. 5.** Correlation between the occurrence of *Dactylogyrus crucifer* and the roach length in Lake Raduńskie Dolne.



spring (7 specimens in Lake Żarnowieckie and 10 in Lake Raduńskie Dolne) and in summer (2 and 13 specimens respectively).

*Dactylogyrus sphyrna* Linstow, 1878

This parasite was confirmed only on four specimens of roach (3 ♀♀, 18.5-24.1 cm long, 1 ♂, 17.4 cm long) from Lake Żarnowieckie (Table 3). The parasites were collected from the gill filaments of the first (6 specimens), the second (6 specimens) and the third (3 specimens) gill arches during the summer period.

*Dactylogyrus wunderi* Bychowski, 1931

This parasite was confirmed on one roach (♀, 11.5 cm long) from Lake Żarnowieckie (Table 3). The parasites were collected from the gill filaments and from the third gill arch during the spring period.

*Diplozoon paradoxum* Nordmann, 1832

This monogenean was recorded on the gills of fish from both lakes, but higher infection parameters were obtained for the fish from Lake Raduńskie Dolne (Tables 3, 4). The parasites were recorded on two females (the length of 22.8, 31.6 cm) and six males (21.9-26.9 cm long) of roach from Lake Żarnowieckie, while in Lake Raduńskie Dolne, they were found on 12 females (22.8-32.1 cm long) and one male (23.6 cm long). The parasites were observed on all gill arches as follows: six parasites on the first gill arch, seven on the second one, six on the third one and four on the fourth one. In Lake Żarnowieckie they were collected during spring (6 specimens) and summer (3 specimens), while in Lake Raduńskie Dolne – in spring (10 specimens) and fall (4 specimens).

*Paradiplozoon homoion homoion* (Bykhovsky et Nagibina, 1959)

This monogenean was found on seven roach specimens (4 ♀♀, 26.9-29.1 cm long, 3 ♂♂, 23.8-25.5 cm long) from Lake Żarnowieckie, and on two fishes (♂♂, 28.0, 28.5 cm long) from Lake Raduńskie Dolne (Table 3, 4). The parasites were collected in summer 2007, and they were located on filaments of the third gill arch.

## 2. Digenea

*Apatemon gracilis* (Rudolphi, 1819), metacercaria

**Table 5**

List of parasites in European perch from Lake Żarnowieckie according to basic infection parameters.

Parasite	Number of parasites	Prevalence [%]	Mean intensity	Range of intensity	Abundance	Frequency [%]
<i>Apatemon gracilis</i> , met.	165	16.3	3.3	1-10	0.5	0.9
<i>Azygia lucii</i>	21	3.9	1.8	1-2	0.07	0.1
<i>Bunodera luciopercae</i>	515	24.8	6.8	1-29	1.7	3.0
<i>Diplostomum</i> spp., met	1593	29.3	17.7	1-142	5.2	9.2
<i>Ichthyocotylurus pileatus</i> , met.	180	8.5	6.9	1-18	0.6	1.0
<i>Ichthyocotylurus platycephalus</i> , met.	54	4.6	3.9	1-8	0.2	0.3
<i>Ichthyocotylurus variegatus</i> , met.	142	6.5	7.1	1-12	0.5	0.8
<i>Tylodelphys clavata</i> , met.	13295	46.3	93.6	1-197	43.3	76.4
<i>Eubothrium crassum</i> , pl.	8	2.0	1.3	1-2	0.03	0.05
<i>Proteocephalus percae</i>	22	6.2	1.2	1-3	0.07	0.1
<i>Triaenophorus nodulosus</i> , pl.	105	10.1	3.4	1-8	0.34	0.6
<i>Anisakis simplex</i> , L3	2	0.3	2.0	2	0.007	0.01
<i>Camallanus lacustris</i>	433	26.4	5.3	1-25	1.4	2.5
<i>Camallanus truncatus</i>	12	2.6	1.5	1-2	0.04	0.1
<i>Acanthocephalus lucii</i>	515	25.4	6.6	1-43	1.7	3.0
<i>Echinorhynchus gadi</i>	2	0.3	2.0	2	0.007	0.01
<i>Pomphorhynchus laevis</i>	2	0.3	2.0	1	0.007	0.01
<i>Achtheres percarum</i> , ch.IV, ad.	201	24.4	2.7	1-8	0.7	1.2
<i>Ergasilus sieboldi</i>	78	3.9	6.5	1-36	0.3	0.4
<i>Argulus foliaceus</i>	18	4.6	1.3	1-3	0.06	0.1
<i>Piscicola geometra</i>	23	6.2	1.2	1-2	0.07	0.1
<i>Anodonta anatina</i> , gl.	9	2.9	1.0	1	0.03	0.1
Total	17395	63.2	89.7	1-201	56.7	100.0

ad.: adult, ch.IV: the fourth chalimus, gl.: glochidium, L3: the third stage larva, met.: metacercaria, pl.: plerocercoid

This digenean was confirmed in the vitreous humor of the European perch from both lakes, with slightly higher infection parameters in the fish from Lake Raduńskie Dolne (Tables 5, 6).

Changes in the level of infection were observed in different seasons of the year. As a rule, the highest infection parameters were obtained for European perch in the fall period (Figs 6, 7) ( $p < 0.001$  for prevalence in both lakes).

Higher infection values were recorded in fish longer than 21.1 cm ( $p < 0.05$  for prevalence in Lake Raduńskie Dolne) (Fig. 8, 9).

The level of infection in female and male European perch from Lake Żarnowieckie was as follows: 16.4%, 3.4 and 16.1%, 3.1, respectively; while in Lake Raduńskie Dolne they were: 20.1%, 4.6 and 14.7%, 3.4, respectively.

### *Azygia lucii* (Müller, 1776)

This digenean was found in 12 specimens of European perch (4 ♀♀, 23.6-27.3 cm long, 8 ♂♂, 22.2-26.4 cm long) from Lake Żarnowieckie and in

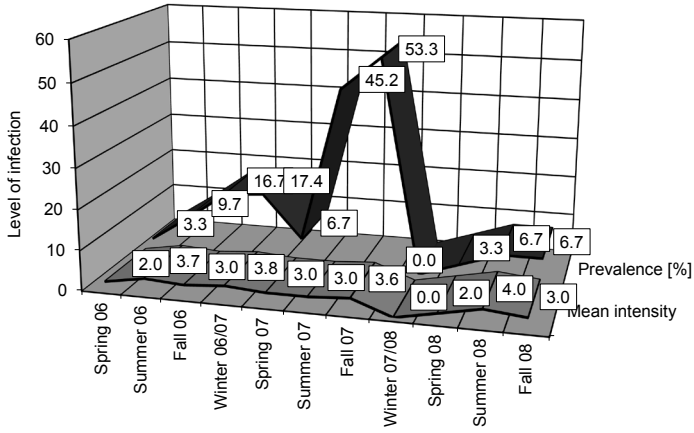
**Table 6**

List of parasites in European perch from Lake Raduńskie Dolne according to basic infection parameters.

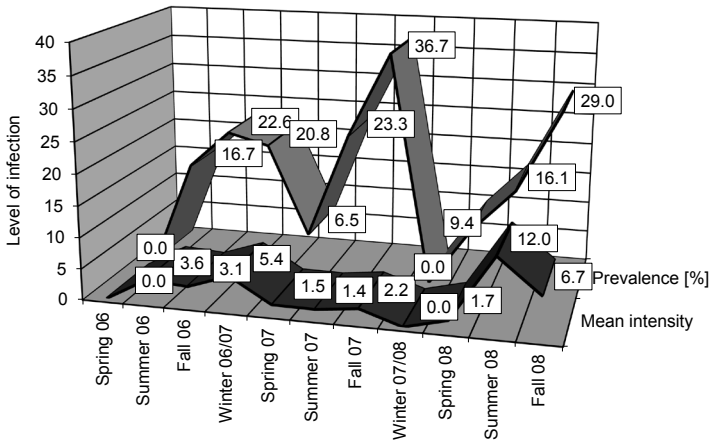
Parasite	Number of parasites	Prevalence [%]	Mean intensity	Range of intensity	Abundance	Frequency [%]
<i>Apatemon gracilis</i> , met.	229	18.0	4.2	1-15	0.8	1.11
<i>Azygia lucii</i>	16	5.3	1.0	1	0.1	0.08
<i>Bunodera luciopercae</i>	806	36.0	7.5	1-23	2.7	3.91
<i>Diplostomum</i> spp., met.	2284	61.7	12.3	1-85	7.6	11.1
<i>Ichthyocotylurus pileatus</i> , met.	367	7.0	17.5	1-25	1.2	1.8
<i>Ichthyocotylurus platycephalus</i> , met.	124	4.7	8.9	1-7	0.4	0.6
<i>Ichthyocotylurus variegatus</i> , met.	240	14.3	5.6	1-28	0.8	1.2
<i>Phyllodistomum folium</i>	14	2.7	1.8	2-3	0.05	0.07
<i>Rhipidocotyle campanula</i> , met.	29	2.3	4.1	2-9	0.1	0.1
<i>Rhipidocotyle campanula</i> , ad.	26	6.0	1.4	1-5	0.1	0.1
<i>Tylodelphys clavata</i> , met.	12702	80.7	52.5	1-363	42.3	61.6
<i>Proteocephalus percae</i>	89	10.3	2.9	1-8	0.3	0.4
<i>Proteocephalus</i> spp.*	2	0.3	2.0	2	0.01	0.01
<i>Trienophorus nodulosus</i> , pl.	341	18.7	6.1	1-15	1.1	1.7
<i>Anguillicoloides crassus</i> , L3	8	2.7	1.0	1	0.03	0.04
<i>Camallanus lacustris</i>	1741	44.0	13.2	1-36	5.8	8.4
<i>Contracaecum</i> sp., L3	2	0.7	1.0	1	0.01	0.01
<i>Cosmocephalus obvelatus</i> , L3	8	2.3	1.1	1-2	0.03	0.04
<i>Desmidocercella numidica</i> , L3	4	0.7	2.0	1-3	0.01	0.02
<i>Eustrongylides excisus</i> , L4	24	2.3	3.4	2-4	0.1	0.1
<i>Acanthocephalus lucii</i>	1284	37.7	11.4	1-20	4.3	6.2
<i>Gordionus</i> sp.	1	0.3	1.0	1	0.003	0.005
<i>Achtheres percarum</i> , ch.IV, ad.	112	21.7	1.7	1-5	0.4	0.5
<i>Ergasilus sieboldi</i>	48	4.7	3.4	1-8	0.2	0.2
<i>Argulus foliaceus</i>	33	5.7	1.9	1-4	0.1	0.2
<i>Piscicola geometra</i>	18	5.7	1.1	1-2	0.1	0.09
<i>Anodonta anatina</i> , gl.	23	4.3	1.8	1-4	0.1	0.1
<i>Pseudanodonta complanata</i> , gl.	8	2.3	1.1	1-2	0.03	0.04
<i>Unio</i> sp., gl.	43	7.7	1.9	1-9	0.1	0.2
Total	20626	85.7	80.3	1-394	68.8	100.0

ad.: adult, ch.IV: the fourth chalmus, gl.: glochidium, L3, 4: the third/fourth stage larva, met.: metacercaria, pl.: plerocercoid, \*: juvenile specimens

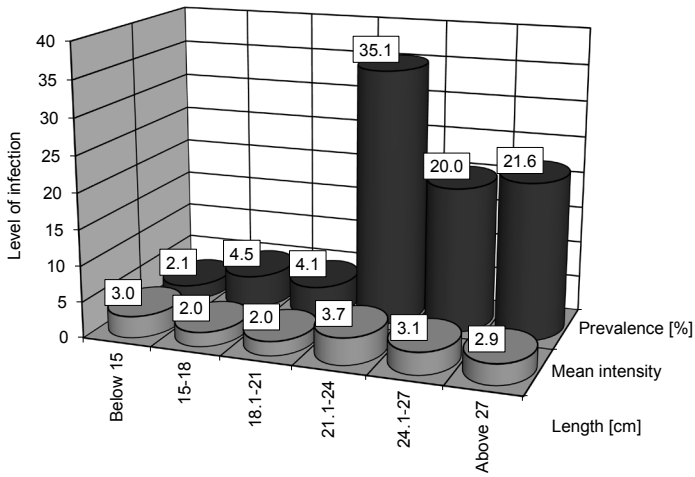
16 fishes (10 ♀♀, 19,6-24.9 cm long, 6 ♂♂, 21.8-28.7 cm long) from Lake Raduńskie Dolne (Table 5, 6). They were observed in summer (2 specimens) and fall (19 specimens) in Lake Żarnowieckie, while in Lake Raduńskie Dolne – in spring (3 specimens), summer (6 specimens) and fall (7 specimens). With the exception of one specimen (fall 2007, Lake Żarnowieckie), eggs were found in the uteruses of the collected digeneans. Most of the digeneans were found in the stomach, but eight parasites were found in the oral cavity and one in the gill cavity. This atypical location of *A. lucii* is linked to parasites' reaction to the death of the fish, which prompts them to leave the host stomach.



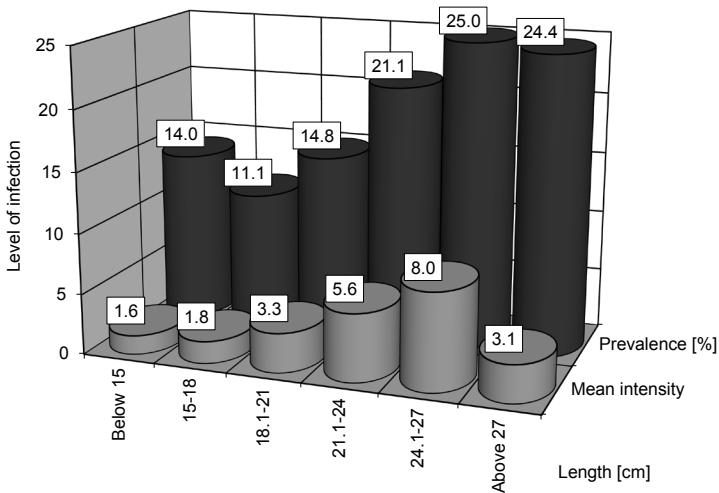
**Fig. 6.** Seasonal occurrence of *Apatemon gracilis* in European perch from Lake Żarnowieckie.



**Fig. 7.** Seasonal occurrence of *Apatemon gracilis* in European perch from Lake Raduńskie Dolne.



**Fig. 8.** Correlation between the occurrence of *Apatemon gracilis* and the European perch length in Lake Żarnowieckie.



**Fig. 9.** Correlation between the occurrence of *Apatemon gracilis* and the European perch length in Lake Raduńskie Dolne.

*Bucephalus polymorphus* Baer, 1827, metacercaria

Metacercariae were confirmed on 21 roach specimens (11 ♀♀, 13.7-29.9 cm long, 10 ♂♂, 17.8-29.5 cm long) from Lake Żarnowieckie and 12 fishes (8 ♀♀, 14.6-18.4 cm long, 4 ♂♂, 12.0-14.3 cm long) from Lake Raduńskie Dolne (Tables 3, 4).

The parasites were found on the rays and in the spaces between the rays of the pelvic (46.1%), pectoral (31.0%) and tail (22.9%) fins.

In Lake Żarnowieckie they were collected in the summer (7 specimens), the fall (3) and the winter (17), while in Lake Raduńskie Dolne – in the summer (10 specimens) and the fall (1022).

*Bunodera luciopercae* (Müller, 1776)

These parasites occurred in European perch from both lakes, but the fish from Lake Raduńskie Dolne have higher rates of infection (Tables 5, 6).

In Lake Żarnowieckie these digeneans were recorded most frequently in spring and fall, while in Lake Raduńskie Dolne during the summer and fall ( $p < 0.001$  for prevalence and  $p < 0.05$  for mean intensity for both lakes) (Fig. 10, 11). In the periods when these parasites were recorded, in addition to adult specimens, juveniles (i.e. specimens lacking eggs in uteruses) were also found.

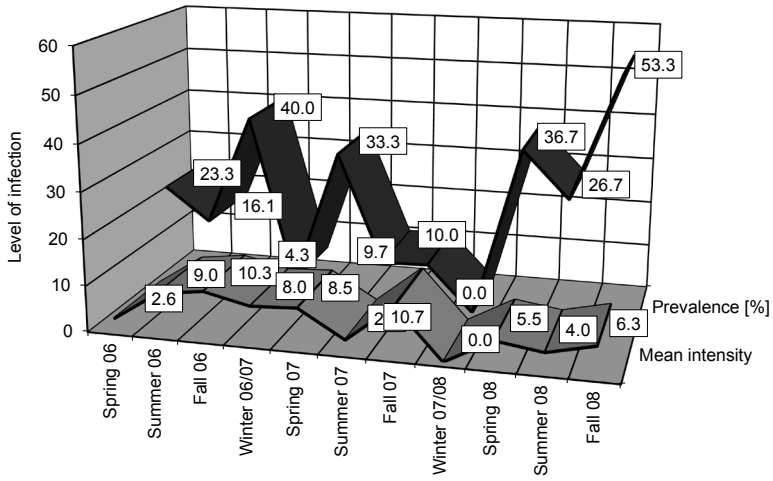
Among the collected 1321 digeneans, more than half (58.8%) were juvenile specimens. They were found only in the pyloric caeca, while adult specimens were found in the intestine (134 specimens) and pyloric caeca (410 specimens). Additionally, in cases when *B. luciopercae* was found in the pyloric caeca, the number of other parasites (especially nematodes of the genus *Camallanus*) decreased. However, with the abundance exceeding five adult nematodes, digeneans were not found.

The highest infection parameters of European perch from Lake Żarnowieckie were recorded for fishes in the length range of 24.1-27 cm, while in Lake Raduńskie Dolne – for fishes of 18.1-21 cm in length (for prevalence) and in those of 15-18 cm in length (for mean intensity) (Figs 12, 13).

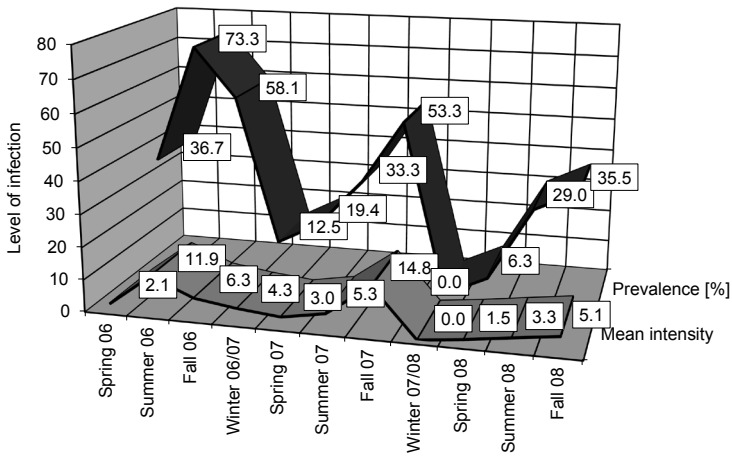
The level of infection in females and males of European perch from Lake Żarnowieckie was: prevalence 30.3%, mean intensity 7.3 and 15.2%, 5.1, respectively, while in Lake Raduńskie Dolne: 48.4%, 8.4 and 16.4%, 2.8, respectively.

*Diplostomum gavium* (Guberlet, 1922), metacercaria

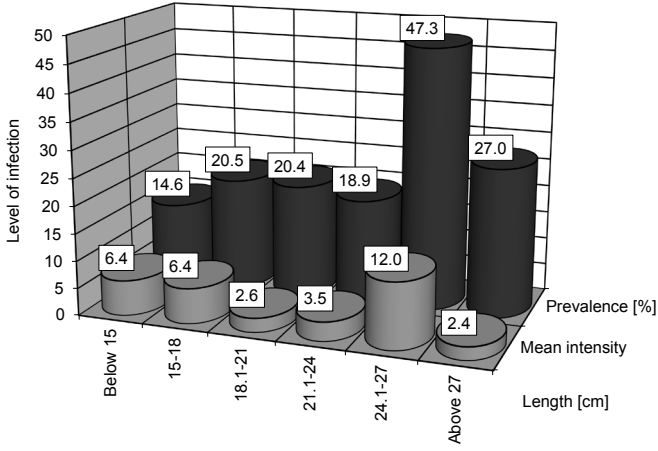
Metacercaria of this species were found in the vitreous humor of roach from both lakes, with higher infection parameters in fish from Lake Raduńskie Dolne (Tables 3, 4).



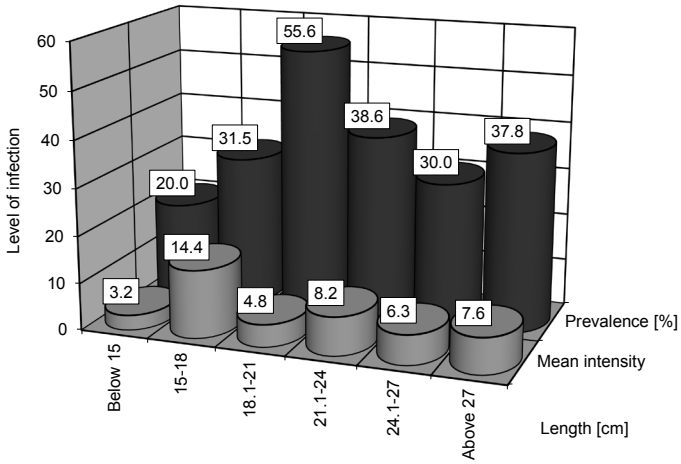
**Fig. 10.** Seasonal occurrence of *Bunodera luciopercae* in European perch from Lake Żarnowieckie.



**Fig. 11.** Seasonal occurrence of *Bunodera luciopercae* in European perch from Lake Raduńskie Dolne.

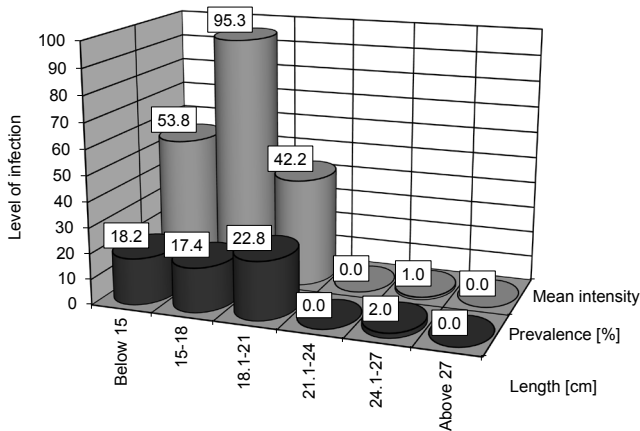


**Fig. 12.** Correlation between the occurrence of *Bunodera luciopercae* and the European perch length in Lake Żarnowieckie.



**Fig. 13.** Correlation between the occurrence of *Bunodera luciopercae* and the European perch length in Lake Raduńskie Dolne.





**Fig. 14.** Correlation between the occurrence of *Diplostomum gavium* and the roach length in Lake Raduńskie Dolne.

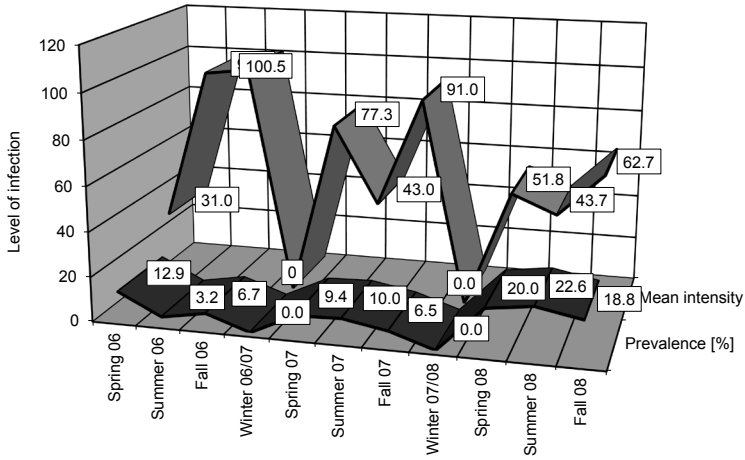
The parasites were found mainly in smaller fish less than 21.1 cm long. Only two specimens of *D. gavium* were found in one fish measuring 24.5 cm (Fig. 14).

The prevalence of this parasite in Lake Raduńskie Dolne during the studied seasons of 2007 and 2008 was at the maximum in summer, while in the study season of 2006, it was the highest in spring. In turn, the intensity was the highest in fall (Fig. 15). *D. gavium* was noted in Lake Żarnowieckie in spring (15 specimens), summer (22), fall (32) and winter (19).

The level of infection in roach females and males from Lake Raduńskie Dolne was: prevalence 10.7%, mean intensity 68.7 and 11.9%, 45.0, respectively. However, the infected roach from Lake Żarnowieckie included nine females (12.9-20.9 cm long) and four males (16.7-20.8 cm long).

When the occurrence of *D. gavium* was recorded in vitreous humor, there was either a decline or the total absence of other metacercariae of the genus *Diplostomum* and *Tylodelphys clavata*. With the intensity exceeding 10.0 parasites in an eye, there was heavy hemorrhaging in the vitreous humor, something that is never observed with other *Diplostomum* spp. or *T. clavata*.

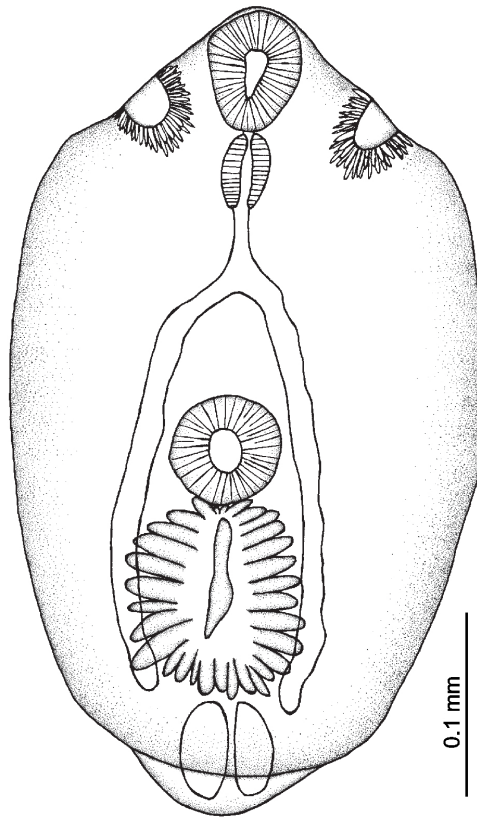
Since *D. gavium* metacercariae were found in roach for the first time from Poland, their measurements are presented (n=30 for Lake Żarnowieckie, n= 30 for Lake Raduńskie Dolne, in mm). Excretory bodies were counted in live specimens. Measurements were performed on total preparations.



**Fig. 15.** Seasonal occurrence of *Diplostomum gavium* in roach from Lake Raduńskie Dolne.

Description (Fig. 16):

The anterior end of the body is pointed and distinctly separated from the rest of the body, while the posterior segment is conical with a broad base. The maximum lengths and widths of the metacercaria bodies collected and measured from Lakes Żarnowieckie and Raduńskie Dolne  $0.394\text{-}0.423 \times 0.248\text{-}0.270$  (mean  $0.411 \times 0.254$ ,  $\pm\text{SD } 0.013 \times 0.013$ ),  $0.396\text{-}0.412 \times 0.249\text{-}0.264$  (mean  $0.403 \times 0.257$ ,  $\pm\text{SD } 0.007 \times 0.006$ ) respectively; oral sucker  $0.055\text{-}0.062 \times 0.041\text{-}0.047$  (mean  $0.059 \times 0.044$ ,  $\pm\text{SD } 0.003 \times 0.003$ ),  $0.056\text{-}0.059 \times 0.042\text{-}0.047$  (mean  $0.057 \times 0.044$ ,  $\pm\text{SD } 0.001 \times 0.002$ ); prepharynx was very short or not present at  $0.0039\text{-}0.0059$  (mean  $0.0049$ ,  $\pm\text{SD } 0.0008$ ),  $0.0039\text{-}0.0058$  (mean  $0.005$ ,  $\pm\text{SD } 0.0007$ ); pharynx  $0.043\text{-}0.047 \times 0.016\text{-}0.019$  (mean  $0.045 \times 0.017$ ,  $\pm\text{SD } 0.002 \times 0.001$ ),  $0.042\text{-}0.045 \times 0.016\text{-}0.018$  (mean  $0.044 \times 0.017$ ,  $\pm\text{SD } 0.001 \times 0.001$ ); acetabulum  $0.047\text{-}0.059 \times 0.055\text{-}0.064$  (mean  $0.053 \times 0.060$ ,  $\pm\text{SD } 0.005 \times 0.004$ ),  $0.047\text{-}0.057 \times 0.054\text{-}0.062$  (mean  $0.053 \times 0.058$ ,  $\pm\text{SD } 0.003 \times 0.003$ ); the holdfast organ was large, oval and deeply cleaved  $0.101\text{-}0.109 \times 0.089\text{-}0.101$  (mean  $0.105 \times 0.096$ ,  $\pm\text{SD } 0.003 \times 0.006$ ),  $0.102\text{-}0.107 \times 0.093\text{-}0.099$  (mean  $0.105 \times 0.097$ ,  $\pm\text{SD } 0.002 \times 0.002$ ); distance between the acetabulum centre and the anterior extremity of the body  $0.211\text{-}0.242$  (mean  $0.226$ ,  $\pm\text{SD } 0.012$ ),  $0.206\text{-}0.232$  (mean  $0.223$ ,  $\pm\text{SD } 0.01$ ); cup-shaped pseudosuckers are located halfway or almost halfway along the length of the



**Fig. 16.** *Diplostomum gavium*, met. from vitreous humor of roach.

oral sucker; the body width at the pseudosuckers – 0.079-0.089 (mean 0.084,  $\pm$ SD 0.004), 0.081-0.087 (mean 0.084,  $\pm$ SD 0.002); the body width at the level of the oral sucker 0.073-0.077 (mean 0.076,  $\pm$ SD 0.002), 0.073-0.076 (mean 0.075,  $\pm$ SD 0.001); the body width at the level of the intestine bifurcation 0.230-0.253 (mean 0.245,  $\pm$ SD 0.009), 0.228-0.261 (mean 0.248,  $\pm$ SD 0.013); the length of the lappet 0.047-0.070 (mean 0.06,  $\pm$ SD 0.01), 0.042-0.058 (mean 0.05,  $\pm$ SD 0.006). The number of excretory bodies 302-425, (mean 383,  $\pm$ SD 46), 345-387 (mean 369,  $\pm$ SD 13). They were distributed in three elongated fields. Indices: width/length of the body (%): 58.9-63.8 (mean 61.7,  $\pm$ SD 19.0), 62.9-64.1 (mean 63.7,  $\pm$ SD 0.8); length  $\times$  width of the body/length  $\times$  width of the holdfast organ: 10.3-10.9 (mean 10.4,  $\pm$ SD 0.4), 10.1-10.4 (mean 10.2,  $\pm$ SD

0.2); length  $\times$  width of the body/length  $\times$  width of acetabulum: 30.1-37.7 (mean 33.4,  $\pm$ SD 3.9), 30.8-38.8 (mean 33.5,  $\pm$ SD 3.0); length  $\times$  width of oral sucker/length  $\times$  width of acetabulum: 0.77-0.92 (mean 0.83,  $\pm$ SD 0.05), 0.78-0.93 (mean 0.82,  $\pm$ SD 0.06); length  $\times$  width of the holdfast organ/length  $\times$  width of acetabulum: 2.9-3.6 (mean 3.2,  $\pm$ SD 0.3), 2.9-3.7 (mean 3.3,  $\pm$ SD 0.3); length  $\times$  width of oral sucker/length  $\times$  width of pharynx: 3.1-3.5 (mean 3.3,  $\pm$ SD 0.1), 3.4-3.5 (mean 3.4,  $\pm$ SD 0.1); distance between the centre of the acetabulum and the anterior extremity of the body/length of the body (%): 53.6-57.2 (mean 54.9,  $\pm$ SD 1.7), 52.0-56.3 (mean 55.3,  $\pm$ SD 2.0); width of the body at the level of mid-length of the oral sucker/width of the body at the level of intestine bifurcation: 0.30-0.32 (mean 0.31,  $\pm$ SD 0.01), 0.33-0.36 (mean 0.3,  $\pm$ SD 0.01).

#### *Diplostomum* spp., metacercaria

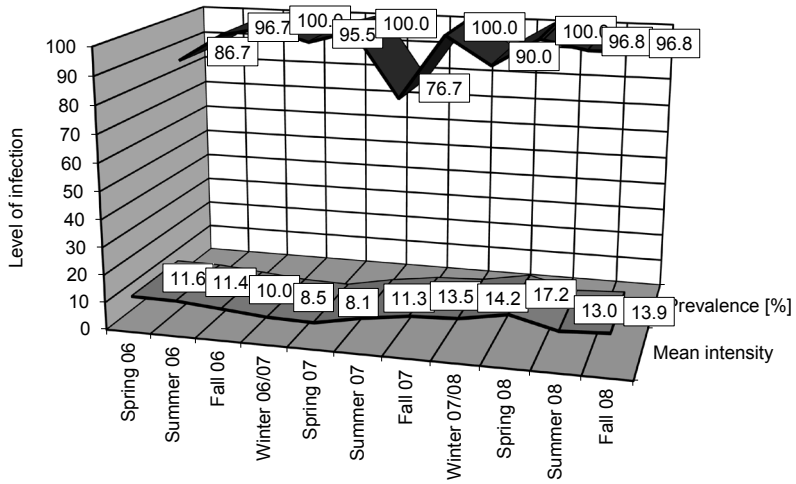
Parasites from this genus included metacercariae collected from fish lenses (3684 parasites from roach and 2169 from European perch from Lake Raduńskie Dolne and 3204 from roach and 1507 from European perch from Lake Żarnowieckie) and some from the vitreous humor (321, 115, 272 and 86 parasites, respectively). Because the morphological structures of most metacercariae of the genus *Diplostomum* are very similar, it is very difficult to classify them down to the species level, which is why the collective genus name is usually used (Niewiadomska 1996).

Metacercariae from eye lenses occurred in larger, common aggregations, and less frequently as single specimens; however, they always occurred as single specimens in the vitreous humor.

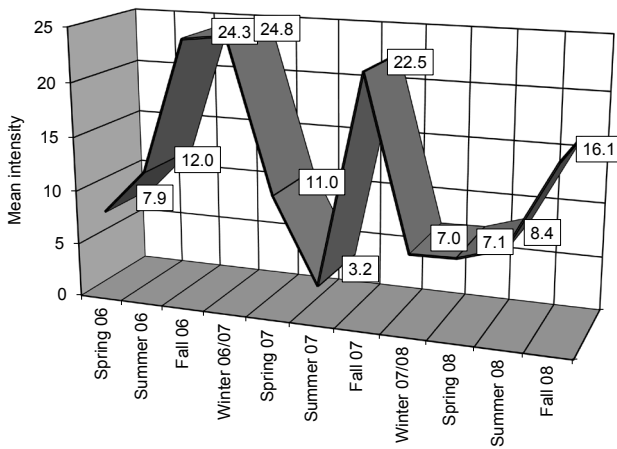
*Diplostomum* spp. were some of the most frequently recorded parasites in the examined fish. Higher prevalence was noted in roach, while the mean intensity was similar in both fish species (Tables 3-6).

These parasites revealed seasonal variation (Figs 17-20), but the prevalence of infection was 100% in the roach from Lake Raduńskie Dolne.

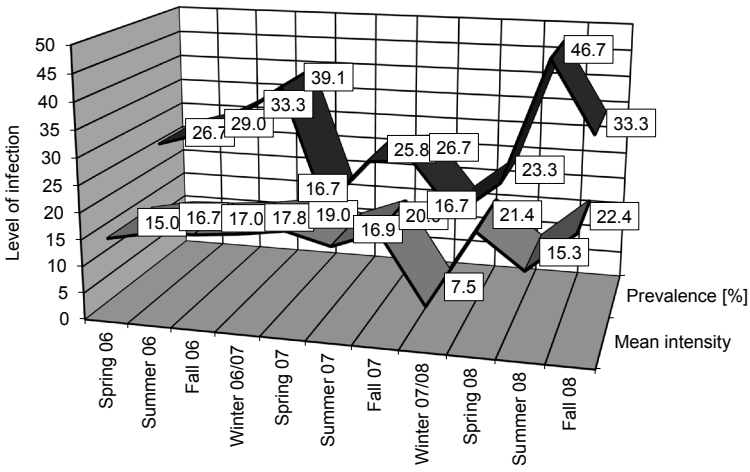
Higher mean intensity of infection was noted in Lake Żarnowieckie among specimens of roach with the length of 21.1-24 cm (Fig. 21), while in Lake Raduńskie Dolne in fish with the length of 18.1-21 cm (Fig. 22). Prevalence in roach from Lake Żarnowieckie was always higher than 87.0%. In European perch from Lake Żarnowieckie, the most strongly infected individuals measured 18.1-21 cm in length (Fig. 23). However, the highest prevalence in European perch from Lake Raduńskie Dolne was recorded in fish measuring 15-18 cm, while the largest mean intensity – in fish with the length of 18.1-21 cm (Fig. 24).



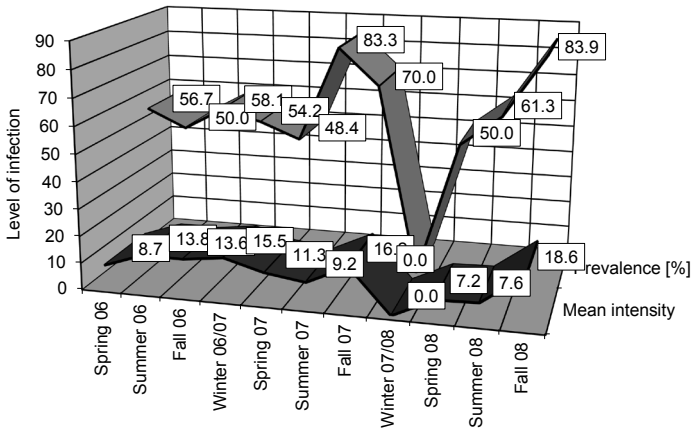
**Fig. 17.** Seasonal occurrence of *Diplostomum* spp. in roach from Lake Żarnowieckie.



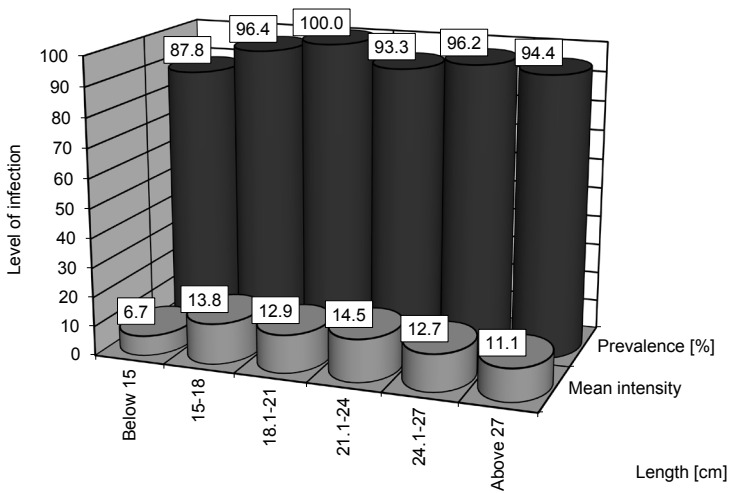
**Fig. 18.** Mean intensity of infection of roach from Lake Raduńskie Dolne with *Diplostomum* spp. in relation to the season.



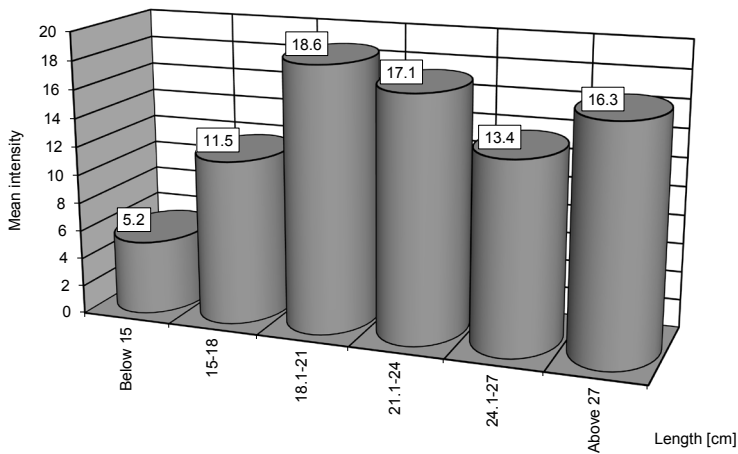
**Fig. 19.** Seasonal occurrence of *Diplostomum* spp. in European perch from Lake Żarnowieckie.



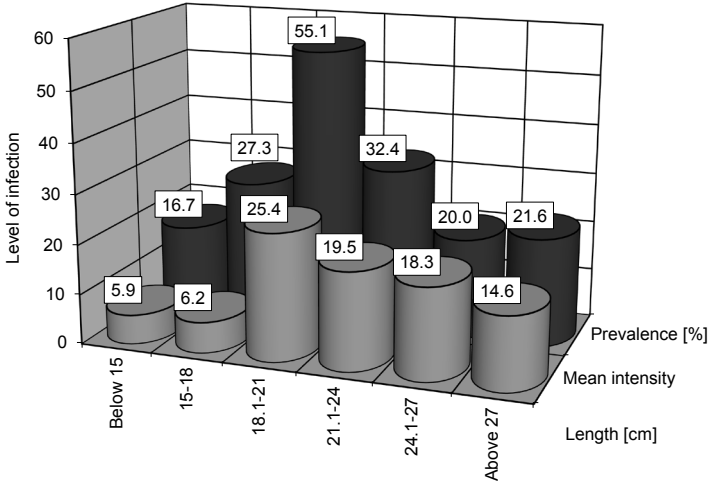
**Fig. 20.** Seasonal occurrence of *Diplostomum* spp. in European perch from Lake Raduńskie Dolne.



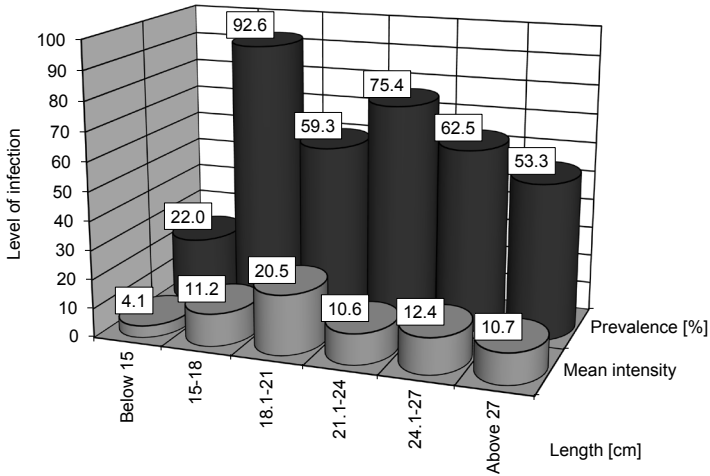
**Fig. 21.** Correlation between the occurrence of *Diplostomum* spp. and the roach length in Lake Żarnowieckie.



**Fig. 22.** Correlation between the mean intensity of *Diplostomum* spp. and the roach length in Lake Raduńskie Dolne.



**Fig. 23.** Correlation between the occurrence of *Diplostomum* spp. and the European perch length in Lake Żarnowieckie.



**Fig. 24.** Correlation between the occurrence of *Diplostomum* spp. and the European perch length in Lake Raduńskie Dolne.



A correlation was recorded between the intensity of metacercariae of *Tylodelphys clavata* from vitreous humor and the intensity of infection of lenses by *Diplostomum* spp. in European perch from Lake Żarnowieckie. With the intensity exceeding 100 digeneans in the vitreous humor, only single parasites were found in eye lenses or they were completely absent.

The level of infection in females and males of European perch from Lakes Żarnowieckie and Raduńskie Dolne was as follows: prevalence 19.0%, mean intensity 18.9, 47.3%, 16.9 and 47.3%, 11.9, 84.5%, 10.7, respectively. Whereas, the infection of females and males of roach from these lakes was 96.0%, 13.6, 93.8%, 9.8 and 100.0%, 16.5, 100.0%, 9.1, respectively.

#### *Ichthyocotylurus platycephalus* (Creplin, 1825), metacercaria

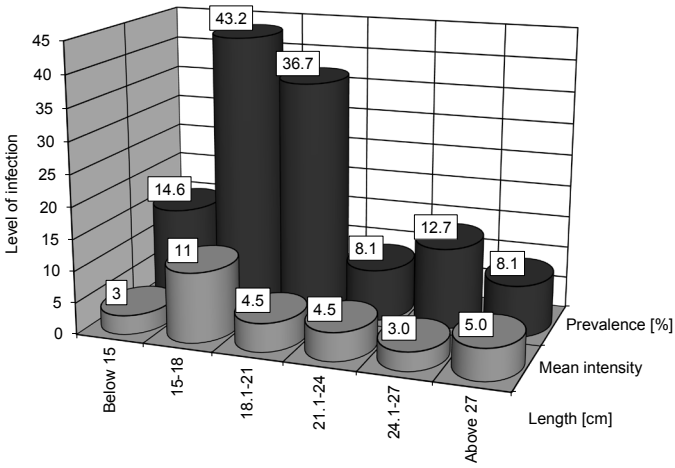
Metacercariae of this species were confirmed in both fish species examined and in both lakes, but the main host was European perch (Tables 3-6).

Parasites were collected from the aortic bulb (87.3%), fat tissues (3.6%), parietal peritoneum (3.6%), swim bladder wall (2.8%) and liver (2.7%).

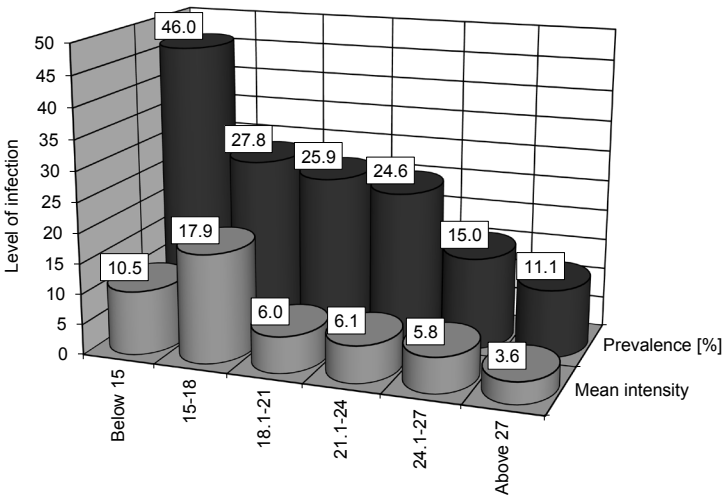
Since three species of digeneans from the genus *Ichthyocotylurus* were recorded with low infection rates, the parasites were considered as one taxon in order to test correlations between the occurrence of these metacercariae and the length and seasonality of European perch. In Lake Żarnowieckie, the most infected European perch were those measuring 15-18 cm in length (Fig. 25). In Lake Raduńskie Dolne higher prevalence was noted among specimens of European perch with the length below 15 cm ( $p < 0.05$ ), while the largest mean intensity – in fish with the length of 15-18 cm (Fig. 26).

The prevalence of this parasite in Lake Żarnowieckie varied in different seasons. In turn, the intensity was highest in fall. In Lake Raduńskie Dolne the highest infection was in summer and fall (and in one instance, the highest mean intensity was recorded in spring) ( $p < 0.0001$  for prevalence,  $p < 0.05$  for mean intensity for both lakes) (Fig. 27, 28).

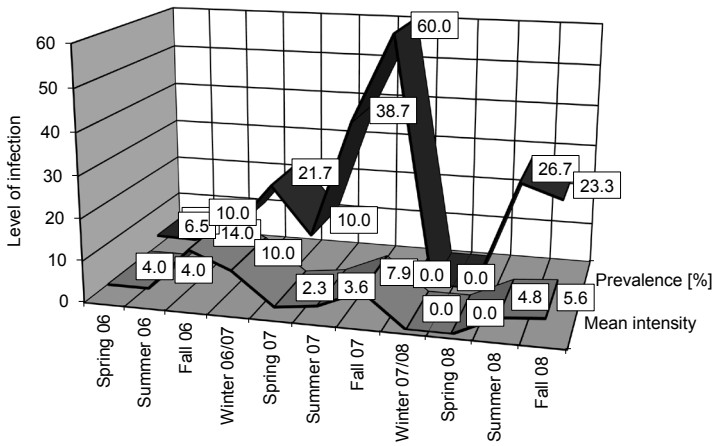
The infected roach from Lake Żarnowieckie were caught in spring and included three females (13.5-19.4 cm long), while those from Lake Raduńskie Dolne included two females (23.7 and 25.1 cm long, 23 parasites) and four males (17.4-19.5 cm long, 14 parasites). In turn, the infected European perch from Lake Żarnowieckie included six females with 32 digeneans and eight males with 22 parasites, while in Lake Raduńskie Dolne there were five females with 52 and nine males with 72 metacercariae.



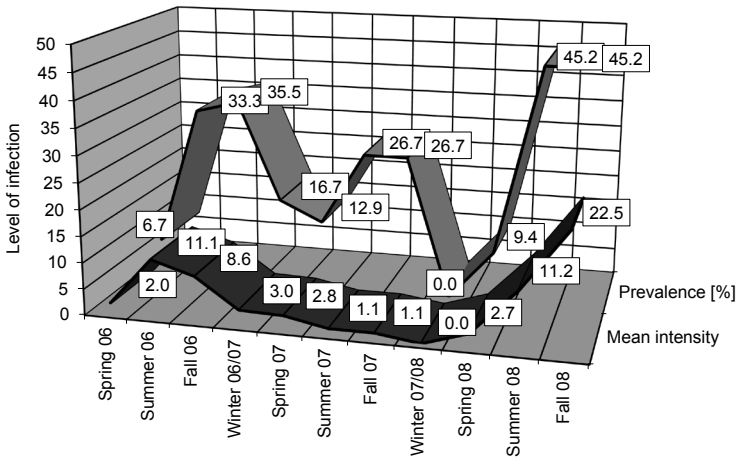
**Fig. 25.** Correlation between the occurrence of *Ichthyocotylurus* spp. and the European perch length in Lake Żarnowieckie.



**Fig. 26.** Correlation between the occurrence of *Ichthyocotylurus* spp. and the European perch length in Lake Raduńskie Dolne.



**Fig. 27.** Seasonal occurrence of *Ichthyocotylurus* spp. in European perch from Lake Żarnowieckie.



**Fig. 28.** Seasonal occurrence of *Ichthyocotylurus* spp. in European perch from Lake Raduńskie Dolne.

*Ichthyocotylurus pileatus* (Rudolphi, 1802), metacercaria

Metacercariae of this species were confirmed in European perch from both lakes and in roach from Lake Raduńskie Dolne. Higher parameters of infection were recorded for the European perch (Tables 4-6).

Nine infected roach specimens were caught in fall (3 ♀♀, 13.8-16.3 cm in length, and 6 ♂♂, 11.8-17.4 cm in length) in which 12 digeneans were found. In Lake Żarnowieckie, 97 parasites were found in 17 European perch females and 83 in nine European perch males, while in Lake Raduńskie Dolne – 252 digeneans were found in ten European perch females and 115 in 11 European perch males.

These parasites were located in the swim bladder (62.6 %), the kidneys (28.8 %) and the parietal peritoneum (8.6 %).

*Ichthyocotylurus variegatus* (Creplin, 1825), metacercaria

These digeneans were found only in European perch, and prevalence was higher in Lake Raduńskie Dolne, while the largest mean intensity was noted in Lake Żarnowieckie (Tables 5, 6).

These parasites were located in the swim bladder (58.9 %), the livers (21.7 %) and the parietal peritoneum (19.4 %).

The infection of European perch females and males from Lake Raduńskie Dolne was as follows: prevalence 10.8%, mean intensity 5.7 and 15.0%, 5.4, respectively. However, in Lake Żarnowieckie – 2.9%, 8.7 and 3.6%, 5.8, respectively.

*Paleorchis incognitus* Szidat, 1943

In summer 2007, eight adult digeneans (with eggs in their uteruses) of this species were found in five roach (3 ♀♀, 22.2-23.4 cm long, 2 ♂♂, 19.1 and 19.8 cm long) from Lake Raduńskie Dolne (Table 4). This parasite was confirmed in the intestine.

*Paracoenogonimus ovatus* Katsurada, 1914, metacercaria

In Lake Raduńskie Dolne, 321 parasites of this species were found in five female roach, while 87 digeneans were confirmed in seven males (Table 4).

The parasites were found in small fish (12.5-13.3 cm long), and the infected fish were found in fall (285 specimens) and winter (123).

Metacercariae of this species were located in the muscles of the trunk and the abdomen of the fish. With the density exceeding four cysts per 1 cm<sup>2</sup>, tissue softening and hemorrhaging were observed in the muscle tissue of the roach.

*Phyllodistomum folium* (Olfers, 1816)

Digeneans of this species were confirmed in the urinary bladder of three females (18.9-27.9 cm long) and five males (23.1-27.1 cm long) of the European perch from Lake Raduńskie Dolne (Table 6). The parasites were found in the summers of 2006 (2 specimens) and 2007 (12 specimens), and all of them had uteruses filled with mature eggs.

*Posthodiplostomum cuticola* (Nordmann, 1832), metacercaria

These digeneans were recorded in or on the roach from both lakes, but the infection parameters in fish from Lake Raduńskie Dolne were higher (Table 3, 4).

The highest infection parameters were recorded for the fish during the spring and summer periods ( $p < 0.05$  and  $p < 0.01$  for prevalence in Lake Żarnowieckie and Lake Raduńskie Dolne, respectively and  $p < 0.0001$  for mean intensity for both lakes) (Figs 29, 30).

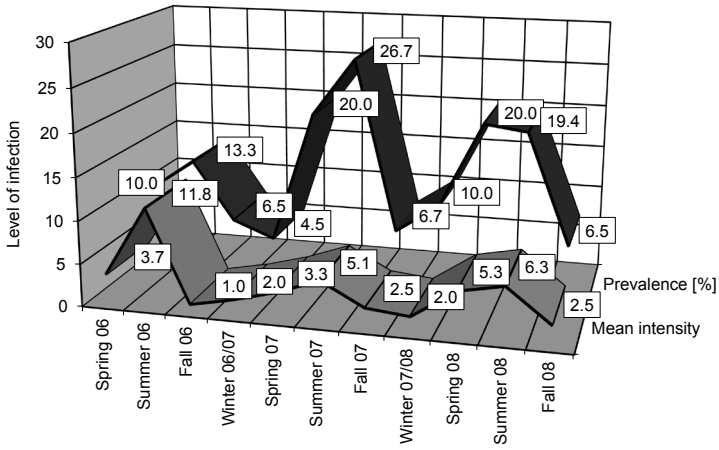
An increase was recorded in the infection corresponding to fish length ( $p < 0.05$  for prevalence in both lakes,  $p < 0.01$  for mean intensity in Lake Żarnowieckie) (Figs 31, 32).

Cysts with metacercaria were found most frequently on the fins (281 specimens in the space between rays and 84 on the fin rays). Slightly fewer digeneans were located on the body, and these were primarily under the skin or in the muscles (224 specimens), and they occurred less frequently on fish scales (58). They were also found in the oral cavity, mainly on the palate (51 specimens) and on the gills (18 specimens on gill filaments and 15 specimens on the bony gill arch). Among the gill arches, these parasites preferred the second gill arch (21 specimens), followed by the first and the fourth one (5 specimens each), with the fewest on the third (2 specimens) gill arch. In the case of the fins, the digeneans preferred, in the descending order or preference, the pectoral (105 specimens), the caudal (101), the pelvic (72), the anal (60) and the dorsal fins (27).

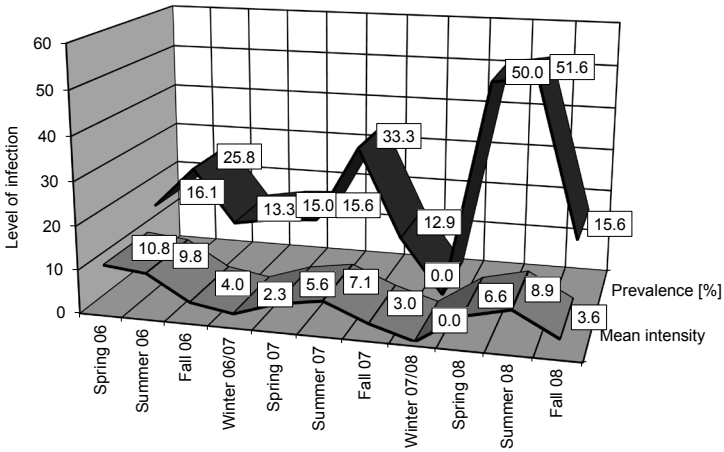
The level of infection in female and male roach from Lakes Żarnowieckie and Raduńskie Dolne was as follows: prevalence 15.8%, mean intensity 7.9, 10.2%, 6.4 and 28.4%, 8.3, 20.1%, 4.7, respectively.

*Rhipidocotyle campanula* (Dujardin, 1845), metacercaria

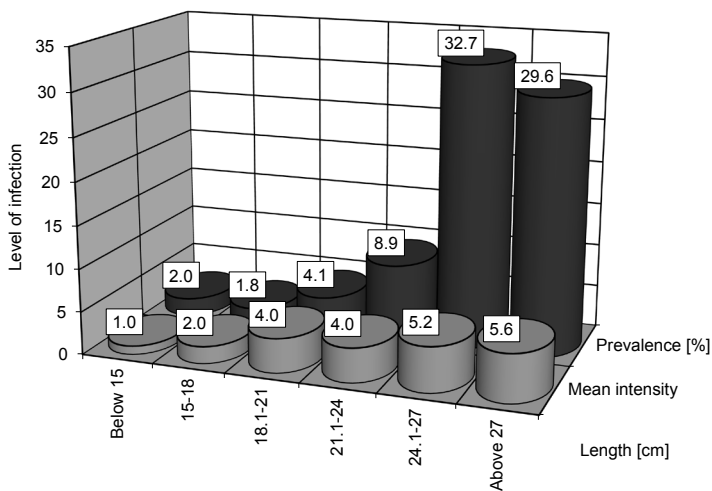
Metacercariae of this species were confirmed in roach and European perch from Lake Raduńskie Dolne (Table 4, 6).



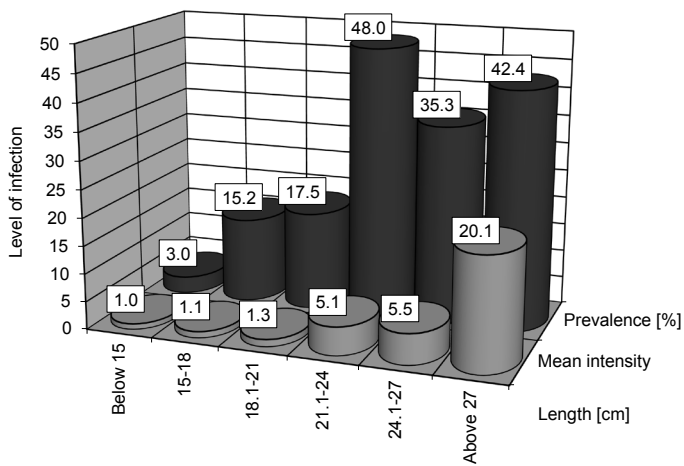
**Fig. 29.** Seasonal occurrence of *Posthodiplostomum cuticola* in roach from Lake Żarnowieckie.



**Fig. 30.** Seasonal occurrence of *Posthodiplostomum cuticola* in roach from Lake Raduńskie Dolne.



**Fig. 31.** Correlation between the occurrence of *Posthodiplostomum cuticola* and the roach length in Lake Żarnowieckie.



**Fig. 32.** Correlation between the occurrence of *Posthodiplostomum cuticola* and the roach length in Lake Radońskie Dolne.

These digeneans were confirmed on European perch on one female (19.9 cm long) and six males (13.5-15.8 cm long). They were found in the summer (15 specimens) and fall periods (14).

The highest infection parameters were recorded on roach during the summer period ( $p < 0.0001$  for prevalence) (Fig. 33).

Differences in infection depended on the roach length. Metacercariae occurred mainly in fish shorter than 18.0 cm. Single specimens were also found in fish from the length classes 21.1-24 and 24.1-27 cm (Fig. 34).

The parasites were located primarily on the pectoral (54 specimens) and caudal fins (39), rarely on the dorsal fins (3), and they preferred the space between the rays (90 specimens) over the rays themselves (6).

The female roach (17.8%, 1.7) were more strongly infected than the males (9.7%, 1.3).

#### *Rhipidocotyle campanula* (Dujardin, 1845), adult

Adult digeneans were found only in the European perch from Lake Raduńskie Dolne (Table 6). Eight females (23.2-25.7 cm long) and ten males (28.1-29.2 cm long) of the European perch were infected, and the parasites were found in the summer (8 specimens) and fall periods (18 specimens). Parasites were collected from the fish intestine. Twenty-two digeneans have uteruses filled with mature eggs.

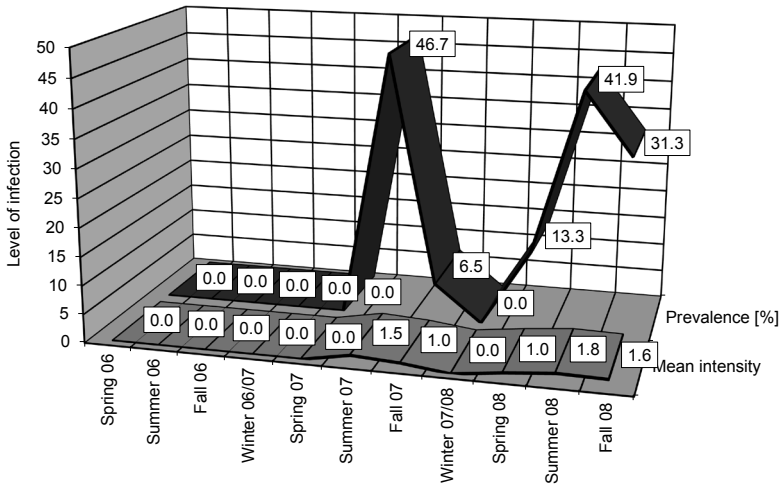
#### *Sphaerostomum bramae* (Müller, 1776)

In Lake Żarnowieckie, 12 digeneans of this species were found in one female roach (31.7 cm long), while there were 20 parasites in two males (22.7 and 22.8 cm long) (Table 3). In Lake Raduńskie Dolne, five female roach (27.3-27.4 cm long) with seven parasites and four male roach (22.1-22.9 cm long) with five digeneans were confirmed (Table 4). These parasites had uteruses carrying eggs, and the specimens were found in the fish intestines in the summer period.

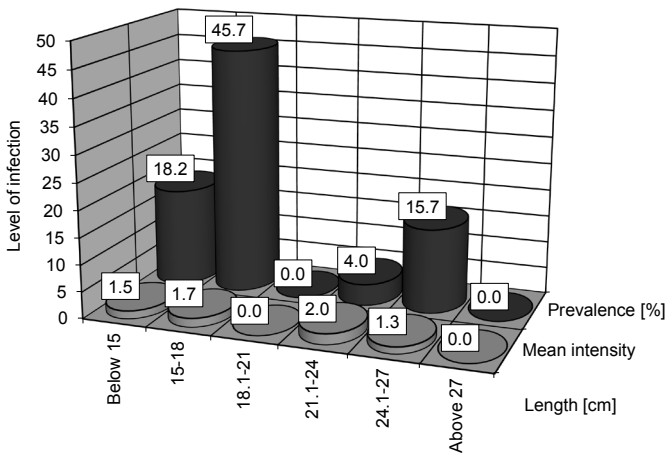
#### *Sphaerostomum globiporum* (Rudolphi, 1802)

Six and 22 digeneans of this species were found in the intestines of four females (18.3-23.9 cm long) and 14 males (17.1-18.4 cm long) of roach from Lake Raduńskie Dolne, respectively (Table 4). They were collected in the summer 2006 (12 specimens) and the fall 2007 (16 specimens). These specimens had uteruses with mature eggs.





**Fig. 33.** Seasonal occurrence of *Rhipidocotyle campanula* in roach from Lake Raduńskie Dolne.



**Fig. 34.** Correlation between the occurrence of *Rhipidocotyle campanula* and the roach length in Lake Raduńskie Dolne.

*Tylodelphys clavata* (Nordmann, 1832), metacercaria

Metacercariae of this species were found in the vitreous humor of European perch and roach from both lakes. Comparable and very high prevalence was recorded in the roach from both lakes and in the European perch from Lake Raduńskie Dolne; however, higher mean intensity of infection was confirmed in European perch (Tables 3-6).

The level of infection in fish was variable in different seasons of the year (Figs 35-38). In roach, these digeneans occurred mainly in fall ( $p < 0.0001$  for prevalence in Lake Żarnowieckie,  $p < 0.001$  for mean intensity for both lakes) and in European perch in summer and fall ( $p < 0.01$  for prevalence in Lake Raduńskie Dolne and Lake Żarnowieckie).

The prevalence in roach of all length classes was high, but the maximum was recorded in roach from Lake Raduńskie Dolne in the fish from the length range of 24.1-27 cm ( $p < 0.05$ ), while in Lake Żarnowieckie the maximum was recorded in fish from the length classes of 18.1-21 and 24.1-27 cm (Figs 39, 40). The highest values of mean intensity ( $p < 0.01$ ) were recorded in roach from the length category of 24.1-27 cm.

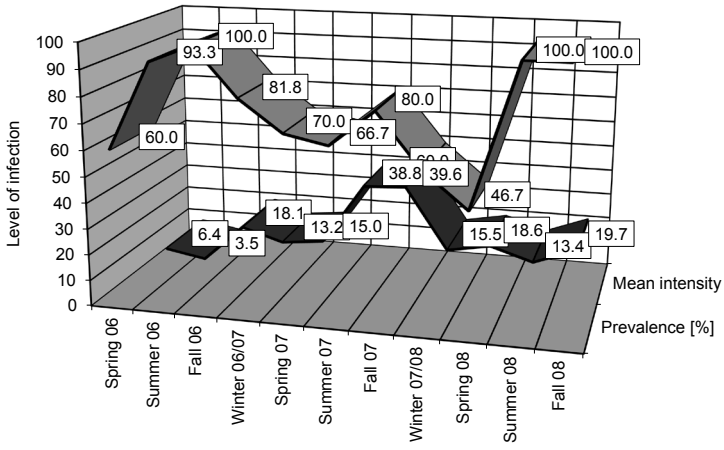
In European perch from Lake Żarnowieckie, the highest prevalence was recorded in fish from the length class of 24.1-27 cm ( $p < 0.05$ ), while the mean intensity value increased with the fish length ( $p < 0.001$ ) (Fig. 41). In Lake Raduńskie Dolne, the most strongly infected European perch were from the length class of 21.1-24 cm ( $p < 0.05$  for mean intensity) (Fig. 42).

The infection parameters of females and males of the European perch from Lake Raduńskie Dolne were, respectively, prevalence 93.5%, mean intensity 55.6 and 60.3%, 44.8, while in Lake Żarnowieckie they were, respectively, 44.1%, 91.4, and 50.0%, 97.0. In turn, the infection of female and male roach from these lakes was as follows: prevalence 93.5%, mean intensity 22.6, 70.1%, 16.4, and 89.3%, 20.3, 65.6%, 14.5 respectively.

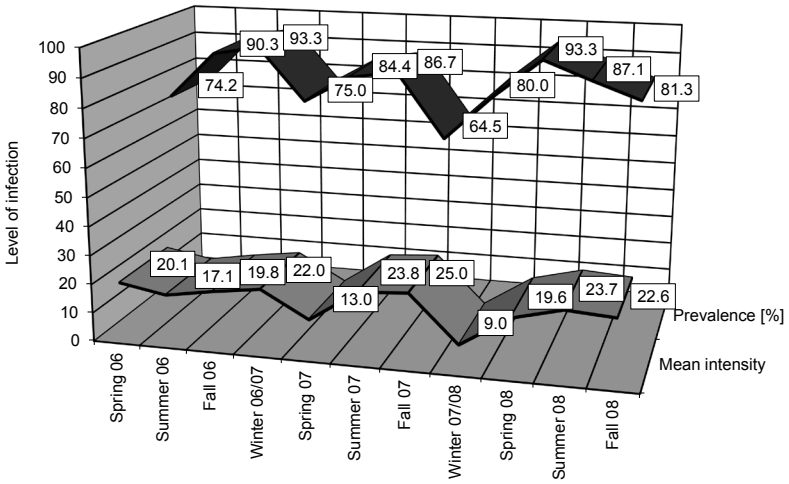
## Digenea, n.det., metacercaria

In fall 2006, 50 digeneans (dead specimens) were found in three female roach (13.9-16.9 cm long) and 27 in two males (14.8 and 17.7 cm long). These fishes were from Lake Raduńskie Dolne (Table 4).

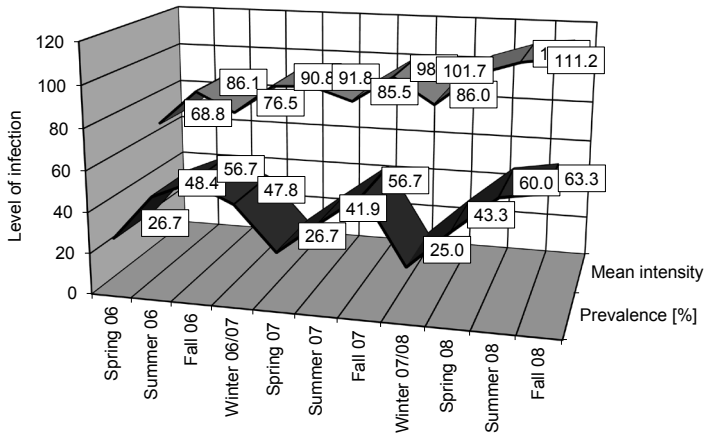
The parasites were collected from the vicinity of oral cavities (38 specimens), eyes (9) and opercular membranes (30) of the fish. Metacercariae were encysted, with an oval shape and thin walls measuring ( $n=15$ ) 0.167-0.168  $\times$  0.158-0.161 mm (mean 0.167  $\times$  0.160,  $\pm$ SD 0.005  $\times$  0.001).



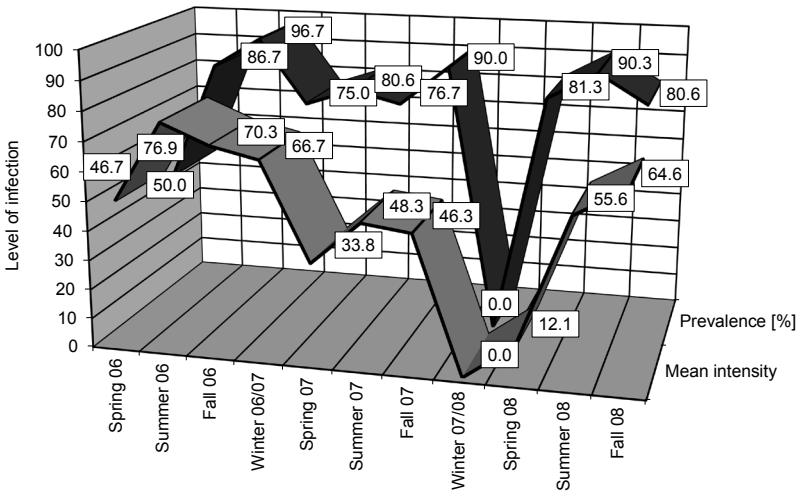
**Fig. 35.** Seasonal occurrence of *Tyloodelphys clavata* in roach from Lake Żarnowieckie.



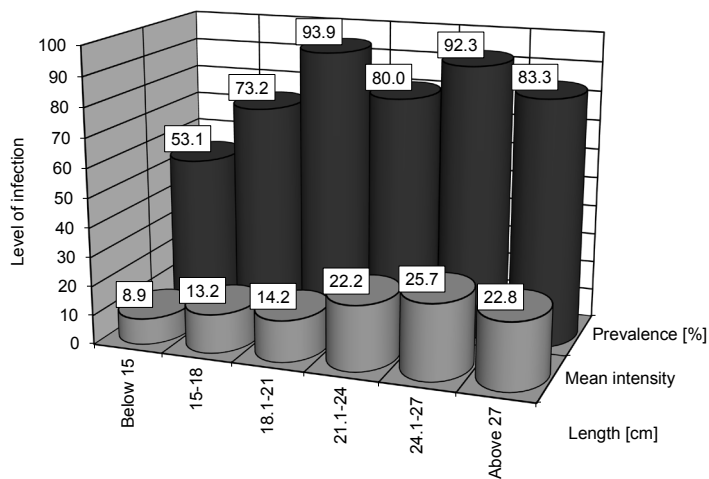
**Fig. 36.** Seasonal occurrence of *Tyloodelphys clavata* in roach from Lake Raduńskie Dolne.



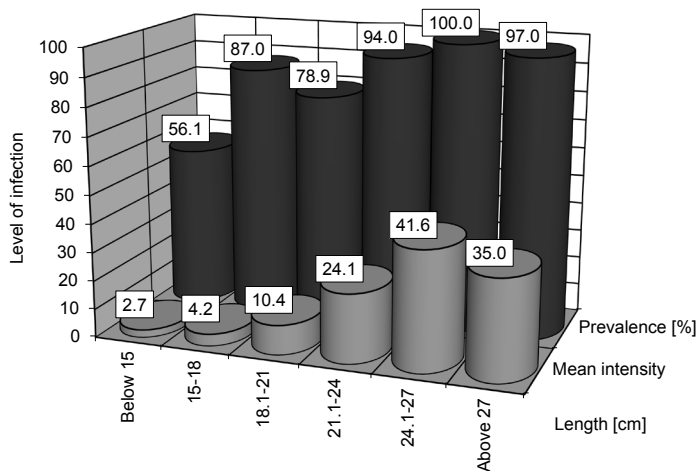
**Fig. 37.** Seasonal occurrence of *Tyloodelphys clavata* in European perch from Lake Żarnowieckie.



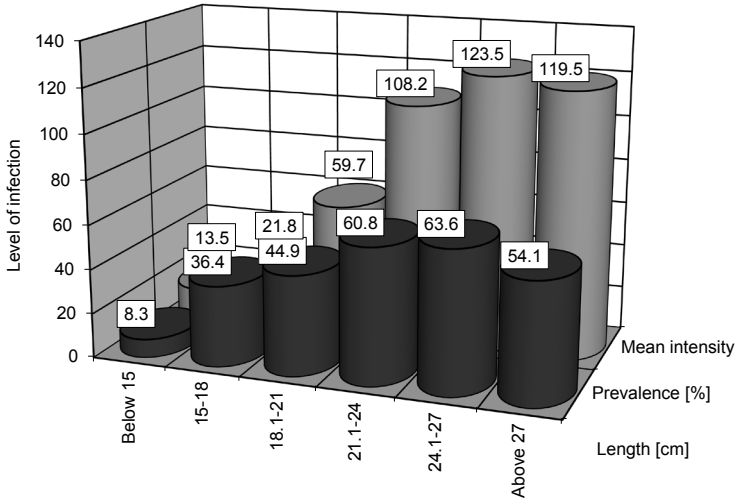
**Fig. 38.** Seasonal occurrence of *Tyloodelphys clavata* in European perch from Lake Raduńskie Dolne.



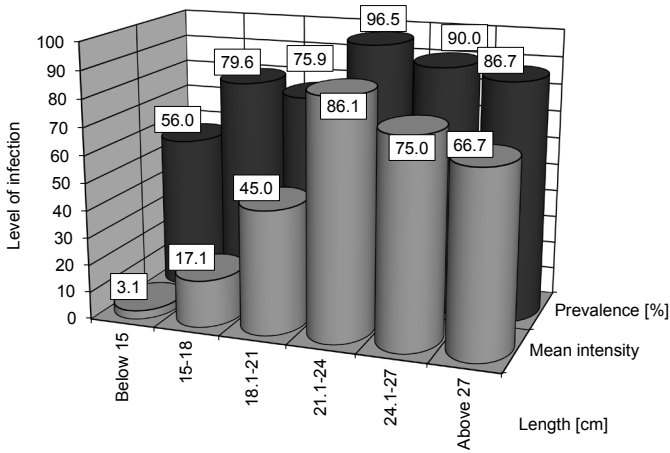
**Fig. 39.** Correlation between the occurrence of *Tyloodelphys clavata* and the roach length in Lake Żarnowieckie.



**Fig. 40.** Correlation between the occurrence of *Tyloodelphys clavata* and the roach length in Lake Raduńskie Dolne.



**Fig. 41.** Correlation between the occurrence of *Tyloodelphys clavata* and the European perch length in Lake Żarnowieckie.



**Fig. 42.** Correlation between the occurrence of *Tyloodelphys clavata* and the European perch length in Lake Raduńskie Dolne.

### 3. Cestoda

#### *Caryophyllaeides fennica* (Schneider, 1902)

In Lake Raduńskie Dolne, 17 parasites were confirmed in five female roach (14.1-19.2 cm long), and 16 parasites were found in seven males (17.2-21.3 cm long) (Table 4). In Lake Żarnowieckie, 12 tapeworms of this species were found in 5 roach females (14.7-21.7 cm long) and 10 parasites in seven males (22.7-22.9 cm long) (Table 3). Cestodes were found in the intestines in the spring (3 specimens in Lake Żarnowieckie and 11 specimens in Lake Raduńskie Dolne) and in the summer (19 and 22 specimens respectively).

#### *Caryophylleus laticeps* (Pallas, 1781)

In Lake Raduńskie Dolne these cestodes were found in three roach (♀♀, 12.5-15.7 cm long) (Table 4). The parasites were found in the intestines in the fall period of 2007 (4 specimens) and in 2008 (1).

#### *Eubothrium crassum* (Bloch, 1779), plerocercoid

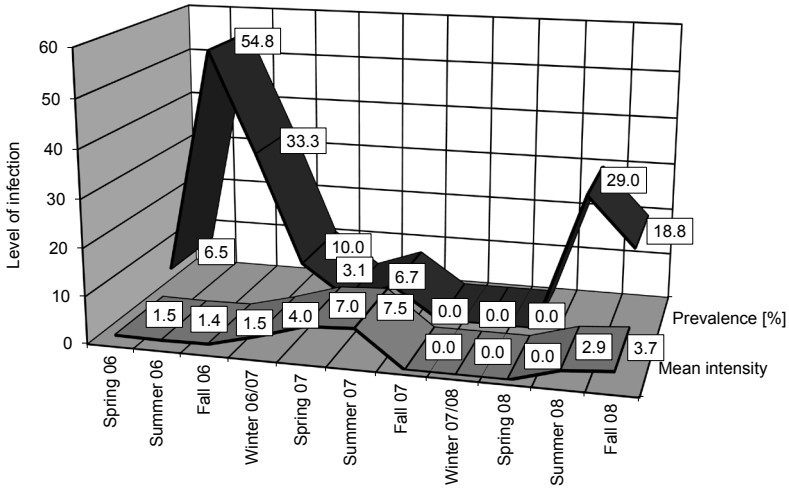
These cestodes were confirmed in the pyloric caeca of European perch (2 ♀♀, 9.1 and 11.6 cm long, 4 ♂♂, 10.2-12.3 cm long) from Lake Żarnowieckie (Table 5). They were recorded in the summer of 2006 (6 specimens) and 2007 (2 specimens).

#### *Paradilepis scolecina* (Rudolphi, 1819), plerocercus

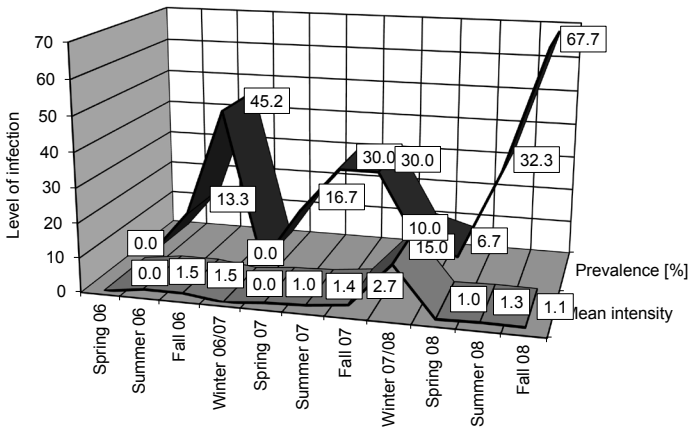
These tapeworms were found in roach from both lakes (Table 3, 4). This parasite was confirmed in the wall of the intestine (240 specimens) and in the wall of the stomach (2 specimens).

A correlation was confirmed in the occurrence of tapeworms between prevalence and season of the year ( $p < 0.0001$ ). In Lake Raduńskie Dolne, the highest infection rates were recorded in summer, while in Lake Żarnowieckie in the fall. However, in Lake Żarnowieckie in the season of 2007, similar values of prevalence were recorded in the summer and fall (Figs 43, 44).

In roach from lake Żarnowieckie, initially the prevalence increased with the fish length reaching the maximum in the fish length class of 15-18 cm, after which it decreased dramatically ( $p < 0.01$ ) (Fig. 45). The highest prevalence in roach from Lake Raduńskie Dolne was recorded in fish measuring 18.1-21 cm ( $p < 0.05$ ) (Fig. 46). However, mean infection reached the maximum in Lake Żarnowieckie in the fish length class of 18.1-21 cm and in Lake Raduńskie Dolne in fish from the length class 15-18 cm (Fig. 45, 46).

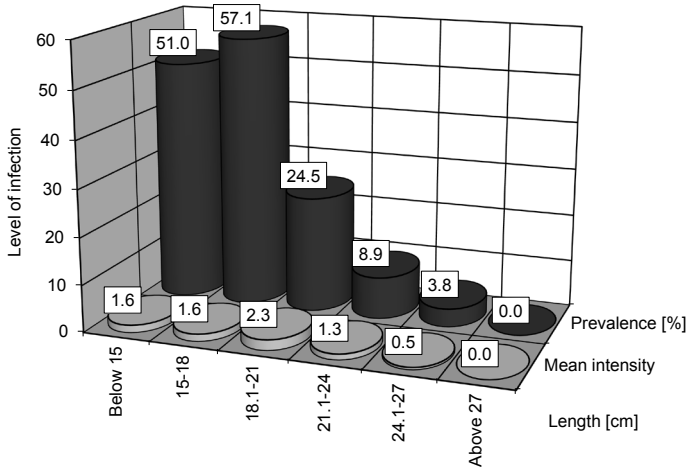


**Fig. 43.** Seasonal occurrence of *Paradilepis scolecina* in roach from Lake Raduńskie Dolne.

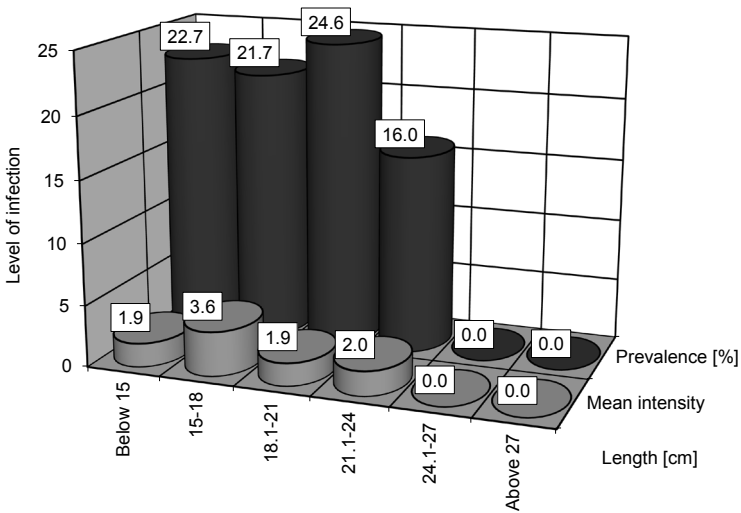


**Fig. 44.** Seasonal occurrence of *Paradilepis scolecina* in roach from Lake Żarnowieckie.





**Fig. 45.** Correlation between the occurrence of *Paradilepis scolecina* and the roach length in Lake Żarnowieckie.



**Fig. 46.** Correlation between the occurrence of *Paradilepis scolecina* and the roach length in Lake Raduńskie Dolne.

The infection of female and male roach from Lake Żarnowieckie was, respectively, prevalence 22.6%, mean intensity 2.0 and 27.3%, 1.3, while in Lake Raduńskie Dolne it was 18.3%, 2.5, and 13.4%, 2.4 respectively.

#### *Proteocephalus percae* (Müller, 1780)

These cestodes were found in the intestine of European perch from both lakes, but higher infection parameters were recorded for fish from Lake Raduńskie Dolne (Tables 5, 6).

A correlation between the occurrence of these parasites and the season of the year was revealed for the European perch from Lake Raduńskie Dolne. These tapeworms occurred mainly in summer ( $p < 0.0001$ ) (Fig. 47). Also in fish from Lake Żarnowieckie they were mainly recorded in summer (17 specimens), with fewer specimens in fall (3), and the least in spring (2).

The highest percentage of infected European perch from Lake Raduńskie Dolne was recorded in the fish of length range of 21.1-24 cm. The mean intensity of infection increased until the fish length class of 18.1-21 cm, after which it decreased (Fig. 48).

The level of infection in females and males of European perch from Lake Raduńskie Dolne was as follows: prevalence 7.6%, mean intensity 3.7 and 14.7%, 2.2, respectively. The infected fish from Lake Żarnowieckie were represented by eight females (18.3-19.4 cm long, 8 parasites) and eleven males (19.2-22.5 cm long, 14 parasites).

#### *Proteocephalus* spp.

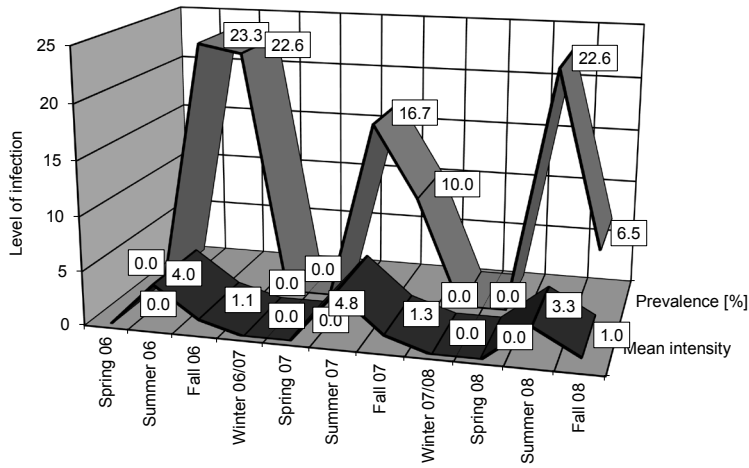
Juvenile cestodes (with an immature reproductive system) were found in the intestine of European perch (1♀, 15.2 cm long) from Lake Raduńskie Dolne (Table 6). They were recorded in the spring of 2007.

#### *Triaenophorus nodulosus* (Pallas, 1781), plerocerkoid

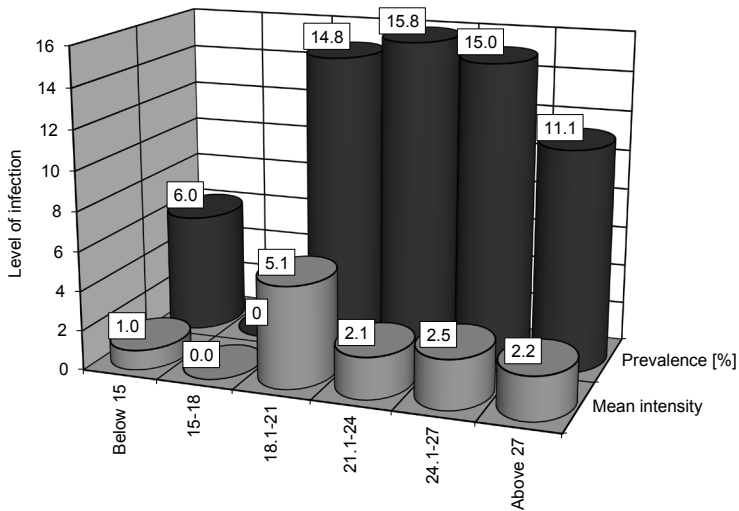
These tapeworms were found in European perch from both lakes, with higher infection parameters in the fish from Lake Raduńskie Dolne (Tables 5, 6).

*T. nodulosus* was recorded in Lake Żarnowieckie mostly in the spring and fall (Fig. 49), while in Lake Raduńskie Dolne they were usually found in summer ( $p < 0.05$  for prevalence) (Fig. 50).

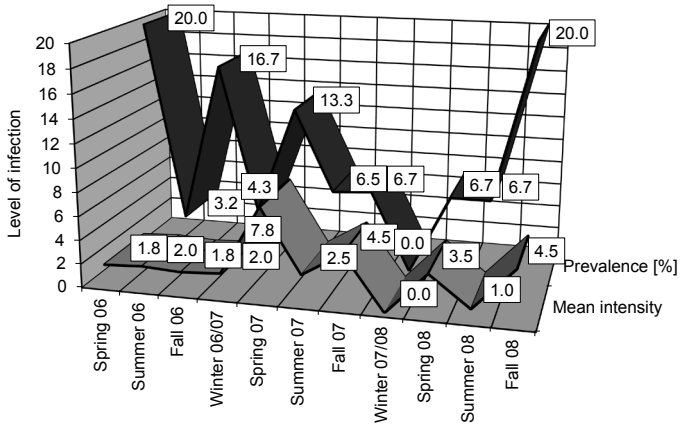
In lake Żarnowieckie parasites were recorded primarily in the fish length classes of 18.1-21 cm (Fig. 51), while in the Raduńskie Dolne they were recorded in the fish length classes of 18.1-21 cm and 24.1-27 cm (Fig. 52).



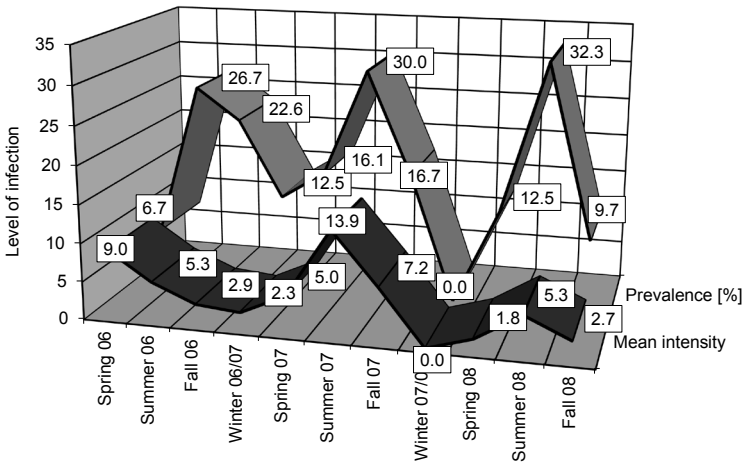
**Fig. 47.** Seasonal occurrence of *Proteocephalus percae* in European perch from Lake Raduńskie Dolne.



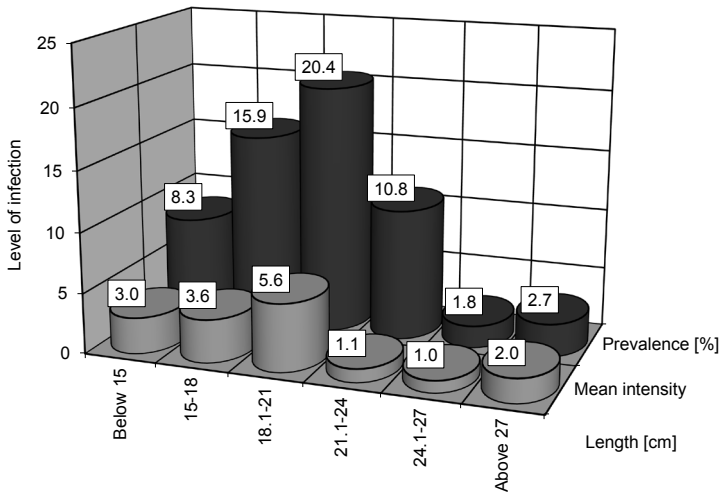
**Fig. 48.** Correlation between the occurrence of *Proteocephalus percae* and the European perch length in Lake Raduńskie Dolne.



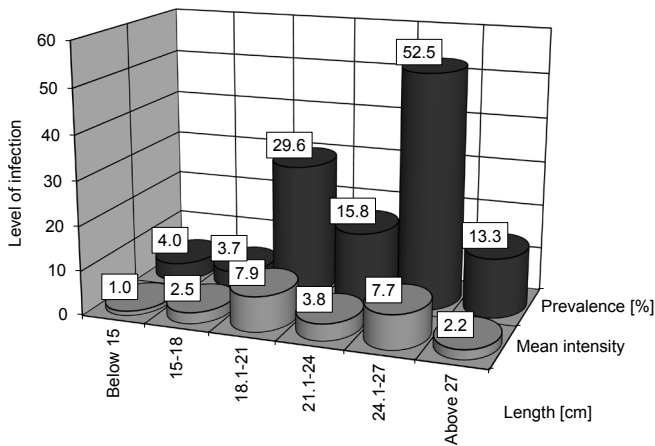
**Fig. 49.** Seasonal occurrence of *Triaenophorus nodulosus* in European perch from Lake Żarnowieckie.



**Fig. 50.** Seasonal occurrence of *Triaenophorus nodulosus* in European perch from Lake Raduńskie Dolne.



**Fig. 51.** Correlation between the occurrence of *Triaenophorus nodulosus* and the European perch length in Lake Żarnowieckie.



**Fig. 52.** Correlation between the occurrence of *Triaenophorus nodulosus* and the European perch length in Lake Raduńskie Dolne.

The parasites were encysted in the livers. While there was usually one cestode in each cyst, two of them were confirmed in 32 cysts, and three in 15 cysts. Fifteen cysts contained dead cestodes.

The level of infection among males of European perch (prevalence 17.0 %, mean intensity 3.5) in Lake Żarnowieckie was higher than in females (6.2 %, 3.2), but in Lake Raduńskie Dolne the females (22.3 %, 6.5) revealed higher infection rates than the males (12.9%, 5.1).

#### 4. Nematoda

*Anguillicoloides crassus* (Kuwahara, Niimi et Itagaki, 1974), L3

*A. crassus* larvae were found in two females (13.4 and 13.9 cm long) and six males (14.3-14.9 cm long) of the European perch from Lake Raduńskie Dolne (Table 6). These nematodes were found in the intestinal walls in the summer period of 2007.

*Anisakis simplex* (Rudolphi, 1809), L3

The nematodes *A. simplex* were confirmed in European perch (1♀, 35.0 cm long) from Lake Żarnowieckie (Table 5). The parasites were found in spring of 2006 and were encysted on the pyloric caeca of the fish.

Since *A. simplex* was confirmed for the first time in the European perch from Poland, their morphometric data are presented (in mm). Measurements were taken after the nematodes had been fixed and cleared.

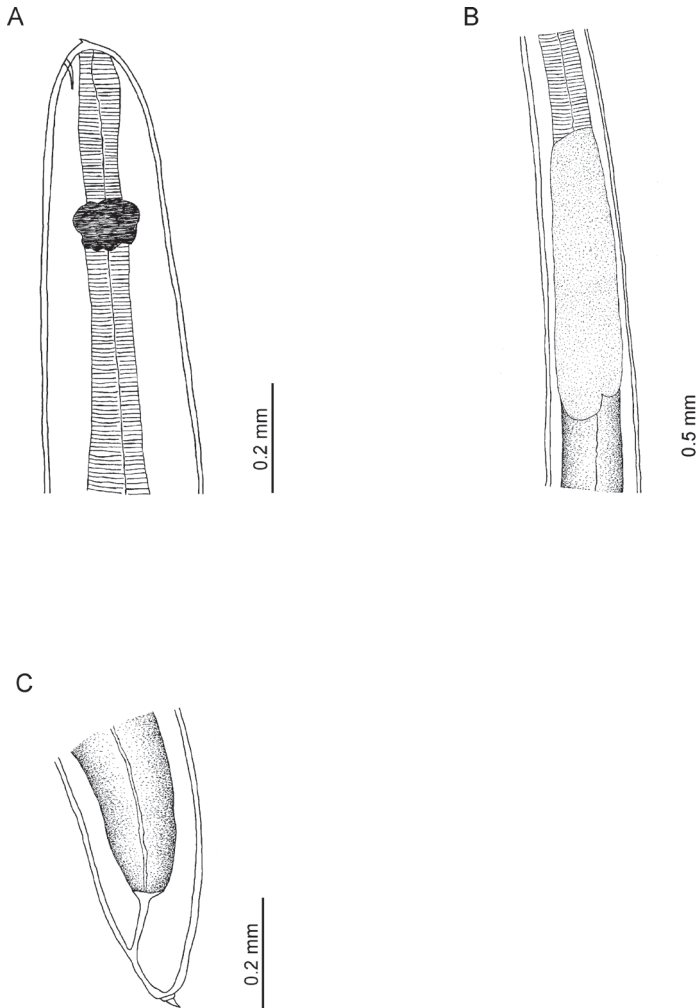
Description (n=2, Fig. 53):

the body (the maximum length and the maximum width) of the first and second specimens respectively  $23.1 \times 0.65$ ,  $28.0 \times 0.54$ ; the body width at the level of the nerve ring 0.153, 0.183; length and width of the base of the larval (boring) tooth  $0.008 \times 0.01$ ,  $0.016 \times 0.018$ ; the excretory pore situated 0.027, 0.029 away from the anterior extremity; oesophagus  $1.89 \times 0.17$ ,  $2.19 \times 0.18$ ; distance of the nerve ring from the anterior extremity 0.26, 0.28; ventriculus  $1.10 \times 0.23$ ,  $1.21 \times 0.26$ ; ventriculus obliquely connected with the intestine; tail length 0.095, 0.11; mucron length 0.018, 0.033.

*Camallanus lacustris* (Zoega, 1776)

This nematode species was found in European perch from both lakes, but infection parameters were higher in the fish from Lake Raduńskie Dolne (Tables 5, 6).

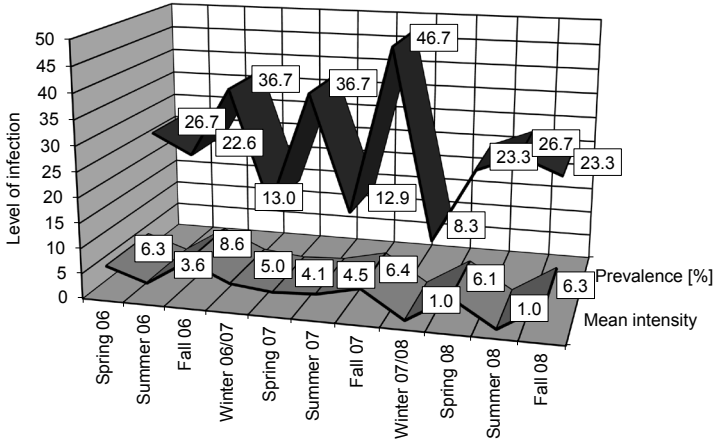
Generally, two peaks of the parasite occurrence were observed in spring and fall in Lake Żarnowieckie, while in Lake Raduńskie Dolne the increased



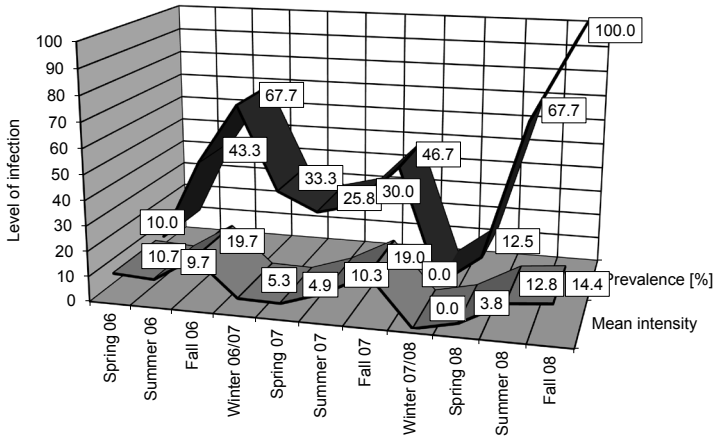
**Fig. 53.** *Anisakis simplex*, L3 from a body cavity of European perch from Lake Żarnowieckie; A: anterior end, B: region of ventriculus, C: tail.

infection was observed in subsequent seasons with the maximum infection rate in the fall ( $p < 0.05$  and  $p < 0.0001$  for prevalence in Lakes Żarnowieckie and Radduńskie Dolne, respectively,  $p < 0.01$  for mean intensity for both lakes) (Fig. 54, 55).

Among fishes from Lake Żarnowieckie, the most strongly infected were those from the length range of 24.1-27 cm ( $p < 0.05$ ). The mean infection rates in this length range and in the range above 27 cm were similar ( $p < 0.01$ ) (Fig. 56).



**Fig. 54.** Seasonal occurrence of *Camallanus lacustris* in European perch from Lake Żarnowieckie.



**Fig. 55.** Seasonal occurrence of *Camallanus lacustris* in European perch from Lake Raduńskie Dolne.



In Lake Raduńskie Dolne fishes from the length range of 18.1-21 cm were most strongly infected (Fig. 57).

The population structure of this nematode species collected from the fish from Lake Raduńskie Dolne was as follows: 425 (24.4%) adult females (with developed eggs in uteruses), 106 (6.1%) adult males, 809 (46.5%) juvenile females (uteruses without eggs) and 401 (23.0%) juvenile males. In Lake Żarnowieckie, the following population structure was observed: 197 (45.5%) adult females (with developed eggs in uteruses), 37 (8.5%) adult males, 129 (29.8%) juvenile females (uteruses without eggs) and 70 (16.2%) juvenile males.

In Lake Raduńskie Dolne most of the juvenile nematodes were found in fall (806 specimens) and in summer (388), while in Lake Żarnowieckie they were found in fall (112 specimens) and spring (57).

The parasites were primarily located in the pyloric caeca (1155 juvenile and 488 adult nematodes) and less frequently in the intestine (244 and 277, respectively), and in the fish stomach (10 adults). The even distribution of nematode abundance was observed in all (four) pyloric caeca of European perch.

The infection of European perch females and males from Lake Żarnowieckie was as follows: prevalence 22.1%, mean intensity 6.3 and 33.9%, 4.3, respectively, while in Lake Raduńskie Dolne it was 41.8%, 14.7 and 47.4%, 11.0, respectively.

#### *Camallanus truncatus* (Rudolphi, 1814)

This species of nematode was confirmed in four females (19.9-21.3 cm long, 6 parasites) and four males of European perch (20.1-22.4 cm long, 6 parasites) in Lake Żarnowieckie (Table 5). All nematodes were adult and were collected in summer 2006 (7 ♀♀ i 2 ♂♂) and 2007 (3 ♀♀).

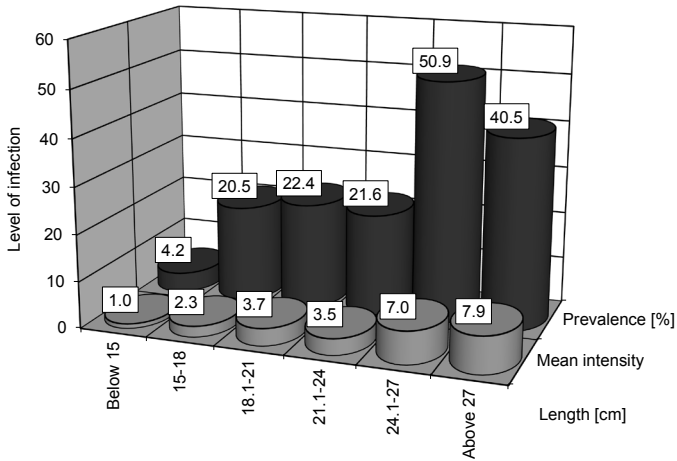
#### *Contracaecum* sp., L3

This species of nematode was found on two European perch (♂♂, 26.3 and 27.5 cm long) from Lake Raduńskie Dolne (Table 6), and it was collected from the surface of the intestine in the summer of 2006.

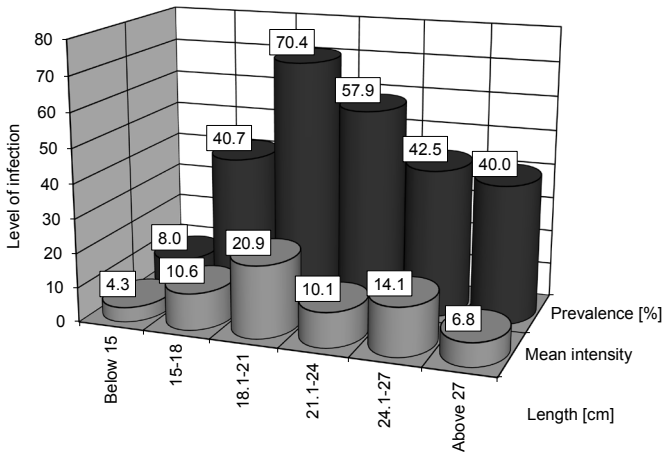
Since *Contracaecum* larvae in European perch were confirmed in Poland for the first time, their morphometric data are presented (mm). Measurements were taken after the nematodes had been fixed and cleared.

Description (n=2, Fig. 58):

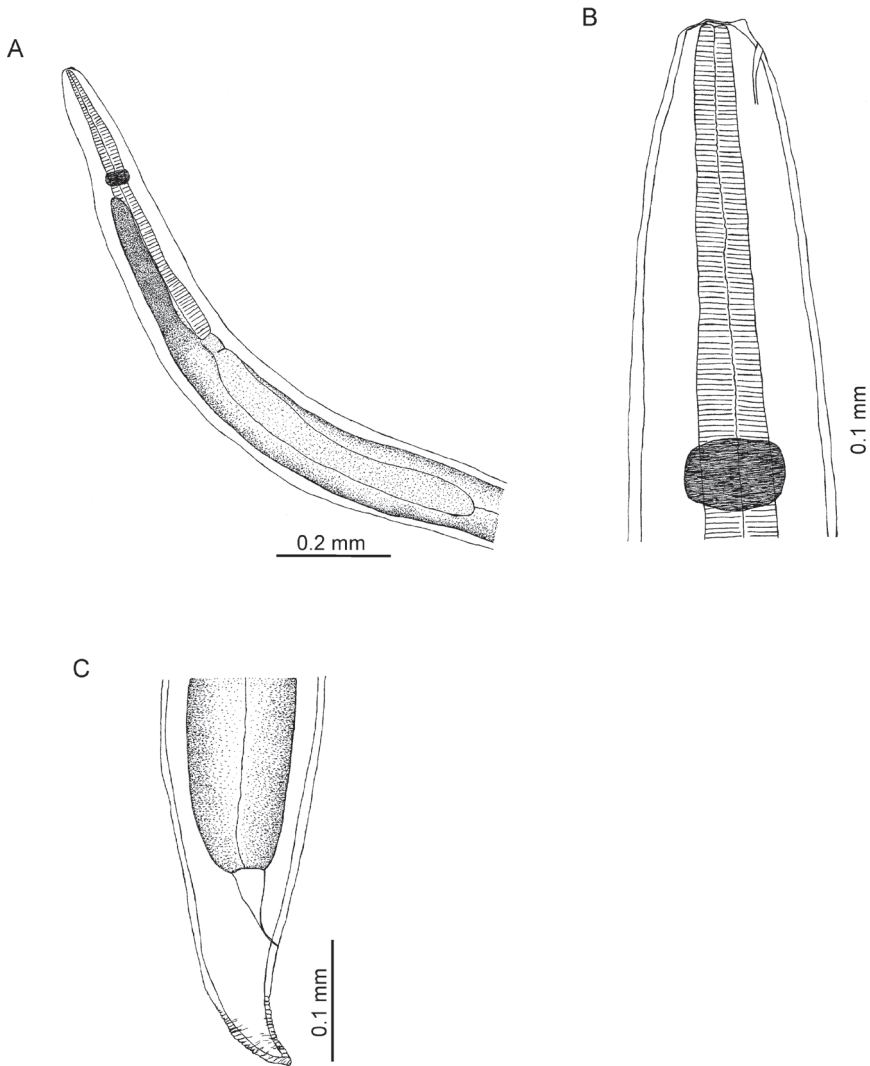
the nematodes were encysted in irregular, flat cysts. The bodies were striated and the length and the maximum width of the first and second specimens were respectively  $4.19 \times 0.16$ ,  $4.11 \times 0.15$ ; length of the larval (boring) tooth 0.007,



**Fig. 56.** Correlation between the occurrence of *Camallanus lacustris* and the European perch length in Lake Żarnowieckie.



**Fig. 57.** Correlation between the occurrence of *Camallanus lacustris* and the European perch length in Lake Raduńskie Dolne.



**Fig. 58.** *Contracaecum* sp., L3 from a body cavity of European perch from Lake Raduńskie Dolne; A: anterior end, B: head end, C: tail.

0.008; oesophagus  $0.475 \times 0.058$ ,  $0.474 \times 0.051$ ; ventriculus  $0.028 \times 0.029$ ,  $0.028 \times 0.030$ ; ventricular appendix  $0.459 \times 0.054$ ,  $0.379 \times 0.050$ ; intestinal caecum  $0.270 \times 0.051$ ,  $0.256 \times 0.040$ ; the excretory pore situated 0.018, 0.022 away from the anterior extremity; distance of the nerve ring from the anterior extremity 0.189, 0.190; tail 0.087, 0.086.

*Cosmocephalus obvelatus* (Creplin, 1825), L3

In Lake Raduńskie Dolne, six specimens of this nematode were found in six females (13.6-18.4 cm long) and two specimens in one female of the European perch (21.2 cm long) (Table 6). They were found in summer (8 specimens) of 2006. The nematodes were encysted in the fish intestinal wall. *C. obvelatus* was confirmed to occur in fish in Poland for the first time, besides it was recorded for the first time on the European perch, which is why their morphometric data are presented.

Description (n=6, measured after fixing and clearing, measurements in mm, Fig. 59):

oval, thick-walled cysts measuring 0.74-0.76 x 0.50-0.51 (mean 0.75 x 0.51,  $\pm$ SD 0.01 x 0.005) with coiled nematodes inside. Cuticle of the body with fine transverse striations. The anterior end with two triangular pseudolabia, on dorsoventral-view margins of pseudolabia in the form of two distinct parallel grooves. Two pairs of cephalic papillae located submedially at the base of pseudolabia. The body length and the maximum width 1.897-2.147 x 0.072-0.081 (mean 2.06 x 0.19,  $\pm$ SD 0.09 x 0.29), the length of the vestibule 0.093-0.098 (mean 0.097,  $\pm$ SD 0.002), the length of the muscular oesophagus 0.242-0.287 (mean 0.269,  $\pm$ SD 0.018), the length of the glandular oesophagus 0.752-0.820 (mean 0.792,  $\pm$ SD 0.03), distance between the nerve ring and the anterior extremity 0.117-0.121 (mean 0.119,  $\pm$ SD 0.002), distance between the excretory pore and the anterior extremity (not always visible) 0.126-139 (mean 0.132,  $\pm$ SD 0.005), the tail rounded 0.084-0.099 (mean 0.092,  $\pm$ SD 0.007).

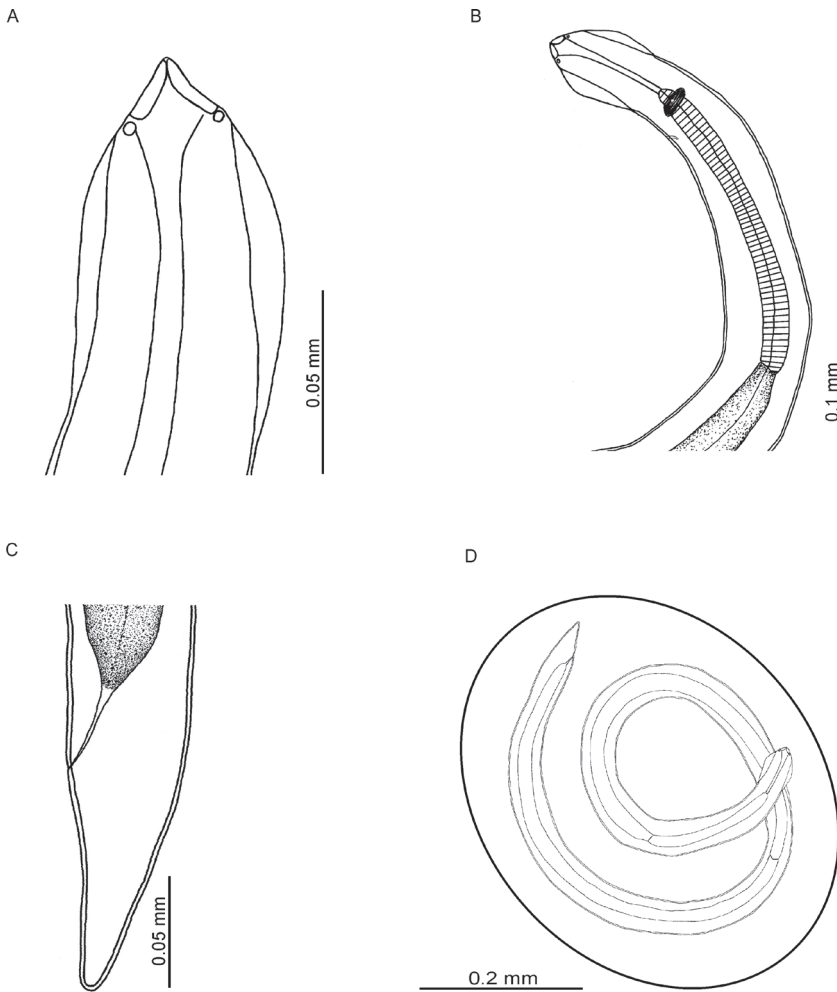
*Desmidocercella numidica* Seurat, 1920, L3

This nematode was found in two specimens of roach (♀♀, 19.9 and 21.0 cm long) from Lake Żarnowieckie (Table 3), and in two specimens of European perch (♀, 17.1 cm and ♂, 16.8 cm long) from Lake Raduńskie Dolne (Table 6). The parasites were collected in summer and they were located in the vitreous humor of fish.

*Eustrongylides excisus* Jägerskiöld, 1909, L4

Seven specimens of this nematode species were confirmed in two females (19.0 and 19.5 cm long) and 17 in five males (19.3-21.4 cm long) of European perch (Table 6). They were found in fall 2007 in Lake Raduńskie Dolne. The parasites included 5 males and 19 females, and they were located beneath the parietal peritoneum in the muscles of the fish trunk.

These parasitic larvae were confirmed in European perch from Poland for the first time which is why the morphometric data are included in this paper

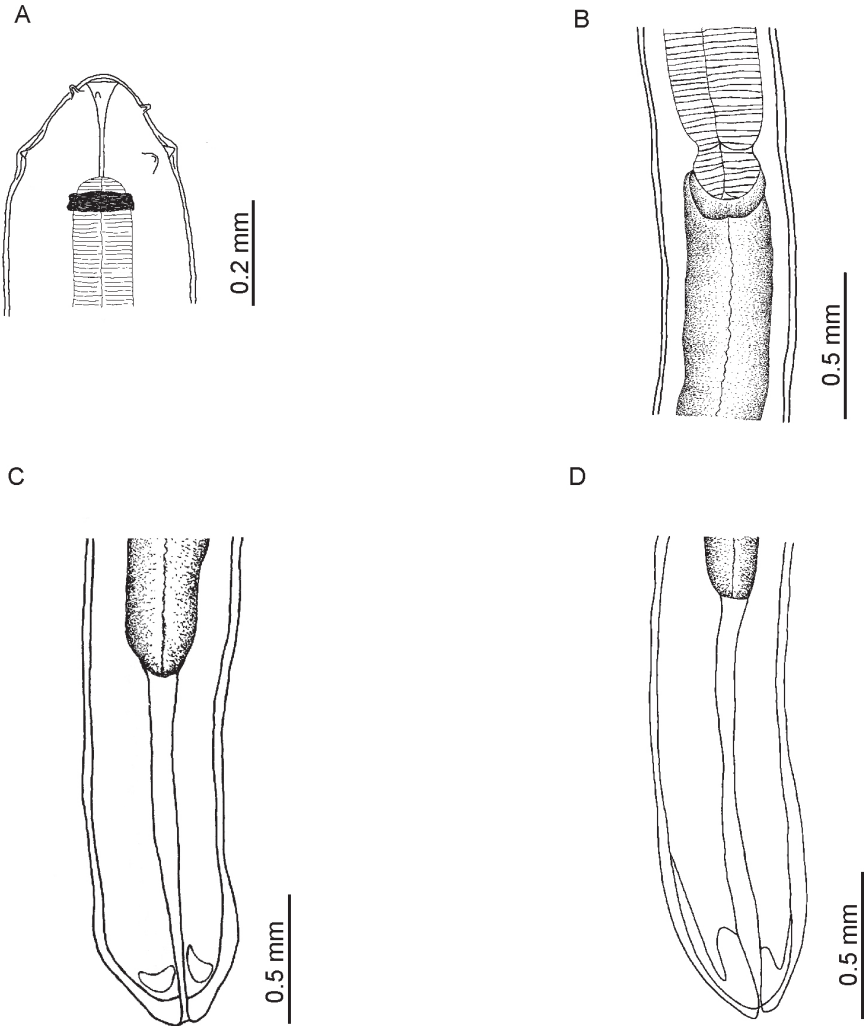


**Fig. 59.** *Cosmocephalus obvelatus* L3 from the intestinal wall of European perch from Lake Raduńskie Dolne; A: head end , B: anterior end of body, C: tail, D: general view, larvae in the cyst.

(mm). Measurements were taken after the nematodes had been fixed and cleared.

Description (Fig. 60):

the larvae were red-brown in color and coiled. The anterior end was rounded with 12 papillae arranged in two circles of six papillae each. The papillae in the



**Fig. 60.** *Eustrongylides excisus* L4 from muscles of European perch from Lake Raduńskie Dolne; A: head end, B: region of oesophagus and intestine, C: posterior end of male, D: posterior end of female.

inner circle are longer and finger-like, while those of the outer circle are conical with broader bases and blunt peaks. Terminal anal opening. Female (n=5): the body (length and maximum width)  $43.1-55.2 \times 0.48-0.93$  (mean  $49.9 \times 0.68$ ,  $\pm$ SD  $4.68 \times 0.21$ ); the body width at the inner circle of papillae  $0.088-0.095$

(mean 0.091,  $\pm$ SD 0.003); the body width at the outer circle of papillae 0.168-0.176 (mean 0.171,  $\pm$ SD 0.003), the body width at the nerve ring 0.234-0.45 (mean 0.313,  $\pm$ SD 0.108); length of the buccal cavity 0.157-0.168 (mean 0.164,  $\pm$ SD 0.005); the length and maximum width of the oesophagus 9.1-15.2  $\times$  0.166-0.393 (mean 12.1  $\times$  0.303,  $\pm$ SD 2.58  $\times$  0.116), distance of the nerve ring from the anterior extremity 0.249-0.261 (mean 0.215,  $\pm$ SD 0.092).

Male (n=5): the body (length and maximum width) 49.3-51.3  $\times$  0.49-0.91 (mean 50.0  $\times$  0.66,  $\pm$ SD 0.93  $\times$  0.21); the body width at the inner circle of papillae 0.095-0.164 (mean 0.131,  $\pm$ SD 0.032); the body width at the outer circle of papillae 0.153-0.181 (mean 0.167,  $\pm$ SD 0.012), the body width at the nerve ring 0.212-0.45 (mean 0.374,  $\pm$ SD 0.094); length of the buccal cavity 0.187-0.191 (mean 0.189,  $\pm$ SD 0.002); the length and maximum width of the oesophagus 12.5-15  $\times$  0.347-0.367 (mean 13.6  $\times$  0.352,  $\pm$ SD 0.96  $\times$  0.009), distance of the nerve ring from the anterior extremity 0.245-0.249 (mean 0.246,  $\pm$ SD 0.002).

#### *Philometra ovata* (Zeder, 1803)

Three adult nematodes (females with eggs in uteruses) of this species were recorded in roach (3♂♂ 27.1-29.3 cm long) from Lake Raduńskie Dolne (Table 4). They were confirmed in the body cavity of fish during the summer period of 2006.

#### *Raphidascaris acus* (Bloch, 1779), L3

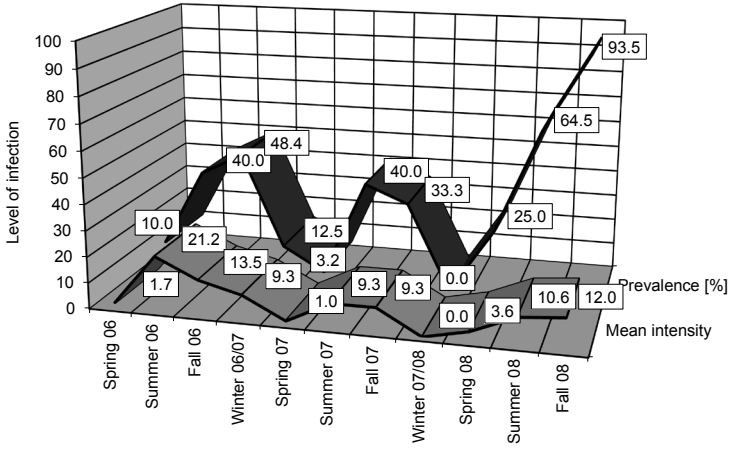
Ten parasites of this species were recorded in five females (16.7-18.5 cm long) and six parasites in six males of roach (15.6-17.5 cm long) from Lake Żarnowieckie, while in Lake Raduńskie Dolne there were 16 nematodes in five females (16.5-18.2 cm long) and 20 in seven males of roach (14.5-19.9 cm long) (Tables 3, 4).

The parasites were collected in the spring (6 specimens in Lake Żarnowieckie and 14 in Lake Raduńskie Dolne) and summer periods (10 and 22, respectively).

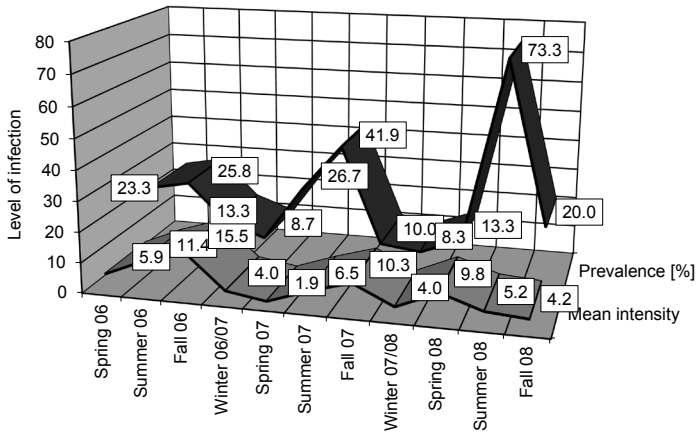
Nematodes were found mainly in the intestinal walls (48 specimens), and rarely in the gallbladder (3 specimens) of the fish.

#### Nematoda, n.det., L3

Three specimens of this parasite were found in two females (22.4 and 22.9 cm long) and four nematodes in one male of roach (21.5 cm long) from Lake Żarnowieckie (Table 3). These were dead nematodes (encysted, irregular cysts) found in the intestine wall of the fish.



**Fig. 61.** Seasonal occurrence of *Acanthocephalus lucii* in European perch from Lake Raduńskie Dolne.



**Fig. 62.** Seasonal occurrence of *Acanthocephalus lucii* in European perch from Lake Żarnowieckie.



## 5. Acanthocephala

### *Acanthocephalus lucii* (Müller, 1766)

Acanthocephalans were found in European perch from both lakes and in roach from Lake Raduńskie Dolne. European perch was the typical host, but the highest infection parameters were recorded in the fish from Lake Raduńskie Dolne (Tables 4-6).

Usually, the highest level of infection was found in European perch caught in fall and summer in Lake Raduńskie Dolne and in summer in Lake Żarnowieckie ( $p < 0.0001$ ) for prevalence, (Figs 61, 62). The infected roach were found in the summer of 2006 (1 specimen) and fall of 2007 (5 specimens).

The most strongly infected fish in Lake Żarnowieckie and Lake Raduńskie Dolne were those from the fish length class of 18.1-21 cm (Figs 63, 64). The four infected roach females from Lake Raduńskie Dolne belonged to the length class of 18.9-23.5 cm.

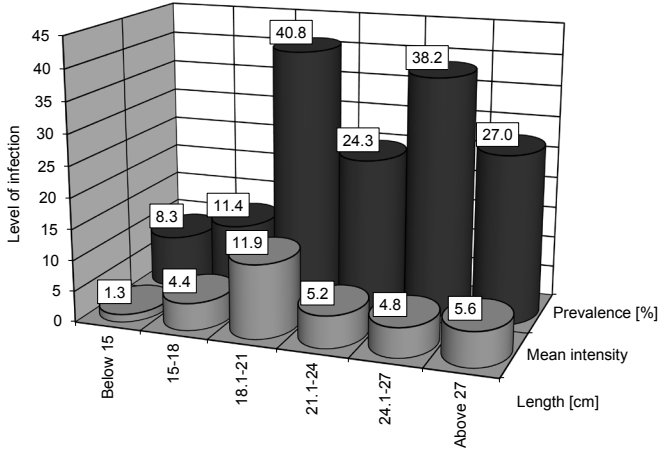
Among 1805 collected acanthocephalans, females dominated (866 and 328 specimens respectively in Lakes Raduńskie Dolne and Żarnowieckie) as compared to males (424 and 187 specimens, respectively). In roach only male acanthocephalans were found. All females in European perch had eggs developed.

*A. lucii* was found mainly in the intestine (1754 specimens) and less frequently in the pyloric caeca (51). Females were located mainly in the posterior part of the intestine. With the intensity higher than fifteen acanthocephalans in the intestine, other parasites were not recorded in European perch. Additionally, when even single acanthocephalans were found in the pyloric caeca of European perch, no other helminths were recorded.

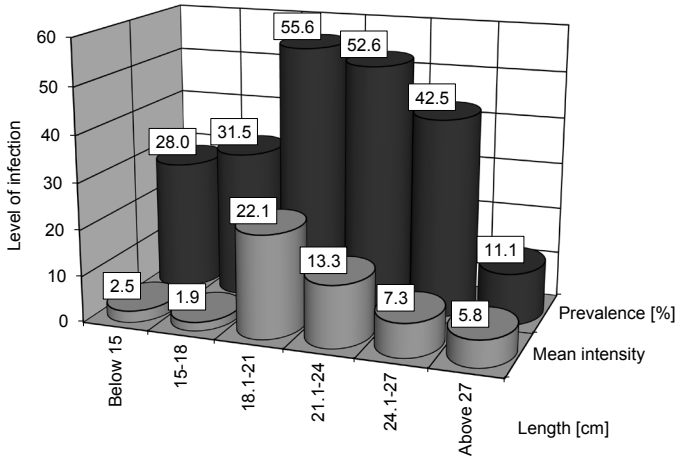
The infection of female and male European perch in Lake Raduńskie Dolne was respectively as follows: prevalence 48.4%, mean intensity 11.1 and 20.7%, 12.4, while in Lake Żarnowieckie the infection level was 28.7%, 7.1 and 19.6%, 5.3, respectively.

### *Echinorhynchus gadi* Müller, 1776

Two specimens of this species of acanthocephalans (♂♂) were found in one European perch (♂, 27.2 cm long) from Lake Żarnowieckie (Table 5). They were collected from the intestine of the fish in the summer period of 2008.



**Fig. 63.** Correlation between the occurrence of *Acanthocephalus lucii* and the European perch length in Lake Żarnowieckie.



**Fig. 64.** Correlation between the occurrence of *Acanthocephalus lucii* and the European perch length in Lake Raduńskie Dolne.

*Pomphorhynchus laevis* (Müller, 1776)

In fall 2007, two specimens of these acanthocephalans (male and female with eggs) were recorded in the intestine of European perch (♂, 25.9 cm long) from Lake Żarnowieckie (Table 5).

## 6. Nematomorpha

*Gordionus* sp.

This nematomorph was found in the intestine of the European perch (♀, 26.1 cm long) in Lake Raduńskie Dolne (Table 6) in summer 2006. It was an adult, live specimen.

Since the nematomorph was recorded in the European perch for the first time, its morphometric data are presented in this paper (in mm). Measurements were taken after the specimen had been fixed and cleared.

## Description (Fig. 65):

male: the body color bright brown, anterior tip rounded, white; length and maximum width of the body  $252.2 \times 0.47$ ; bilobed posterior end; cloacal opening oval, circumcloacal spines absent; precloacal bristle fields and postcloacal spines present; length and width of lobes  $0.48 \times 0.26$  and  $0.47 \times 0.26$ ; distance of the cloacal opening from the posterior extremity 0.62; polygonal areoles.

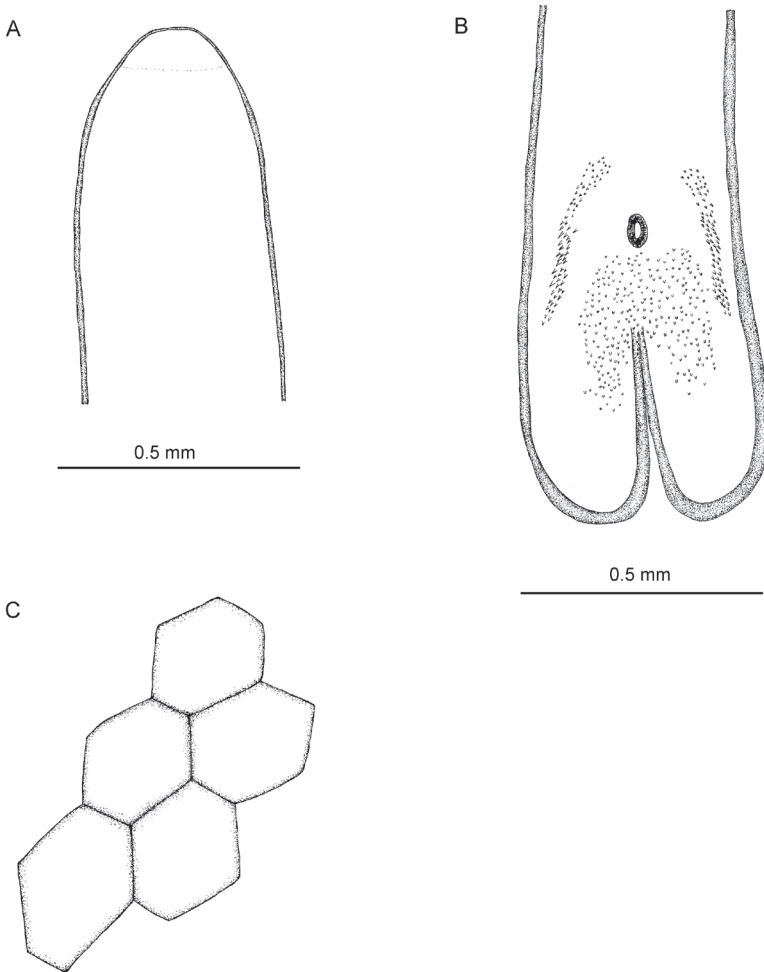
## 7. Copepoda

*Achtheres percarum*, chalimus IV, adult

These copepods were found in European perch from both lakes. Slightly higher infection rates were recorded in the fish from Lake Żarnowieckie (Tables 5, 6).

The collected material included mature females and males (44 specimens from Lake Żarnowieckie and 25 from Lake Raduńskie Dolne), and specimens in stage IV chalimus (8 and 6 specimens respectively). The females were represented by forms with the developed egg sacs (85 specimens from Lake Żarnowieckie and 53 from Lake Raduńskie Dolne) and forms without egg sacs (64 and 28 respectively).

The males attached to the females were larger ( $n=20$ , in mm, 0.035-0.038, mean 0.037,  $\pm$ SD 0.001) than free specimens that were attached to the fish gills ( $n=20$ , 0.027-0.029, mean 0.028,  $\pm$ SD 0.001). Twenty-seven males were attached to females, and 42 to the gills.



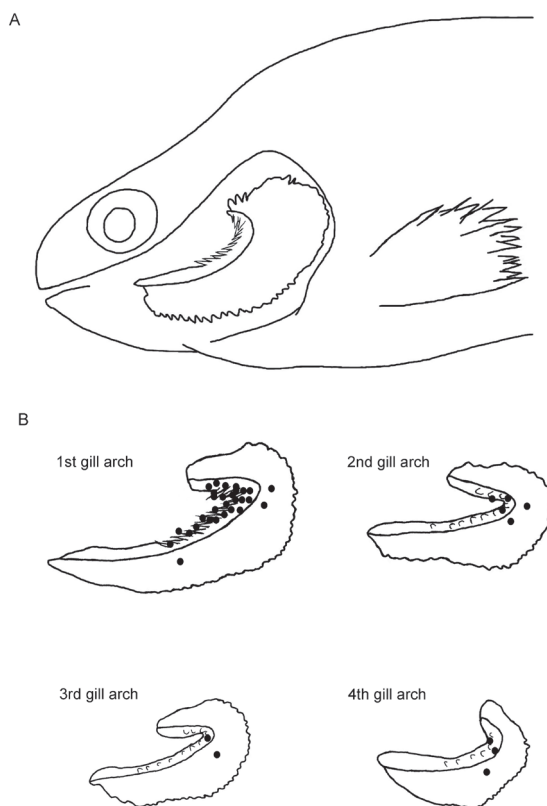
**Fig. 65.** *Gordionus* sp. (male) from the intestine of European perch from Lake Raduńskie Dolne; A: anterior tip, B: posterior end, C: areoles.

The parasites were located mainly on the gills, and less frequently in the oral cavity (4 specimens on the palette and two on the lips) of the European perch. The distribution of *A. percarum* on the gills was typical. Most of the parasites were located on the first gill, while the copepods preferred the gill rakers or the bony gill arch to the gill filaments (Table 7, Fig. 66).

**Table 7**

Distribution by the abundance of *Achtheres percarum* on the gills of European perch from the investigated lakes.

Gills	Gill rakers / arches	Gill filaments	Total
1 <sup>st</sup> gill arch	199	27	226
2 <sup>nd</sup> gill arch	20	17	37
3 <sup>rd</sup> gill arch	11	8	19
4 <sup>th</sup> gill arch	15	10	25
Total	245	62	307



**Fig. 66.** Placement of the gills in the European perch gill cavity (A). Distribution of *Achtheres percarum* (indicated by dots) on European perch gills (B).

The prevalence in European perch from Lake Raduńskie Dolne was the highest in summer ( $p < 0.0001$ ), while from Lake Żarnowieckie in spring and fall (and in one instance, the highest prevalence was recorded in summer) ( $p < 0.05$ ). Mean intensity was low and ranged between 1.0 and 4.3 in Lake Żarnowieckie and 1.0-2.8 in Lake Raduńskie Dolne (Figs 67, 68).

The level of infection depended on the size of the European perch and increased as the length increased ( $p < 0.01$  for prevalence in Lake Żarnowieckie,  $p < 0.05$  for prevalence and  $p < 0.01$  for mean intensity in Lake Raduńskie Dolne (Figs 69, 70).

In Lake Żarnowieckie, infection was higher in males (prevalence 41.1%, mean intensity 2.9) than in females of the European perch (14.9%, 2.3). However, in Lake Raduńskie Dolne, infection rates in females and males were 19.6%, 1.8 and 25.0%, 1.7, respectively.

In winter 2006 (December, Lake Żarnowieckie) four copepods found had Sessilida (Peritrichia, Ciliophora) epibionts on their pereons.

#### *Caligus lacustris* Streenstrup et Lütken, 1861

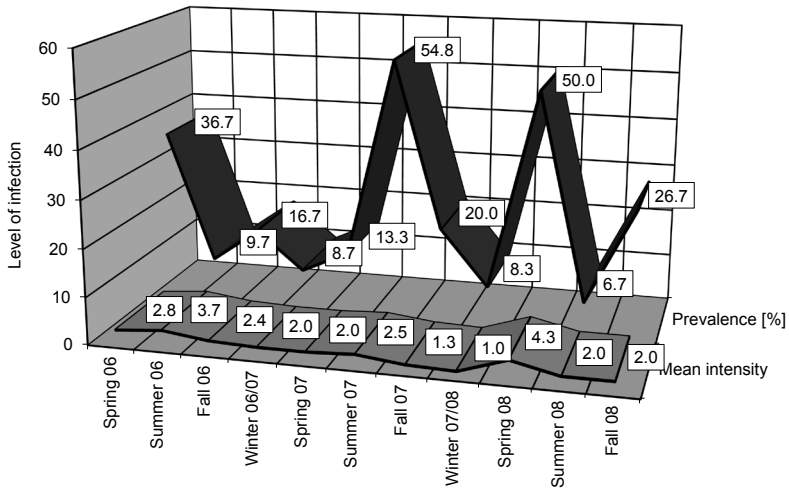
Three of these copepods (two females with egg sacs and one without) were found on two female roach individuals (15.9 and 19.4 cm long) and one male roach (22.0 cm long). The parasites were found only in Lake Raduńskie Dolne (Table 4) in the summer 2006 and 2008. They were collected from the surface of the fish.

#### *Ergasilus briani* Markewitsch, 1932

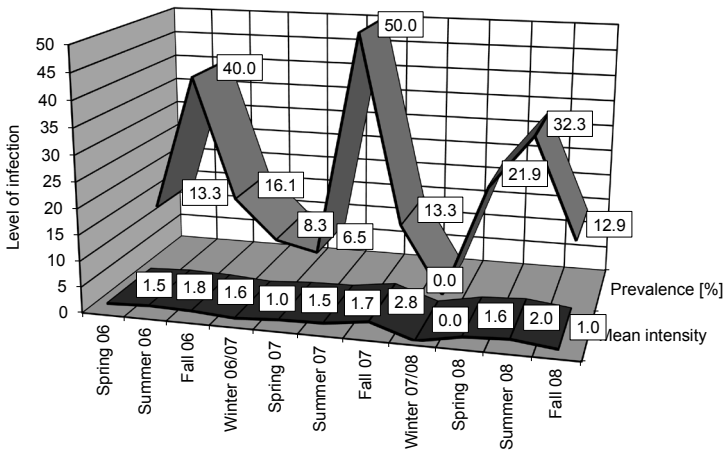
This parasite was confirmed only on roach from Lake Raduńskie Dolne (Table 4). On six infected females (25.1-28.9 cm long) and 11 infected males of roach (23.3-27.9 cm long), respectively 12 and 30 copepods were found. They were collected in spring 2007 and their egg sacs were already developed. The parasites had settled the areas between the gill filaments on the second (23 specimens), first (12) and third (7) gill arches.

#### *Ergasilus sieboldi* Nordmann, 1832

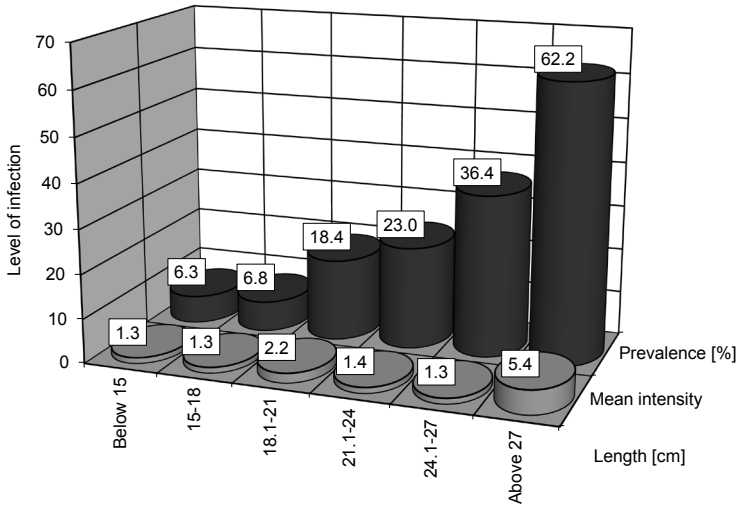
These copepods were found on both European perch and roach from both lakes (Tables 3-6). In Lake Żarnowieckie, five females (17.9-21.3 cm long) and seven males of European perch (15.2-22.9 cm long), and eight females (23.4-27.5 cm long) and one male of roach (23.4 cm long) were infected. The number of parasites found on them was 52 and 26, and 40 and 5, respectively. In Lake Raduńskie Dolne, six females (15.3-18.9 cm long) and eight males (14.2-



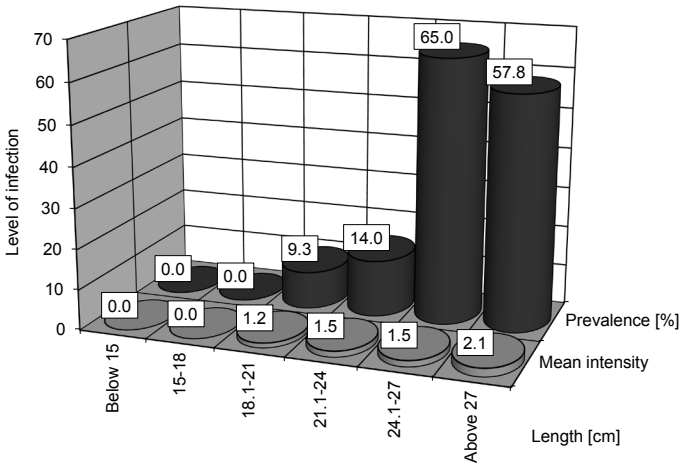
**Fig. 67.** Seasonal occurrence of *Achtheres percarum* in European perch from Lake Żarnowieckie.



**Fig. 68.** Seasonal occurrence of *Achtheres percarum* in European perch from Lake Raduńskie Dolne.



**Fig. 69.** Correlation between the occurrence of *Achtheres percarum* and the European perch length in Lake Żarnowieckie.



**Fig. 70.** Correlation between the occurrence of *Achtheres percarum* and the European perch length in Lake Raduńskie Dolne.



18.3 cm long) of European perch and four female (24.4-27.3 cm long) and 11 male roach (23.9-27.7 cm long) were confirmed to have 18, 30, 19, and 20 copepods, respectively.

The copepods were found in spring (53 in Lake Żarnowieckie and 40 in Lake Raduńskie Dolne), in summer (20 and 31 respectively), and in fall (50 and 16 respectively). Moreover, in spring 50 parasites with egg sacs were recorded and 43 specimens without egg sacs, in summer 15 and 36, and in fall 56 and 10, respectively.

The parasites settled on the gill filaments of the second (45 specimens), first (119), third (28), and fourth (18) gill arches.

## 8. Branchiura

### *Argulus foliaceus* (Linnaeus, 1758)

This parasite was confirmed on roach and European perch from both lakes, but the roach from Lake Raduńskie Dolne had higher infection parameters (Tables 3-6).

In Lake Żarnowieckie, 6, 12, 13 and 10 fish lice were found on six females (11.2-23.9 cm long) and eight males (17.2-22.9 cm long) of European perch, and on ten females (12.9-32.0 cm long) and nine males (13.9-21.9 cm long) of roach, respectively.

In Lake Raduńskie Dolne, 9, 24, 28 and 37 parasites were found on five females (13.9-17.3 cm long) and 12 males of European perch (14.4-28.3 cm long), and on 13 female roach (21.3-27.6 cm long) and 14 male roach (17.3-15.1 cm long).

The parasites were found in spring (2 specimens in Lake Żarnowieckie and 10 in Lake Raduńskie Dolne), in summer (30 and 64, respectively), and in fall (9 and 24, respectively).

Females dominated among the collected parasite specimens with only two males collected in summer 2007 from roach from Lake Raduńskie Dolne.

The parasites settled mainly on the skin (87 specimens), gills (36) and in the oral cavity (16).

## 9. Hirudinea

### *Caspiobdella fadejevi* (Epshtein, 1961)

Three of these leeches were confirmed on two roach (♀ 23.1 cm long and ♂ 26.2 cm long) from Lake Żarnowieckie (Table 3). The fish were caught in spring 2006, and the parasites were collected from the fish gills.

*Piscicola geometra* (Linnaeus, 1761)

These leeches were found on European perch and roach from both lakes, but higher infection parameters were recorded for the roach from Lake Żarnowieckie (Tables 3-6).

In Lake Żarnowieckie, 6, 17, 35 and 12 parasites were recorded on six females (15.8-27.3 cm long) and 13 males of European perch (15.0-23.4 cm long), and on 22 female roach (15.9-29.6 cm long) and 10 male roach (16.7-26.1 cm long), respectively.

In Lake Raduńskie Dolne, 8, 10, 7 and 14 leeches were found on eight females (18.1-23.8 cm long) and nine males of European perch (15.1-19.9 cm long) and on six female roach (22.4-31.2 cm long) and ten male roach (18.7-27.3 cm long), respectively.

The parasites were found in spring (34 specimens in Lake Żarnowieckie and 23 in Lake Raduńskie Dolne), in summer (13 and 9, respectively) and fall (14, 7), and also in winter (9 in Lake Żarnowieckie).

These parasites settled mainly on the skin (85 specimens, including 10 on fins), the mouth cavity (8), and gills (6).

## 10. Bivalvia

*Anodonta anatina* (Linnaeus, 1758), glochidium

The larvae of this mollusk occurred on European perch and roach from both lakes (Tables 3-6).

In Lake Żarnowieckie, 9, 43 and 15 glochidia were found on nine female European perch (14.1-17.2 cm long), and on 32 female roach (13.2-15.2 cm long) and 10 male roach (15.7-16.6 cm long), respectively. In turn, in Lake Raduńskie Dolne, 11, 12, 7 and 11 glochidia were found on six females (13.4-17.1 cm long) and seven males of European perch (13.9-15.6 cm long), and on two female roach (14.1 and 16.3 cm long) and six male roach (15.3-17.7 cm long), respectively.

The parasites were recorded in spring (24 specimens in Lake Żarnowieckie and 27 in Lake Raduńskie Dolne) and in summer (43 and 14 specimens, respectively).

Most of the glochidia were collected from the caudal fins (49 specimens), fewer from the pectoral fins (38), and the least from the pelvic fins (21).

The structure of the hook (shape and teeth) and the size of the parasites collected from free-living fish corresponded to the structure of glochidia obtained experimentally. The length and the height of the glochidia (in mm) collected from the fish from Lakes Żarnowieckie and Raduńskie Dolne were, at  $n=20$ ,  $0.308-0.353 \times 0.351-0.368$  (mean  $0.337 \times 0.360$ ,  $\pm$ SD  $0.021 \times 0.007$ )

and, at  $n=15$ ,  $0.310-0.357 \times 0.349-0.369$  (mean  $0.344 \times 0.356$ ,  $\pm$ SD  $0.019 \times 0.008$ ), respectively.

*Pseudanodonta complanata* (Rossmässler, 1835) glochidium

In Lake Raduńskie Dolne, three and five glochidia of this species were found on three females (13.8-16.2 cm long) and four males of European perch (14.0-15.8 cm long) (Table 6). They were confirmed in the spring of 2007 (7 specimens) and the spring of 2008 (1 specimen). The parasites were collected from the pectoral (6 specimens) and anal fins (2).

The structure of the hook (shape and teeth) and the dimensions (length  $\times$  height) of the shell ( $n=5$ , in mm,  $0.306-0.360 \times 0.300-0.302$ , mean  $0.341 \times 0.301$ ,  $\pm$ SD  $0.024 \times 0.001$ ) of the parasites collected from free-living fish corresponded to the morphology of glochidia obtained experimentally.

*Unio* sp., glochidium

These parasites were found on the fish from Lake Raduńskie Dolne (Table 6). There were 18 and 25 glochidia on 15 females (15.4-24.1 cm long) and eight males of European perch (14.3-21.4 cm long).

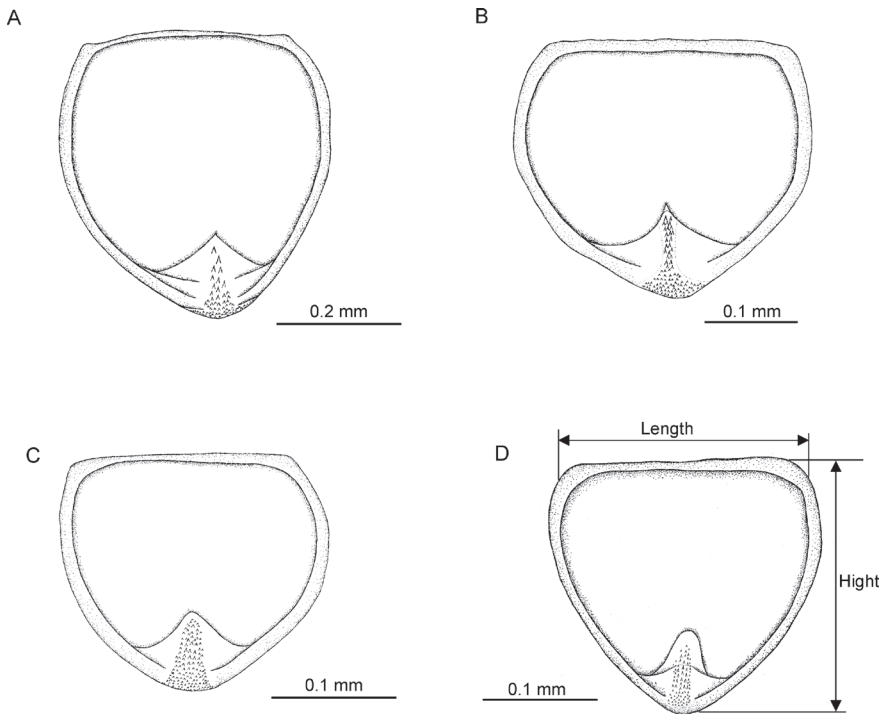
Most of the glochidia were located on fins – 16 on pectoral, four on pelvic and four on anal fins. The remaining specimens were collected from gill filaments; these parasites preferred the second (8 specimens) and the first (7 specimens) gill arch as compared to the third (2) and the fourth gill arch (2).

The sizes (length  $\times$  height, in mm) of the collected glochidia ( $n=12$ ) were  $0.210-0.229 \times 0.159-0.208$  (mean  $0.219 \times 0.195$ ,  $\pm$ SD  $0.008 \times 0.024$ ). Because of the overlapping size ranges and sometimes the structure of the hooks, the collected glochidia were identified only to the genus. Identification was also difficult for specimens with closed shells since it was difficult to see the structure of the long hook.

***Description of glochidia obtained from experimental infection of fish***

*Anodonta anatina* (Fig. 71A)

Measurements were taken on preserved specimens ( $n=30$ , in mm): the long, sharp hook was covered with widely spaced large teeth and tightly packed small teeth, with the latter at the base of the hook, and the former covering the thin upper and middle strip of the hook. The valves of the shells were generally longitudinally elongated, measuring in length  $\times$  height  $0.335-0.380 \times 0.336-0.402$  (mean  $0.363 \times 0.380$ ,  $\pm$ SD  $0.017 \times 0.026$ ). The shells were yellow-beige in color.



**Fig. 71.** Glochidia of *Anodonta anatina* (A), *Pseudanodonta complanata* (B), *Unio pictorum* (C) and *Unio tumidus* (D) obtained from experimental infection of fish.

All of the Crucian carp used in the experiment were infected, while one European perch did not survive and was not infected. The mean intensity of Crucian carp infection was 19.6 with the intensity range of 14-26, while the corresponding figures for European perch were 17.0 and 2-33. Most (91.6%) of the glochidia were covered by epidermal cysts. The glochidia were confirmed only on the fins, with 40 on pectoral, 49 on pelvic and 77 on anal fins.

*Pseudanodonta complanata* (Fig. 71B)

Measurements were taken on preserved specimens (n=30, in mm): the long, sharp hook was covered with thickly distributed large and small teeth, with the latter mainly near the base of the hook (at the shell apex), while the large teeth covered the thin upper and middle strips of the hook. The shell valves were distinctly transversely elongated, measuring in length × height 0.302-0.362 ×

0.287-0.329 (mean  $0.340 \times 0.302$ ,  $\pm$  SD  $0.023 \times 0.017$ ). The shells were yellow-beige in color.

All of the Crucian carp used in the experiment were infected, while one European perch did not survive and was not infected. The mean intensity of Crucian carp infection was 7.0 with the range of 3-9, while the corresponding figures for the European perch were 3.8 and 3-4. Most (88.0%) of the glochidia were covered with epidermal cysts. The glochidia were confirmed only on the fins, with 22 on pectoral, 20 on pelvic and 8 on anal fins.

#### *Unio pictorum* (Fig. 71C)

Measurements were taken on preserved specimens (n=30, in mm): the long hook was covered with small and very small, thickly packed teeth. The larger teeth formed from three to four longitudinal rows, with the larger teeth at the middle of the tooth-covered surface. There are from one to four rows of very fine teeth along the sides of the large teeth, and the base of the hook is covered with many small teeth. The shell valves were transversely elongated measuring (length  $\times$  height)  $0.212-0.226 \times 0.168-0.204$  (mean  $0.216 \times 0.196$ ,  $\pm$  SD  $0.020 \times 0.006$ ). The shells were white with some transparent areas.

All of the Crucian carp and European perch used in the experiment were infected. The mean intensity of Crucian carp infection was 69.2 specimens with the range of 1-138, while the corresponding figures for European perch were – 24.5 and 2-73. Most (94.6%) of the glochidia were covered with epidermal cysts. The glochidia were occurring mainly on fins, with 211 on pectoral, 100 on pelvic and 133 on anal fins. Only 12 glochidia were collected from the gills (the first gill arch), but those were not encysted specimens.

#### *Unio tumidus* (Fig. 71D)

Measurements were taken on preserved specimens (n=30, in mm): the long hook was generally thinner than in *U. pictorum*. It was covered with small and very small tightly packed teeth that occupied a wide space of the hook, but which was, however, slightly narrower than in *U. pictorum*. The larger teeth formed three longitudinal rows, with the larger teeth located in the middle of the tooth-covered surface. Along the side of the large teeth, there were from one to four rows of very fine teeth; however, the concentration of small teeth at the base of the hook was smaller than in *U. pictorum*. Valves of the shell transversally elongated, the size (length  $\times$  height)  $0.201-0.234 \times 0.183-0.212$  (mean  $0.218 \times 0.200$ ,  $\pm$ SD  $0.011 \times 0.010$ ). The shells were white with some transparent areas.

All of the Crucian carp and European perch used in the experiment were infected. The mean intensity of Crucian carp infection was 60.0 specimens with

the range of 3-115, while the corresponding values for perch were 45.8 and 4-63. Most (87.2%) of the glochidia were covered with epidermal cysts. The glochidia were primarily recorded on fins; specifically 233 specimens on pectoral, 89 on pelvic and 161 on anal fins. Eight glochidia were found on the gills (the first and second gill arches), but just one was encysted.

### ***Condition of fish***

The condition coefficient was higher in European perch, both infected and uninfected, from Lake Żarnowieckie than in the fish from Lake Raduńskie Dolne. The uninfected European perch had higher condition coefficients than the infected fish. However, the roach (most were infected) from Lake Raduńskie Dolne had a higher condition factor (Table 8).

### ***Description of roach parasites in Lake Żarnowieckie***

The overall infection of roach by all parasites was with the prevalence of 95.1%, mean intensity of 31.7 and the intensity range of 1-115. A total of 9,194 parasites were collected from roach and included parasites from Monogenea, Digenea, Cestoda, Nematoda, Copepoda, Branchiura, Hirudinea and Bivalvia (Table 3).

The parasite fauna of roach was dominated by Monogenea (8 species), Digenea (6 species and *Diplostomum* spp.), while the remaining groups included from one to three species (Table 9). Digeneans dominated quantitatively (89.9%) compared to other parasite groups (Fig. 72).

The dominant species, i.e. those recorded in more than 50% of the examined fish, included the digeneans *Diplostomum* spp. and *T. clavata*. Common species included the monogenean *D. crucifer*, the digenean *P. cuticola* and the tapeworm *P. scolecina*, the leech *P. geometra* and the glochidia *A. anatina*. Rare species included the digeneans *B. polymorphus* and *D. gavium* and the fish louse *A. foliaceus*. The remaining parasites were classified as sporadic (Table 3).

The most numerous species on roach were autogenic species (17 taxa). These included all of the monogeneans, two species of digeneans, one species of cestode, one species of nematode, and all of the crustacean, leeches and mollusk species. Allogenic parasite species were represented exclusively by larvae and included four identified species of digeneans, the metacercariae *Diplostomum* spp., the tapeworm *P. scolecina* and the nematode *D. numidica* (Table 10). The allogenic species dominated (90.8%) as compared to autogenic species (Fig. 73).

**Table 8**

Values of the Fulton condition coefficient of the fish analyzed from Lakes Żarnowieckie and Raduńskie Dolne.

	Lake Żarnowieckie		Lake Raduńskie Dolne	
	European perch	Roach	European perch	Roach
Infected fish	1.1944	1.2979	1.1554	1.4334
Uninfected fish	1.2981	-*	1.1958	-**

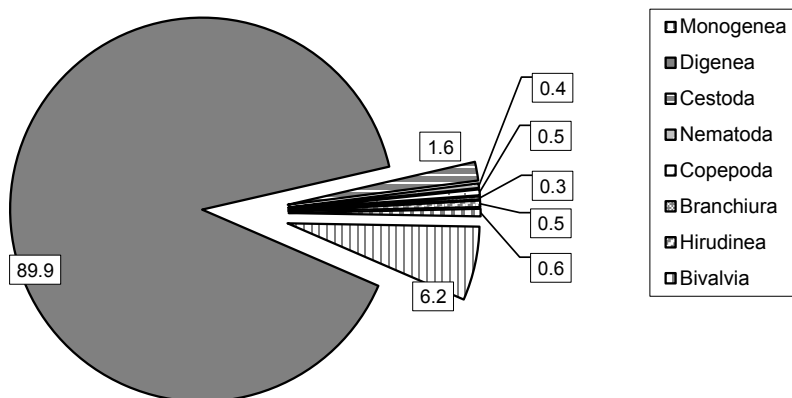
\*: only fifteen roach were uninfected, \*\*: all fish were infected

**Table 9**

Taxonomic structure (species/genus in terms of abundance) of the parasite fauna of roach and European perch from Lakes Żarnowieckie and Raduńskie Dolne.

Taxa / lake / fish	Lake Żarnowieckie		Lake Raduńskie Dolne		Total
	Roach	European perch	Roach	European perch	
Monogenea	8	0	5	0	8
	8		5		
Digenea	7	8	13	10*	18
	12		18		
Cestoda	2	3	3	3	7
	5		6		
Nematoda	3	3	2	6	11
	6		8		
Acanthocephala	0	3	1	1	3
	3		1		
Nematomorpha	0	0	0	1	1
	0		1		
Copepoda	1	2	3	2	4
	2		4		
Branchiura	1	1	1	1	1
	1		1		
Hirudinea	2	1	1	1	2
	2		1		
Bivalvia	1	1	1	3	3
	1		3		
Total	25	22	30	28	58
	40		48		

\*: larval and adult stages of *Rhipidocotyle campanula* were confirmed in European perch from Lake Raduńskie Dolne



**Fig. 72.** Quantitative contribution (%) of representatives of particular taxa in roach from Lake Żarnowieckie.

**Table 10**

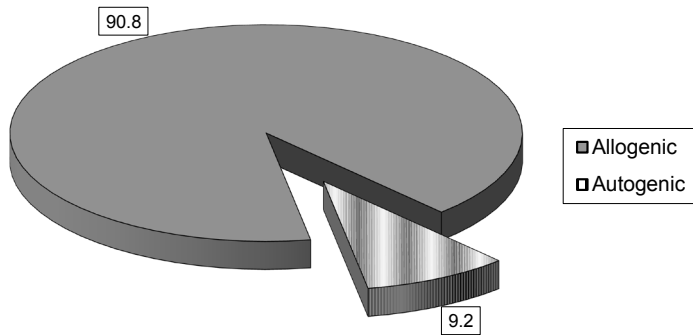
List of allogenic and autogenic parasites found in the roach from Lake Żarnowieckie.

Allogenic	Autogenic
<i>Diplostomum gaviium</i> , met.	<i>Dactylogyrus crucifer</i>
<i>Diplostomum</i> spp., met.	<i>Dactylogyrus fallax</i>
<i>Ichthyocotylurus platycephalus</i> , met.	<i>Dactylogyrus nanus</i>
<i>Posthodiplostomum cuticola</i> , met.	<i>Dactylogyrus similis</i>
<i>Tyloodelphys clavata</i> , met.	<i>Dactylogyrus sphyrna</i>
<i>Paradilepis scolecina</i> , pl.	<i>Dactylogyrus wunderi</i>
<i>Desmidocercella numidica</i> , L3	<i>Diplozoon paradoxum</i>
	<i>Paradiplozoon homoion homoion</i>
	<i>Bucephalus polymorphus</i> , met.
	<i>Sphaerostomum bramae</i>
	<i>Caryophyllaeides fennica</i> *
	<i>Raphidascaris acus</i> , L3
	<i>Ergasilus sieboldi</i>
	<i>Argulus foliaceus</i>
	<i>Caspiobdella fadejevi</i>
	<i>Piscicola geometra</i>
	<i>Anodonta anatina</i> , gl.

gl.: glochidium, L3: the third stage larva, met.: metacercaria, pl.: plerocercus,

\*: it was assumed that, similarly to other Caryophyllidea (Bauer 1987, Pojmańska and Cielecka 2001), Oligochaeta are the intermediate hosts. Unidentified larval Nematoda were not included in the list





**Fig. 73.** Quantitative contribution (%) of allogenic and autogenic parasites in roach from Lake Żarnowieckie.

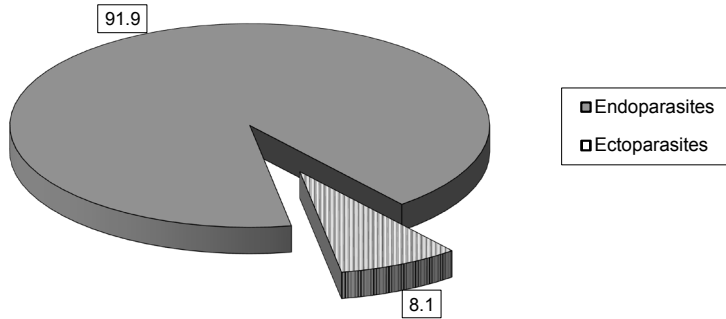
**Table 11**

Taxonomic structure (species/genus in terms of abundance) divided into ectoparasites and endoparasites in roach and European perch from Lakes Żarnowieckie and Raduńskie Dolne.

Parasite	Lake Żarnowieckie		Lake Raduńskie Dolne		Total
	Roach	European perch	Roach	European perch	
Ectoparasites	13	5	11	7	18
	14		14		
Endoparasites	12	17	19	21	40
	26		34		

Among the parasites collected from the roach inhabiting Lake Żarnowieckie, 13 were ectoparasites and 12 were endoparasites (Table 11); however, endoparasites quantitatively dominated over ectoparasites by 91.9% (Fig. 74).

Adult stage species of parasites were recorded more frequently (14 species) than parasites in larval stages (11 species), such as metacercariae, plerocercus, L3 larval nematodes, or glochidia (Table 12). However, specimens in larval



**Fig. 74.** Quantitative contribution (%) of ectoparasites and endoparasites in roach from Lake Żarnowieckie.

**Table 12**

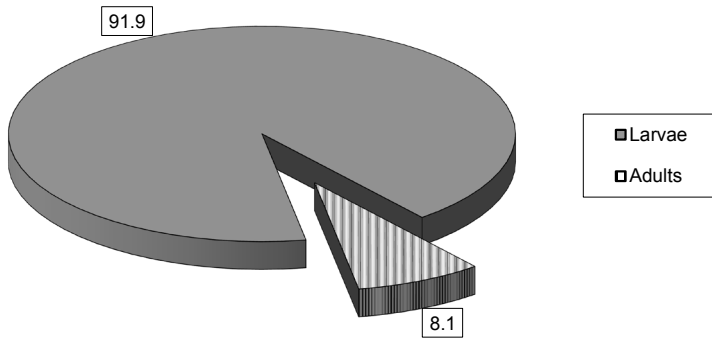
Taxonomic structure (species/genus in terms of abundance) divided into parasites in larval and adult stages in roach and European perch from Lakes Żarnowieckie and Raduńskie Dolne.

Parasite	Lake Żarnowieckie		Lake Raduńskie Dolne		Total
	Roach	European perch	Roach	European perch	
Larvae	11	11	13	17	27
	18		24		
Adults	14	12	17	13	33
	23		26		

Larval and adult stages of *Achtheres percarum* were confirmed in European perch from both lakes. Larval and adult stages of *Rhipidocotyle campanula* were confirmed in European perch from Lake Raduńskie Dolne

stages dominated quantitatively by 91.9% in comparison to those in adult stages (Fig. 75).

Most of the roach parasites (13 species) were from species with a wide host range (polyxenic), while those with a narrow host range (oligoxenic) were represented by just eight species (monogeneans, *D. gavium*, the tapeworm



**Fig. 75.** Quantitative contribution (%) of parasites in larval and adult stages in roach from Lake Żarnowieckie.

*P. scolecina*), and only one was monoxenic (the monogenean *D. similis*) (Table 13).

Thirteen species of parasites had life cycles that occurred on or in a single host species, including monogeneans, copepods, fish lice, leeches and mollusk. Nine (*B. polymorphus*, *D. gaviium*, *Diplostomum* spp., *I. platycephalus*, *P. cuticola*, *T. clavata*, *P. scolecina*, *D. numidica*, *R. acus*) of the parasites with complex life cycles used roach as the intermediate host, while two (*C. fennica*, *S. bramae*) – as the definitive host. The specification, however, does not include a dead, unidentified nematodes.

Among the sampled roach, there were six identified species of digeneans, *Diplostomum* spp. and the nematode *R. acus*, which use mollusks in their life cycles, two parasites use crustaceans (the tapeworm *P. scolecina*, the nematode *R. acus*) and two other groups of invertebrates, annelids and insects (the tapeworm *C. fennica* and the nematode *R. acus*) (Table 14). Also in this case, parasites with mollusks in their life cycles dominated quantitatively (97.9%) (Fig. 76).

**Table 13**

The list of collected parasites including their host specificity ranges (for fish) according to various authors (Bauer 1987, Moravec 1994, Pojmańska and Cielecka 2001, Niewiadomska 2003, Grabda-Kazubska and Okulewicz 2006, Dzika 2008).

S/N	Parasite / fish Lake	European perch		Roach		M/O/P
		Ż	RD	Ż	RD	
MONOGENEA						
1.	<i>Dactylogyrus crucifer</i>			+	+	O (roach)
2.	<i>Dactylogyrus fallax</i>			+		O (chub)
3.	<i>Dactylogyrus nanus</i>			+	+	O (roach)
4.	<i>Dactylogyrus similis</i>			+	+	M (roach)
5.	<i>Dactylogyrus sphyrna</i>			+		O (freshwater bream)
6.	<i>Dactylogyrus wunderi</i>			+		O (freshwater bream)
7.	<i>Diplozoon paradoxum</i>			+	+	P (freshwater bream)
8.	<i>Paradiplozoon homoion homoion</i>			+	+	O (roach)
DIGENEA						
9.	<i>Apatemon gracilis</i> , met.	+	+			O (European perch)
10.	<i>Azygia lucii</i>	+	+			P (northern pike)
11.	<i>Bucephalus polymorphus</i> , met.			+	+	P (Cyprinidae)
12.	<i>Bunodera luciopercae</i>	+	+			O (predatory fish)
13.	<i>Diplostomum gavium</i> , met.			+	+	O (roach, rudd, ruffe)
14.	<i>Diplostomum</i> spp., met.	+	+	+	+	-
15.	<i>Ichthyocotylurus platycephalus</i> , met.	+	+	+	+	P
16.	<i>Ichthyocotylurus pileatus</i> , met.	+	+		+	P
17.	<i>Ichthyocotylurus variegatus</i> , met.	+	+			P*
18.	<i>Paleorchis incognitus</i>				+	O (chub, ide, white bream, roach, rudd)
19.	<i>Paracoenogonimus ovatus</i> , met.				+	P
20.	<i>Phyllodistomum folium</i>		+			P
21.	<i>Posthodiplostomum cuticola</i> , met.			+	+	P (Cyprinidae)
22.	<i>Rhipidocotyle campanula</i> , met., ad.		+		+	P (met.: Cyprinidae, ad.: predatory fish)
23.	<i>Sphaerostomum bramae</i>			+	+	P (Cyprinidae)
24.	<i>Sphaerostomum globiporum</i>				+	P
25.	<i>Tylodelphys clavata</i> , met.	+	+	+	+	P (roach, European perch)
26.	Digenea, n.det., met.				+	-
CESTODA						
27.	<i>Caryophyllaeides fennica</i>			+	+	P (roach)
28.	<i>Caryophylleus laticeps</i>				+	P (freshwater bream)
29.	<i>Eubothrium crassum</i> , pl.	+				O (European perch)
30.	<i>Paradiilepis scolecina</i> , pl.			+	+	O (Cyprinidae)
31.	<i>Proteocephalus percae</i>	+	+			P (European perch)
32.	<i>Proteocephalus</i> spp.**		+			-
33.	<i>Triaenophorus nodulosus</i> , pl.	+	+			O (European perch)

S/N	Parasite / fish	European perch		Roach		M/O/P
		Ž	RD	Ž	RD	
NEMATODA						
34.	<i>Anguillicoloides crassus</i> , L3		+			P (ruffe)
35.	<i>Anisakis simplex</i> , L3	+				P (Clupeidae, Gadidae)
36.	<i>Camallanus lacustris</i>	+	+			P (Percidae, European perch)
37.	<i>Camallanus truncatus</i>	+				P (Percidae, pike-perch)
38.	<i>Contracaecum</i> sp., L3		+			-
39.	<i>Cosmocephalus obvelatus</i> , L3		+			P
40.	<i>Desmidocercella numidia</i> , L3		+	+		P
41.	<i>Eustrongylides excisus</i> , L4		+			P
42.	<i>Philometra ovata</i>				+	P (Cyprinidae)
43.	<i>Raphidascaris acus</i> , L3			+	+	P (Cyprinidae)
44.	Nematoda, n.det., L3				+	-
ACANTHOCEPHALA						
45.	<i>Acanthocephalus lucii</i>	+	+		+	P (predatory fish)
46.	<i>Echinorhynchus gadi</i>	+				P (Gadidae)
47.	<i>Pomphorhynchus laevis</i>	+				P
NEMATOMORPHA						
48.	<i>Gordionus</i> sp.		+			-
COPEPODA						
49.	<i>Achtheres percarum</i> , ch.IV, ad.	+	+			M (European perch)
50.	<i>Caligus lacustris</i>				+	P
51.	<i>Ergasilus briani</i>				+	P (Cyprinidae)
52.	<i>Ergasilus sieboldi</i>	+	+	+	+	P (Cyprinidae, Esocidae, Salmonidae, Percidae, )
BRANCHIURA						
53.	<i>Argulus foliaceus</i>	+	+	+	+	P
HIRUDINEA						
54.	<i>Caspiobdella fadejevi</i>			+		P (Cyprinidae)
55.	<i>Piscicola geometra</i>	+	+	+	+	P
BIVALVIA						
56.	<i>Anodonta anatina</i> , gl.	+	+	+	+	P***
57.	<i>Pseudanodonta complanata</i> , gl.		+			P***
58.	<i>Unio</i> sp., gl.		+			-***

Ž: Lake Żarnowieckie, RD: Lake Raduńskie Dolne, ad.: adult, ch.IV: the fourth chalmus, gl.: glochidium, L3,4: the third/fourth stage larva, met.: metacercaria, pl.: plerocerkoid, plerocercus; M: monoxenic parasite, O: oligoxenic parasite, P: polyxenic parasite, the main host given in parentheses for some parasite species, all known hosts (fish) given for *Diplostomum gavium* and *Paleorchis incognitus*, -: host specificity not determined (dead parasites or only identified down to the genus), \*: the host list requires verification (Niewiadomska 2003), \*\*: juvenile specimens, \*\*\*: since glochidia are rarely identified, the host list requires verification

### ***Description of roach parasites in Lake Raduńskie Dolne***

The overall infection of roach by all parasites was with the prevalence of 100.0%, mean intensity of 46.6 and the intensity range of 1-374. A total of 14,129 parasites from Monogenea, Digenea, Cestoda, Nematoda,

Table 14

Invertebrate species identified as hosts for the collected parasites according to various authors (Bauer 1987, Moravec 1994, Pojmańska and Cielecka 2001, Niewiadomska 2003, Grabda-Kazubaska and Okulewicz 2006).

Parasite	Mollusca	Arthropoda, Crustacea	Other
<i>Apatemon gracilis</i>	+		
<i>Azygia lucii</i>	+		
<i>Bucephalus polymorphus</i>	+		
<i>Bunodera luciopercae</i>	+	+	
<i>Diplostomum gaviium</i>	+*		
<i>Diplostomum</i> spp.	+		
<i>Ichthyocotylurus pileatus</i>	+*		
<i>Ichthyocotylurus platycephalus</i>	+		
<i>Ichthyocotylurus variegatus</i>	+		
<i>Paleorchis incognitus</i>			-
<i>Paracoenogonimus ovatus</i>	+		
<i>Phyllodistomum folium</i>	+		Odonata ( <i>Libellula quadrimaculata</i> )
<i>Posthodiplostomum cuticola</i>	+		
<i>Rhipidocotyle campanula</i>	+		
<i>Sphaerostomum bramae</i>	+		
<i>Sphaerostomum globiporum</i>	+		Hirudinea ( <i>Herpobdella</i> )
<i>Tylodelphys clavata</i>	+		
<i>Caryophyllaeides fennica</i>			Oligochaeta**
<i>Caryophylleus laticeps</i>			Oligochaeta
<i>Eubothrium crassum</i>		+	
<i>Paradilepis scolecina</i>		+	
<i>Proteocephalus percae</i>		+	
<i>Proteocephalus</i> spp.		+	
<i>Triaenophorus nodulosus</i>		+	
<i>Anguillicoloides crassus</i>	+	+	Aquatic Insecta (Odonata, Megaloptera, Trichoptera)***
<i>Anisakis simplex</i>		+	
<i>Camallanus lacustris</i>		+	
<i>Camallanus truncatus</i>		+	
<i>Contraecum</i> sp.		+	Odonata****
<i>Cosmocephalus obvelatus</i>		+	
<i>Desmidocercella numidica</i>			-
<i>Eustrongylides excisus</i>			Oligochaeta
<i>Philometra ovata</i>		+	
<i>Raphidascaaris acus</i>	+	+	Oligochaeta, aquatic Diptera (Chironomidae, Ceratopogonidae)
<i>Acanthocephalus lucii</i>		+	
<i>Echinorhynchus gadi</i>		+	
<i>Pomphorhynchus laevis</i>		+	
<i>Gordionus</i> sp.			Myriapoda and Insecta*****

\*: it was assumed that, similarly to other *Diplostomum* and *Ichthyocotylurus* (Niewiadomska 2003), the intermediate hosts are representatives of Gastropoda,

\*\* : it was assumed that, similarly to other Caryophyllidae (Bauer 1987, Pojmańska and Cielecka 2001), the intermediate hosts are Oligochaeta,

\*\*\*: as paratenic hosts (Moravec 1996),

\*\*\*\*: in some species of the genus *Contraecum*, odonates occur as paratenic hosts (Moravec 1996),

\*\*\*\*\*: host unknown for most species (Schmidt-Rhaesa 1997),

-: host unknown. Unidentified digeneans and nematodes not taken into consideration in the table

Acanthocephala, Copepoda, Branchiura, Hirudinea, and Bivalvia were collected (Table 4).

Digenea dominated in the parasite fauna of the roach (13 taxa, including *Diplostomum* spp. and one unidentified taxon). Monogenea were less numerously represented – by just five species. The cestodes, nematodes and copepods were represented by two or three species each, while all other groups were represented by single species (Table 9). Digeneans dominated quantitatively (94.0%) in comparison to all other parasite groups (Fig. 77).

The dominant species were the digeneans *Diplostomum* spp. and *T. clavata*. Common species included the monogeneans *D. crucifer*, the digenean *D. gavium*, *P. cuticola* and *R. campanula*, and the cestode *P. scolecina*. Rare species included the monogeneans *D. similis* and *D. paradoxum*, the digeneans *B. polymorphus*, *P. ovatus*, and *S. globiporum*, the tapeworm *C. fennica*, the nematode *R. acus*, the copepods *E. briani* and *E. sieboldi*, the fish louse *A. foliaceus*, the leech *P. geometra*. The remaining parasites were classified as sporadic (Table 4).

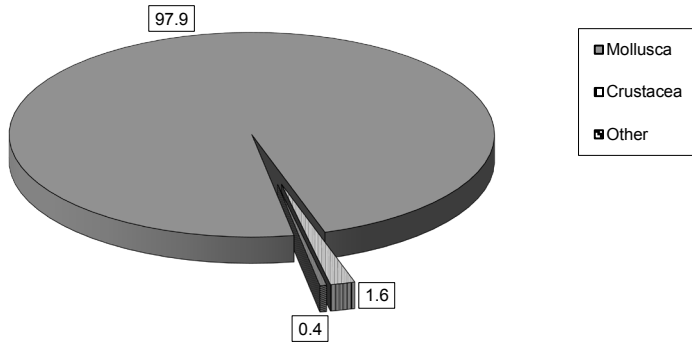
Roach parasites were dominated by autogenic species (20 taxa). They included all of the monogeneans, four digeneans species, two species each of tapeworms and nematodes, and one species each of acanthocephalans, copepods, fish lice, leeches and mollusks. Allogenic species were represented exclusively by larvae, which included six species of digeneans, the *Diplostomum* spp. and one species of a tapeworm (Table 15), but quantitatively, allogenic species (86.7%) dominated as compared to autogenic species (Fig. 78).

More of the parasite infections in roach from Lake Raduńskie Dolne were by endoparasites (19 taxa) than ectoparasites (11) (Table 11); endoparasites dominated quantitatively (95.4%) compared to ectoparasites (Fig. 79).

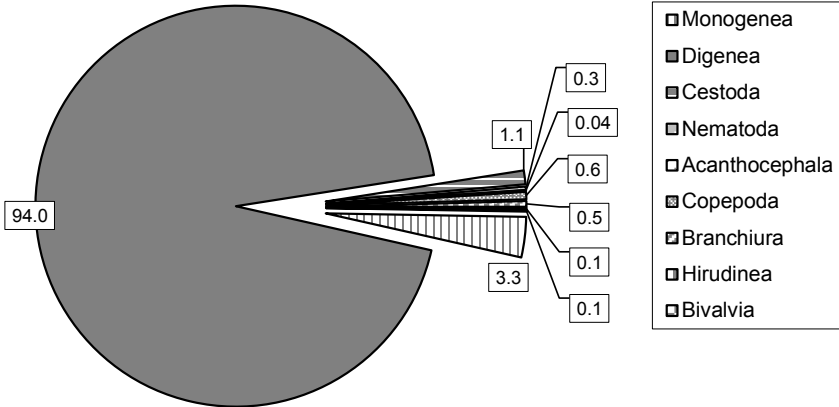
Parasites in adult stages (17 species) were more common than those in larval stages (13) (Table 12). However, in terms of a developmental stage, parasites in larval stages (94.9%) dominated quantitatively upon those in adult stages (Fig. 80).

Most of the roach parasites (21 species) were polyxenic, six were oligoxenic species (monogeneans – *D. crucifer*, *D. nanus*, *P. homoion homoion*; digeneans – *D. gavium*, *P. incognitus*; tapeworm – *P. scolecina*). The monogenean *D. similis*, which is specific to roach, was the only monoxenic parasite (Table 13).

Eleven parasite species had simple life cycles and did not change their hosts; these included monogeneans, crustaceans, leeches and mollusks. For eleven parasite species with complex life cycles, roach was the intermediate host (*B. polymorphus*, *D. gavium*, *Diplostomum* spp., *I. pileatus*, *I. platycephalus*, *P. ovatus*, *P. cuticola*, *R. campanula*, *T. clavata*, *P. scolecina*, *R. acus*), and for



**Fig. 76.** Quantitative contribution (%) of parasites, including species whose development depends on intermediate hosts, such as mollusks, crustaceans, or other groups of invertebrates in roach from Lake Żarnowieckie.



**Fig. 77.** Quantitative contribution (%) of representatives of particular taxa in roach from Lake Raduńskie Dolne.



**Table 15**

List of allogenic and autogenic parasites found in the roach from Lake Raduńskie Dolne.

Allogenic	Autogenic
<i>Diplostomum gavium</i> , met.	<i>Dactylogyrus crucifer</i>
<i>Diplostomum</i> spp., met.	<i>Dactylogyrus nanus</i>
<i>Ichthyocotylurus pileatus</i> , met.	<i>Dactylogyrus similis</i>
<i>Ichthyocotylurus platycephalus</i> , met.	<i>Diplozoon paradoxum</i>
<i>Paracoenogonimus ovatus</i> , met.	<i>Paradiplozoon homoion homoion</i>
<i>Posthodiplostomum cuticola</i> , met.	<i>Bucephalus polymorphus</i> , met.
<i>Tylodelphys clavata</i> , met.	<i>Rhipidocotyle campanula</i> , met.
<i>Paradilepis scolecina</i> , pl.	<i>Sphaerostomum bramae</i>
	<i>Sphaerostomum globiporum</i>
	<i>Caryophyllaeides fennica</i> *
	<i>Caryophylleus laticeps</i>
	<i>Philometra ovata</i>
	<i>Raphidascaris acus</i> , L3
	<i>Acanthocephalus lucii</i>
	<i>Caligus lacustris</i>
	<i>Ergasilus briani</i>
	<i>Ergasilus sieboldi</i>
	<i>Argulus foliaceus</i>
	<i>Piscicola geometra</i>
	<i>Anodonta anatina</i> , gl.

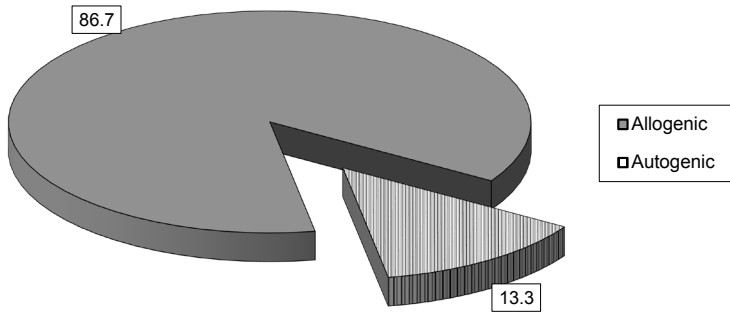
gl.: glochidium, L3: the third stage larva, met.: metacercaria, pl.: plerocercus, \*: it was assumed that, similarly to other Caryophyllidea (Bauer 1987, Pojmańska and Cielecka 2001), the intermediate hosts are Oligochaeta. Unidentified larval Digenea were not included in the list. The digenean *Paleorchis incognitus* was not included since the life cycle is not known

seven species (*P. incognitus*, *S. bramae*, *S. globiporum*, *C. fennica*, *C. laticeps*, *P. ovata*, *Acanthocephalus lucii*), it was the definitive host. The specification, however, does not include a dead, unidentified metacercariae.

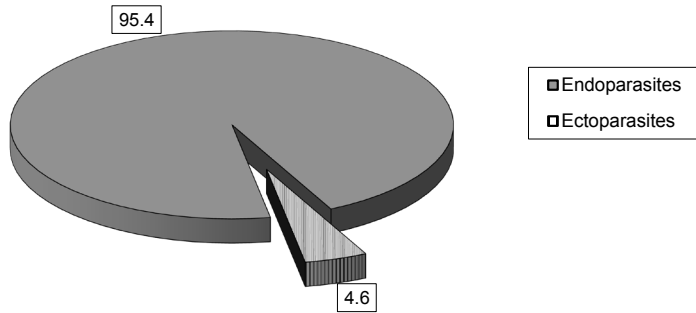
Additionally, life cycles of ten digeneans species, *Diplostomum* spp., and the nematode *R. acus*, have include parasites in stages occurring in mollusks, four in crustaceans (1 Cestoda, 2 Nematoda and 1 Acanthocephala), and four in other groups of invertebrates - annelids and insects (1 Digenea, 2 Cestoda, 1 Nematoda) (Table 14). Also in this instance, the quantitative dominants (97.9%) were parasites for which mollusks are intermediate hosts (Fig. 81).

### **Description of European perch parasites in Lake Żarnowieckie**

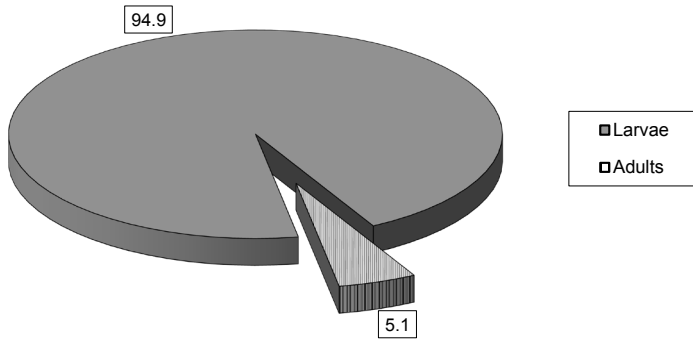
The overall prevalence and intensity (including all parasites) of European perch parasite infection was 63.2%, 89.7, and 1-201, respectively. In total, 17,395 parasites from Digenea, Cestoda, Nematoda, Acanthocephala, Copepoda, Branchiura, Hirudinea and Bivalvia were recorded (Table 5).



**Fig. 78.** Quantitative contribution (%) of allogenic and autogenic parasites in roach from Lake Raduńskie Dolne.



**Fig. 79.** Quantitative contribution (%) of ectoparasites and endoparasites in roach from Lake Raduńskie Dolne.

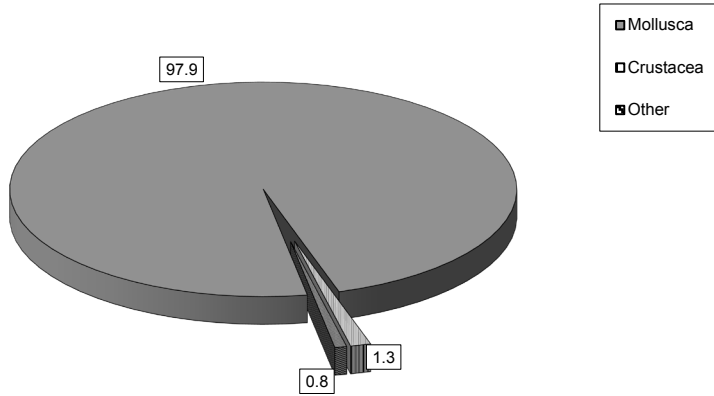


**Fig. 80.** Quantitative contribution (%) of parasites in larval and adult stages in roach from Lake Raduńskie Dolne.

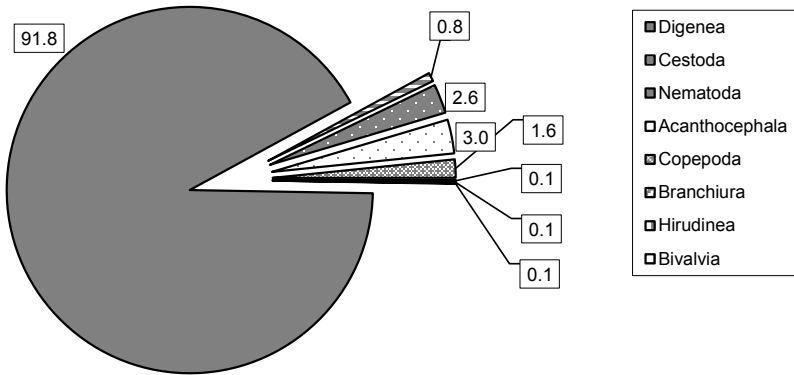
Taking into account the richness of species, the dominant parasites of the European perch from Lake Żarnowieckie were Digenea (7 species and *Diplostomum* spp.). Tapeworms, nematodes and acanthocephalans were represented by three species each, copepods by two species, and the remaining groups were represented by one species each (Table 9). Digeneans were also the quantitative dominants (91.8%) in comparison to other groups of parasites (Fig. 82).

Among the collected parasites, the digeneans were the common species: *A. gracilis*, *B. luciopercae*, *Diplostomum* spp., *T. clavata*; the tapeworm *T. nodulosus*; the nematode *Camallanus lacustris*; the acanthocephalan *Acanthocephalus lucii*; and the copepod *A. percarum*. The digeneans were rare species: *I. pileatus*, *I. platycephalus*, and *I. variegatus*; the tapeworm *P. percae*, the fish louse *A. foliaceus*; the leech *P. geometra*, while the remaining groups of parasites were classified as sporadic.

The most diverse in and on European perch were autogenic species (15 taxa). They included two species of digeneans, three species of tapeworms, two of nematodes, three of acanthocephalans, all of the crustaceans, leeches and mollusks. Allogenic species were represented by Digenea in the metacercaria stage (5 species and *Diplostomum* spp.), and nematode *A. simplex* (Table 16). The allogenic dominated (88.7%) in comparison to autogenic ones (Fig. 83).



**Fig. 81.** Quantitative contribution (%) of parasites, including species whose development depends on intermediate hosts, such as mollusks, crustaceans, or other groups of invertebrates in roach from Lake Raduńskie Dolne.



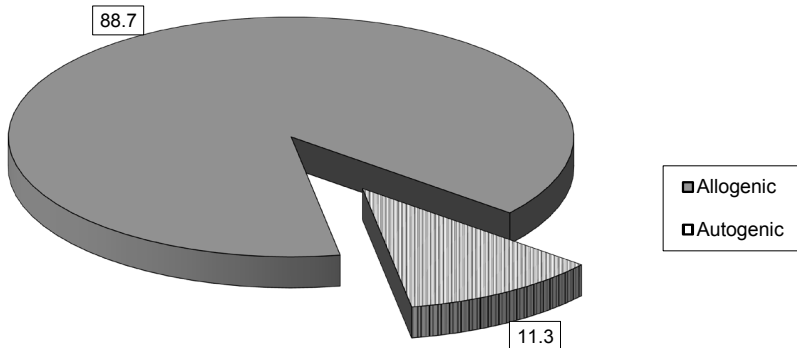
**Fig. 82.** Quantitative contribution (%) of representatives of particular taxa in European perch from Lake Żarnowieckie.

**Table 16**

List of allogenic and autogenic parasites found in the European perch from Lake Żarnowieckie.

Allogenic	Autogenic
<i>Apatemon gracilis</i> , met.	<i>Azygia lucii</i>
<i>Diplostomum</i> spp., met.	<i>Bunodera luciopercae</i>
<i>Ichthyocotylurus platycephalus</i> , met.	<i>Eubothrium crassum</i> , pl.
<i>Ichthyocotylurus pileatus</i> , met.	<i>Proteocephalus percae</i>
<i>Ichthyocotylurus variegatus</i> , met.	<i>Triaenophorus nodulosus</i> , pl.
<i>Tylodelphys clavata</i> , met.	<i>Camallanus lacustris</i>
<i>Anisakis simplex</i> , L3	<i>Camallanus truncatus</i>
	<i>Acanthocephalus lucii</i>
	<i>Echinorhynchus gadi</i>
	<i>Pomphorhynchus laevis</i>
	<i>Achtheres percarum</i> , ch.IV, ad.
	<i>Ergasilus sieboldi</i>
	<i>Argulus foliaceus</i>
	<i>Piscicola geometra</i>
	<i>Anodonta anatina</i> , gl.

ad.: adult, ch.IV: the fourth chalimus, gl.: glochidium, L3: the third stage larva, met.: metacercaria, pl.: plerocercoid



**Fig. 83.** Quantitative contribution (%) of allogenic and autogenic parasites in European perch from Lake Żarnowieckie.

Seventeen species of endoparasites and five of ectoparasites were found in and on European perch. Parasites in adult stages were more common than those in larval stages (Tables 11, 12). The quantitative dominants were also the endoparasites (98.1%) in comparison to ectoparasites (Fig. 84). However, in terms of a developmental stage, larvae dominated (89.5%) in comparison to adult parasites (Fig. 85).

Polyxenic parasites were also dominant in the European perch from Lake Żarnowieckie (16 taxa) compared to oligoxenic (*A. gracilis*, *B. luciopercae*, *E. crassum*, *T. nodulosus*) and monoxenic ones (*A. percarum* – specific to European perch) (Table 13).

Only five parasite species collected from the European perch from Lake Żarnowieckie had a life cycle without changing a host; these were represented by copepods, fish lice *A. foliaceus*, the leeches *P. geometra* and glochidia of *A. anatina*. The European perch was the intermediate host for nine parasites (*A. gracilis*, *Diplostomum* spp, *I. pileatus*, *I. platycephalus*, *I. variegatus*, *T. clavata*, *E. crassus*, *T. nodulosus*, *A. simplex*), and the definitive host for eight species (*Azygia lucii*, *B. luciopercae*, *P. percae*, *Camallanus lacustris*, *C. truncatus*, *Acanthocephalus lucii*, *E. gadi*, *P. laevis*).

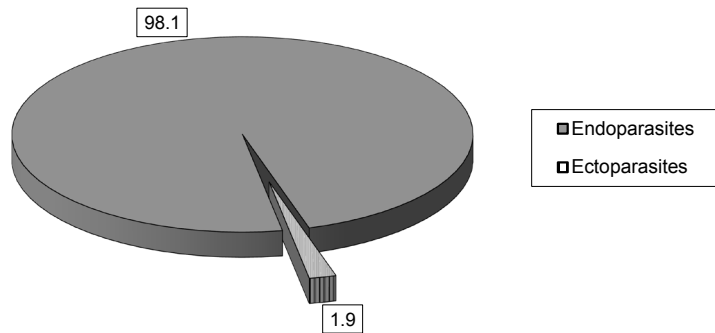
Seven species of digeneans and *Diplostomum* spp. occurred in mollusks during their life cycles, while ten taxa (1 Digenea, 3 Cestoda, 3 Nematoda, 3 Acanthocephala) occurred in crustaceans. The European perch parasites occurring in Lake Żarnowieckie did not occur in groups of invertebrates other than mollusks and crustaceans (Table 14). The quantitative dominants were parasites that spent one life stage in mollusks (Fig. 86).

### ***Description of European perch parasites in Lake Raduńskie Dolne***

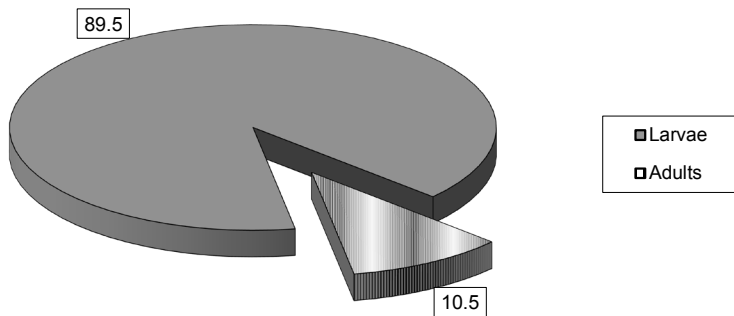
The overall level of parasitic infection of European perch from Lake Raduńskie Dolne was 85.7%, 80.3, and 1-394. A total of 20,626 parasites were collected, including representatives of Digenea, Cestoda, Nematoda, Acanthocephala, Nematomorpha, Copepoda, Branchiura, Hirudinea and Bivalvia (Table 6).

The qualitative composition of European perch parasites was dominated by Digenea (10 taxa including *Diplostomum* spp. and *R. campanula* in both adult and metacercaria stages). Nematoda were represented by six species, while Cestoda and Bivalvia – by three taxa each, Copepoda – by two species, and the remaining groups by one species each (Table 9). Digeneans also dominated quantitatively (81.6%) compared to other groups of parasites (Fig. 87).

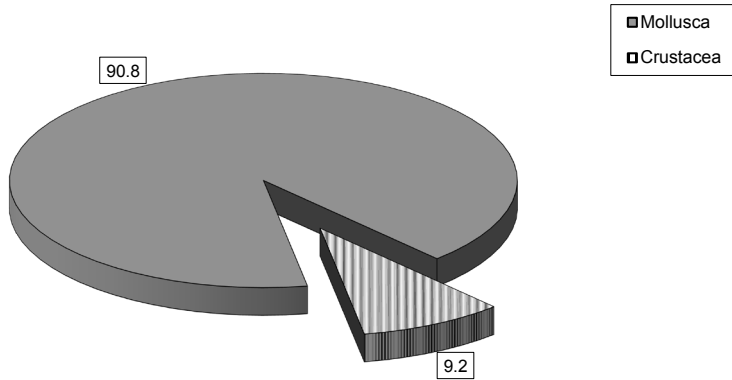
The dominant parasites in European perch from Lake Raduńskie Dolne were the digeneans *Diplostomum* spp. and *T. clavata*. Common species were the



**Fig. 84.** Quantitative contribution (%) of ectoparasites and endoparasites in European perch from Lake Żarnowieckie.



**Fig. 85.** Quantitative contribution (%) of parasites in larval and adult stages in European perch from Lake Żarnowieckie.



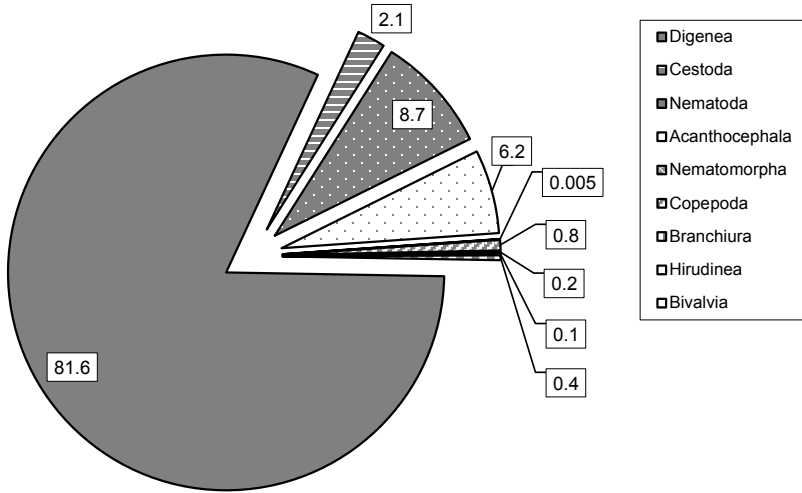
**Fig. 86.** Quantitative contribution (%) of parasites, including species whose development depends on intermediate hosts, such as mollusks and crustaceans in European perch from Lake Żarnowieckie.

digeneans *A. gracilis*, *B. lucioperace* and *I. variegatus*, as well as the tapeworms *P. percae* and *T. nodulosus*, the nematode *Camallanus lacustris*, the acanthocephalan *Acanthocephalus lucii* and the copepod *A. percarum*. Rare species were the digeneans *Azygia lucii*, *I. pileatus*, *I. platycephalus* and *R. campanula* (ad.), the copepod *E. sieboldi*, the fish louse *A. foliaceus*, the leech *P. geometra* and the glochidia of *A. anatina* and *Unio* sp. The remaining parasites were classified as sporadic (Table 6).

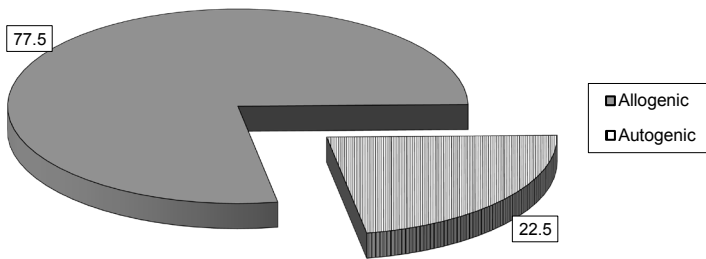
The European perch from Lake Raduńskie Dolne were dominated by autogenic species (17 taxa) that included four species of digeneans, two of tapeworms and *Proteocephalus* spp., two nematode species and all of the acanthocephalans, arthropods, leeches and mollusks. The allogenic species were represented primarily by larvae including five identified species of digeneans, *Diplostomum* spp. and four species of nematodes (Table 17). The allogenic category of species also included the nematomorph *Gordionus* sp. Quantitatively, allogenic species dominated (77.5%) as compared with autogenic species (Fig. 88).

Endoparasites (21 taxa) dominated in the European perch from Lake Raduńskie Dolne in comparison to ectoparasites, which were represented by





**Fig. 87.** Quantitative contribution (%) of representatives of particular taxa in European perch from Lake Raduńskie Dolne.



**Fig. 88.** Quantitative contribution (%) of allogenic and autogenic parasites in European perch from Lake Raduńskie Dolne.

seven taxa. Taxa of parasites in larval stages (17) were being found more frequently than those in adult stages (13) (Tables 11, 12). The quantitative dominants were also endoparasites (98.6%) compared to ectoparasites (Fig. 89), and parasites in larval stages (79.7%) compared to those in adult stages (Fig. 90).

Most of the European perch's parasites were polyxenic (18 species). Oligoxenic parasites were represented by the digeneans *A. gracilis* and *B. luciopercae*, and the tapeworm *T. nodulosus*. Only one parasite recorded was monoxenic - it was the copepod *A. percaum* specific to European perch (Table 13).

Only seven taxa of parasites represented by crustaceans, leeches and fish lice did not change a host during their life cycles. The European perch was the intermediate host for 13 parasites with complex life cycles (*A. gracilis*, *Diplostomum* spp., *I. pileatus*, *I. platycephalus*, *I. variegatus*, *R. campanula* met., *T. clavata*, *T. nodulosus*, *A. crassus*, *Contracaecum* sp., *C. obvelatus*, *D. numidica*, *E. excisus*), and the definitive host for eight parasites (*Azygia lucii*, *B. luciopercae*, *P. folium*, *R. campanula* ad., *P. percae*, *Proteocephalus* spp., *Camallanus lacustris*, *Acanthocephalus lucii*); the list does not include nematomorph.

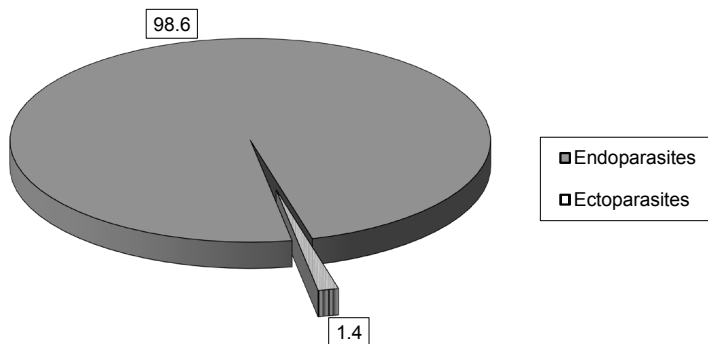
Additionally, mollusks occur in the life cycles of ten parasitic taxa (9 Digenea, nematode *A. crassus*), crustaceans occur in nine taxa (1 Digenea, 3 Cestoda, 4 Nematoda, 1 Acanthocephala), and other groups of invertebrates (annelids and insects) in five taxa (1 Digenea, 3 Nematoda, 1 Nematomorpha) (Table 14). Again, in comparison to other groups, the quantitative dominants (79.5%) were parasites that used mollusks in their life cycles (Fig. 91).

### ***Using the ecological indices of the community structure of parasitic Metazoa in the fish from the two lakes***

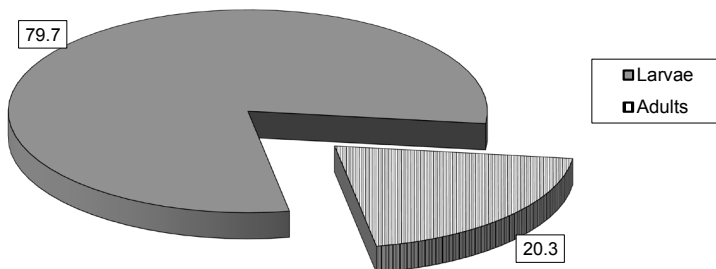
Greater metazoan parasite species richness was observed among the fish from Lake Raduńskie Dolne, where 48 parasite taxa were recorded; 30 associated with roach and 28 with European perch. There were 40 taxa in Lake Żarnowieckie, including 25 associated with roach and 22 with European perch (Tables 9, 18-21).

In Lake Raduńskie Dolne, there were more species of Digenea, Cestoda, Nematoda, Nematomorpha, Copepoda and Bivalvia, while in Lake Żarnowieckie, there were more Monogenea, Acanthocephala and Hirudinea. The remaining taxon (Branchiura) was represented by one species.

Greater species richness in the communities of all metazoan parasites was observed in the fish from Lake Raduńskie Dolne, where the highest values of



**Fig. 89.** Quantitative contribution (%) of ectoparasites and endoparasites in European perch from Lake Raduńskie Dolne.



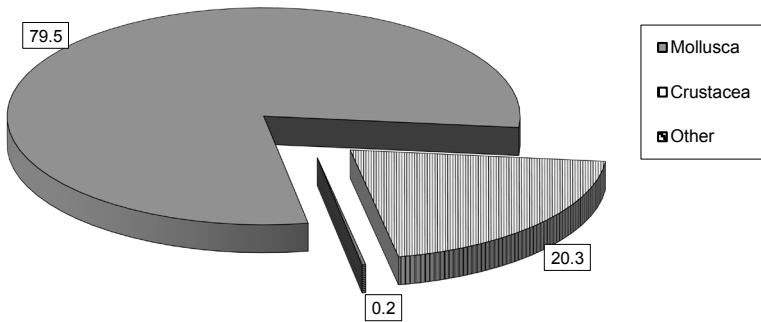
**Fig. 90.** Quantitative contribution (%) of parasites in larval and adult stages in European perch from Lake Raduńskie Dolne.

**Table 17**

List of allogenic and autogenic parasites found in the European perch from Lake Raduńskie Dolne.

Allogenic	Autogenic
<i>Apatemon gracilis</i> , met.	<i>Azygia lucii</i>
<i>Diplostomum</i> spp., met.	<i>Bunodera luciopercae</i>
<i>Ichthyocotylurus pileatus</i> , met.	<i>Phyllodistomum folium</i>
<i>Ichthyocotylurus platycephalus</i> , met.	<i>Rhipidocotyle campanula</i> , met., ad.
<i>Ichthyocotylurus variegatus</i> , met.	<i>Proteocephalus percae</i>
<i>Tyloodelphys clavata</i> , met.	<i>Proteocephalus</i> spp.
<i>Contracaecum</i> sp., L3	<i>Triaenophorus nodulosus</i> , pl.
<i>Desmidocercella numidica</i> , L3	<i>Anguillicoloides crassus</i> , L3
<i>Eustrongylides excisus</i> , L4	<i>Camallanus lacustris</i>
<i>Cosmocephalus obvelatus</i> , L3	<i>Acanthocephalus lucii</i>
<i>Gordionus</i> sp.	<i>Achtheres percarum</i> , ch.IV, ad.
	<i>Ergasilus sieboldi</i>
	<i>Argulus foliaceus</i>
	<i>Piscicola geometra</i>
	<i>Anodonta anatina</i> , gl.
	<i>Pseudanodonta complanata</i> , gl.
	<i>Unio</i> sp., gl.

ad.: adult, ch.IV: the fourth chalimus, gl.: glochidium, L3,4: the third/fourth stage larva, met.: metacercaria, pl.: plerocercoid



**Fig. 91.** Quantitative contribution (%) of parasites, including species whose development depends on intermediate/paratenic hosts such as mollusks, crustaceans, or other groups of invertebrates in European perch from Lake Raduńskie Dolne.

**Table 18**

List of parasites found in the roach and the European perch from Lake Żarnowieckie.

<i>Rutilus rutilus</i>	<i>Perca fluviatilis</i>	Common parasites
<i>Dactylogyrus crucifer</i>	<i>Apatemon gracilis</i> , met.	<i>Diplostomum</i> spp., met.
<i>Dactylogyrus fallax</i>	<i>Azygia lucii</i>	<i>Ichthyocotylurus platycephalus</i> , met.
<i>Dactylogyrus nanus</i>	<i>Bunodera luciopercae</i>	<i>Tylodelphys clavata</i> , met.
<i>Dactylogyrus similis</i>	<i>Ichthyocotylurus pileatus</i> , met.	<i>Ergasilus sieboldi</i>
<i>Dactylogyrus sphyrna</i>	<i>Ichthyocotylurus variegatus</i> , met.	<i>Argulus foliaceus</i>
<i>Dactylogyrus wunderi</i>	<i>Eubothrium crassum</i> , pl.	<i>Piscicola geometra</i>
<i>Diplozoon paradoxum</i>	<i>Proteocephalus percae</i>	<i>Anodonta anatina</i> , gl.
<i>Paradiplozoon homoion homoion</i>	<i>Triaenophorus nodulosus</i> , pl.	
<i>Bucephalus polymorphus</i> , met.	<i>Anisakis simplex</i> , L3	
<i>Diplostomum gavium</i> , met.	<i>Camallanus lacustris</i>	
<i>Posthodiplostomum cuticola</i> , met.	<i>Camallanus truncatus</i>	
<i>Sphaerostomum bramae</i>	<i>Acanthocephalus lucii</i>	
<i>Caryophyllaeides fennica</i>	<i>Echinorhynchus gadi</i>	
<i>Paradilepis scolecina</i> , pl.	<i>Pomphorhynchus laevis</i>	
<i>Raphidascaris acus</i> , L3	<i>Achtheres percarum</i> , ch.IV, ad.	
<i>Desmidocercella numidica</i> , L3		
Nematoda, n.det., L3*		
<i>Caspiobdella fadejevi</i>		

ad.: adult, ch.IV: the fourth chalimus, gl.: glochidium, L3: the third stage larva, met.: metacercaria, pl.: plerocercoid, plerocercus, \*: dead specimens

**Table 19**

List of parasites found in the roach and the European perch from Lake Raduńskie Dolne.

<i>Rutilus rutilus</i>	<i>Perca fluviatilis</i>	Common parasites
<i>Dactylogyrus crucifer</i>	<i>Apatemon gracilis</i> , met.	<i>Diplostomum</i> spp., met.
<i>Dactylogyrus nanus</i>	<i>Azygia lucii</i>	<i>Ichthyocotylurus pileatus</i> , met.
<i>Dactylogyrus similis</i>	<i>Bunodera luciopercae</i>	<i>Ichthyocotylurus platycephalus</i> , met.
<i>Diplozoon paradoxum</i>	<i>Ichthyocotylurus variegatus</i> , met.	<i>Rhipidocotyle campanula</i> , met.
<i>Paradiplozoon homoion homoion</i>	<i>Phyllodistomum folium</i>	<i>Tylodelphys clavata</i> , met.
<i>Bucephalus polymorphus</i> , met.	<i>Rhipidocotyle campanula</i> , ad.	<i>Acanthocephalus lucii</i>
<i>Diplostomum gavium</i> , met.	<i>Proteocephalus percae</i>	<i>Ergasilus sieboldi</i>
<i>Paleorchis incognitus</i>	<i>Proteocephalus</i> spp.**	<i>Argulus foliaceus</i>
<i>Paracoenogonimus ovatus</i> , met.	<i>Triaenophorus nodulosus</i> , pl.	<i>Piscicola geometra</i>
<i>Posthodiplostomum cuticola</i> , met.	<i>Anguillicoloides crassus</i> , L3	<i>Anodonta anatina</i> , gl.
<i>Sphaerostomum bramae</i>	<i>Camallanus lacustris</i>	
<i>Sphaerostomum globiporum</i>	<i>Contraecum</i> sp., L3	
Digenea, n.det., met.*	<i>Desmidocercella numidica</i> , L3	
<i>Caryophyllaeides fennica</i>	<i>Eustrongylides excisus</i> , L4	
<i>Caryophylleus laticeps</i>	<i>Cosmocephalus obvelatus</i> , L3	
<i>Paradilepis scolecina</i> , pl.	<i>Gordionus</i> sp.	
<i>Philometra ovata</i>	<i>Achtheres percarum</i> , ch.IV, ad.	
<i>Raphidascaris acus</i> , L3	<i>Pseudanodonta complanata</i> , gl.	
<i>Caligus lacustris</i>	<i>Unio</i> sp., gl.	
<i>Ergasilus briani</i>		

ad.: adult, ch.IV: the fourth chalimus, gl.: glochidium, L3,4: the third/fourth stage larva, met.: metacercaria, pl.: plerocercoid, plerocercus, \*: dead specimens, \*\*: juvenile specimens

**Table 20**

List of parasites found in the roach from Lakes Żarnowieckie and Raduńskie Dolne.

Lake Żarnowieckie	Lake Raduńskie Dolne	Common parasites
<i>Dactylogyrus fallax</i> <i>Dactylogyrus sphyrna</i> <i>Dactylogyrus wunderi</i> <i>Desmidocerella numidica</i> , L3 Nematoda, n.det.*, L3 <i>Caspiobdella fadejevi</i>	<i>Ichthyocotylurus pileatus</i> , met. <i>Paleorchis incognitus</i> <i>Paracoenogonimus ovatus</i> , met. <i>Rhipidocotyle campanula</i> , met. <i>Sphaerostomum globiporum</i> Digenea, n.det.*, met. <i>Caryophylleus laticeps</i> <i>Philometra ovata</i> <i>Acanthocephalus lucii</i> <i>Caligus lacustris</i> <i>Ergasilus briani</i>	<i>Dactylogyrus crucifer</i> <i>Dactylogyrus nanus</i> <i>Dactylogyrus similis</i> <i>Diplozoon paradoxum</i> <i>Paradiplozoon homoion homoion</i> <i>Bucephalus polymorphus</i> , met. <i>Diplostomum gavium</i> , met. <i>Diplostomum</i> spp., met. <i>Ichthyocotylurus platycephalus</i> , met. <i>Posthodiplostomum cuticola</i> , met. <i>Sphaerostomum bramae</i> <i>Tylodelphys clavata</i> , met. <i>Caryophyllaeides fennica</i> <i>Paradilepis scolecina</i> , pl. <i>Raphidascaris acus</i> , L3 <i>Ergasilus sieboldi</i> <i>Argulus foliaceus</i> <i>Piscicola geometra</i> <i>Anodonta anatina</i> , gl.

gl.: glochidium, L3: the third stage larva, met.: metacercaria, pl.: plerocercus, \*: dead specimens

**Table 21**

List of parasites found in the European perch from Lakes Żarnowieckie and Raduńskie Dolne.

Lake Żarnowieckie	Lake Raduńskie Dolne	Common parasites
<i>Eubothrium crassum</i> , pl. <i>Anisakis simplex</i> , L3 <i>Camallanus truncatus</i> <i>Echinorhynchus gadi</i> <i>Pomphorhynchus laevis</i>	<i>Phyllodistomum folium</i> <i>Rhipidocotyle campanula</i> , met., ad. <i>Proteocephalus</i> spp.* <i>Anguillicoloides crassus</i> , L3 <i>Contraecum</i> sp., L3 <i>Cosmocephalus obvelatus</i> , L3 <i>Desmidocerella numidica</i> , L3 <i>Eustrongylides excisus</i> , L4 <i>Gordionus</i> sp. <i>Pseudanodonta complanata</i> , gl. <i>Unio</i> sp., gl.	<i>Apatemon gracilis</i> , met. <i>Azygia lucii</i> <i>Bunodera luciopercae</i> <i>Diplostomum</i> spp., met. <i>Ichthyocotylurus pileatus</i> , met. <i>Ichthyocotylurus platycephalus</i> , met. <i>Ichthyocotylurus variegatus</i> , met. <i>Tylodelphys clavata</i> , met. <i>Proteocephalus percae</i> <i>Triaenophorus nodulosus</i> , pl. <i>Camallanus lacustris</i> <i>Acanthocephalus lucii</i> <i>Achtheres percarum</i> , ch.IV, ad. <i>Ergasilus sieboldi</i> <i>Argulus foliaceus</i> <i>Piscicola geometra</i> <i>Anodonta anatina</i> , gl.

ad.: adult, ch.IV: the fourth chalimus, gl.: glochidium, L3,4: the third/fourth stage larva, met.: metacercaria, pl.: plerocercoid, \*: juvenile specimens

the Shannon-Wiener diversity index were recorded. According to the Pielou evenness index, the distribution of parasites in this lake was also more uniform. The Berger-Parker index was also lower in the fish from Lake Raduńskie Dolne (Table 22).

Higher values of the Shannon-Wiener diversity index among the communities of metazoan parasites and the Pielou evenness index were obtained for roach, as compared to European perch; and for the former species, values of the Berger-Parker dominance index were the lowest ones (Table 22).

For allogenic parasites, values of the Shannon-Wiener diversity index and the Pielou index of evenness were higher for the roach and the European perch from Lake Raduńskie than for the fish from Lake Żarnowieckie. Communities of allogenic parasites from Lake Raduńskie Dolne had lower values of the Berger-Parker dominance index, with the digenean *T. clavata* as the dominant species for both European perch and roach. In turn, higher diversity and evenness of parasites within the same basin were recorded for roach in both Lake Raduńskie Dolne and Lake Żarnowieckie. Lower dominance indices were also obtained for roach (Figs 92-97).

The diversity of autogenic species' communities was higher for the European perch and roach from Lake Żarnowieckie. The evenness index was also higher in this lake than in Lake Raduńskie Dolne. In turn, higher dominance indices were obtained in the communities associated with roach from Lake Żarnowieckie and with European perch from Lake Raduńskie Dolne. The dominant species were as follows: *B. luciopercae* and *Acanthocephalus lucii* (among specimens of the European perch from Lake Żarnowieckie), *Camallanus lacustris* (among specimens of the European perch from Lake Raduńskie Dolne), *D. crucifer* (among specimens of roach from Lake Żarnowieckie), and *B. polymorphus* (among specimens of roach from Lake Raduńskie Dolne). Within the same water basin, the diversity and evenness were higher in communities of autogenic species among specimens of European perch. Higher dominance in Lake Żarnowieckie, as well as in Lake Raduńskie Dolne was recorded among specimens of roach as compared to European perch (Figs 92-97).

The higher Shannon-Wiener diversity index for communities of ectoparasites was recorded for both roach and European perch from Lake Raduńskie, where the Pielou index of evenness was also higher. In turn, the Berger-Parker dominance index was higher for the fish from Lake Żarnowieckie. The dominant species associated with European perch from both lakes was the copepod *A. percarum*, and with roach – the monogenean *D. crucifer*. Within the same lake, higher diversity and evenness of ectoparasite communities were recorded for roach as compared to European perch from Lake Żarnowieckie, and for European perch as compared to roach in Lake

**Table 22**

Values of the Shannon-Wiener diversity index, Pielou's evenness index and the Berger-Parker dominance index for parasites in roach and European perch from Lakes Żarnowieckie and Raduńskie Dolne.

	Lake Żarnowieckie		Lake Raduńskie Dolne	
	European perch	Roach	European perch	Roach
Shannon-Wiener diversity index	1.028	1.291	1.474	1.795
Pielou index of evenness	0.332	0.401	0.442	0.528
Berger-Parker domination index	0.764 1/D = 1.310	0.482 1/D = 2.075	0.616 1/D = 1.623	0.362 1/D = 2.762

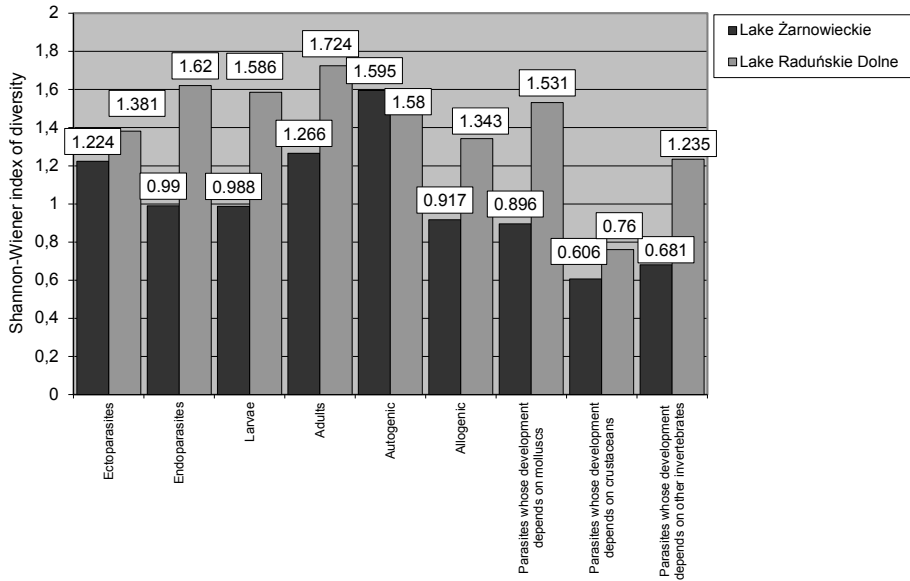
Raduńskie Dolne. Higher dominance was recorded for roach as compared to European perch (Figs 92-97).

The diversity and evenness indices of the endoparasite communities among the fish from Lake Raduńskie Dolne were higher. The dominance was the opposite with higher values determined among the fish from Lake Żarnowieckie. *T. clavata* was the dominant species among both the European perch and roach from both lakes. Within the same lake, higher diversity and evenness for endoparasite communities were recorded among specimens of roach, compared to European perch in both lakes – Żarnowieckie and Raduńskie Dolne, with higher dominance recorded for European perch as compared to roach (Figs 92-97).

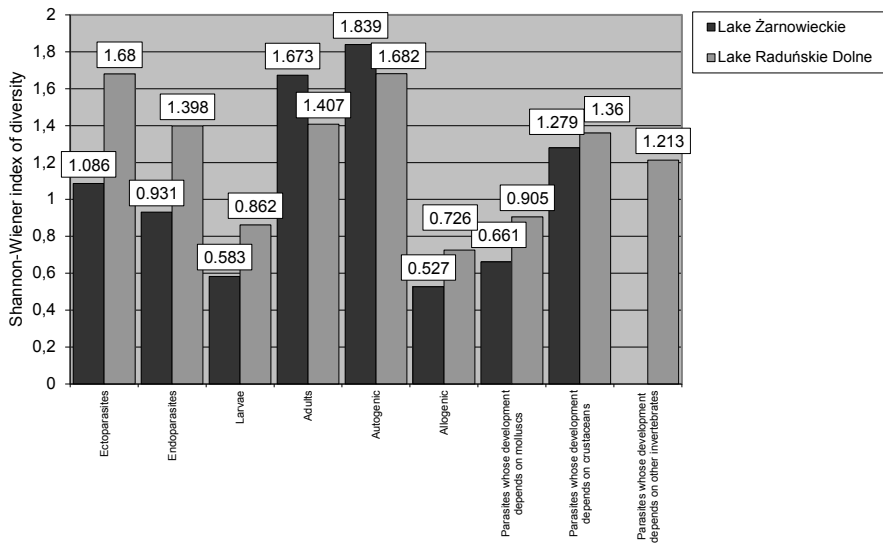
With regard to parasites of larval stages, the Shannon-Wiener diversity index was higher among the fish from Lake Raduńskie Dolne. Also the Pielou index of evenness was higher in that lake. The Berger-Parker dominance index had higher values among the fish from Lake Żarnowieckie. The digenean *T. clavata* was the dominant species among European perch and roach from both lakes. The comparison of fish parasite communities within the same water basin confirmed higher diversity and evenness among roach rather than among European perch in both lakes – Raduńskie Dolne and Żarnowieckie. Higher dominance was characteristic for the larvae collected from European perch (Figs 92-97).

Communities of parasites in the adult stage had higher diversity and evenness indices among the European perch in Lake Żarnowieckie and the roach from Lake Raduńskie Dolne. In turn, the dominance index was higher among the roach specimens in Lake Żarnowieckie and the European perch in Lake Raduńskie Dolne. The dominant species were as follows: *B. luciopercae* and *Acanthocephalus lucii* (for the European perch in Lake Żarnowieckie), *Camallanus lacustris* (for the European perch in Lake Raduńskie Dolne) and *D. crucifer* (for roach in both lakes). The comparison of communities of adult-

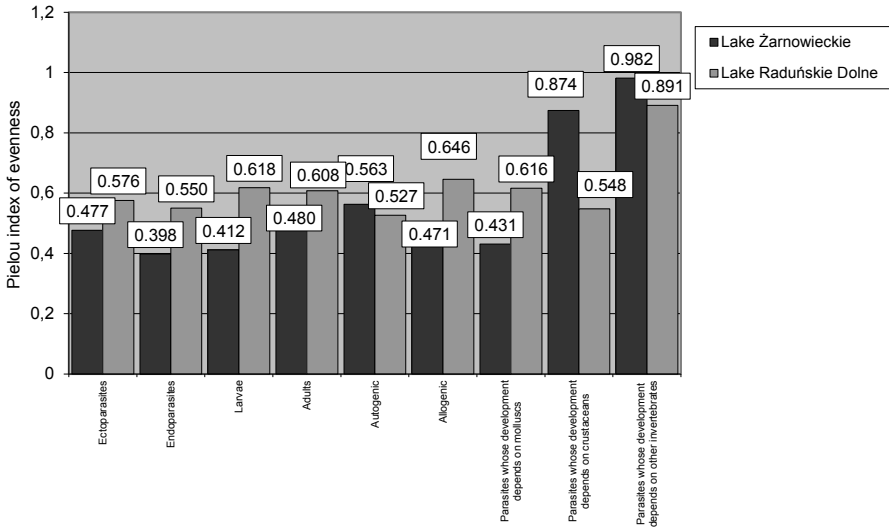




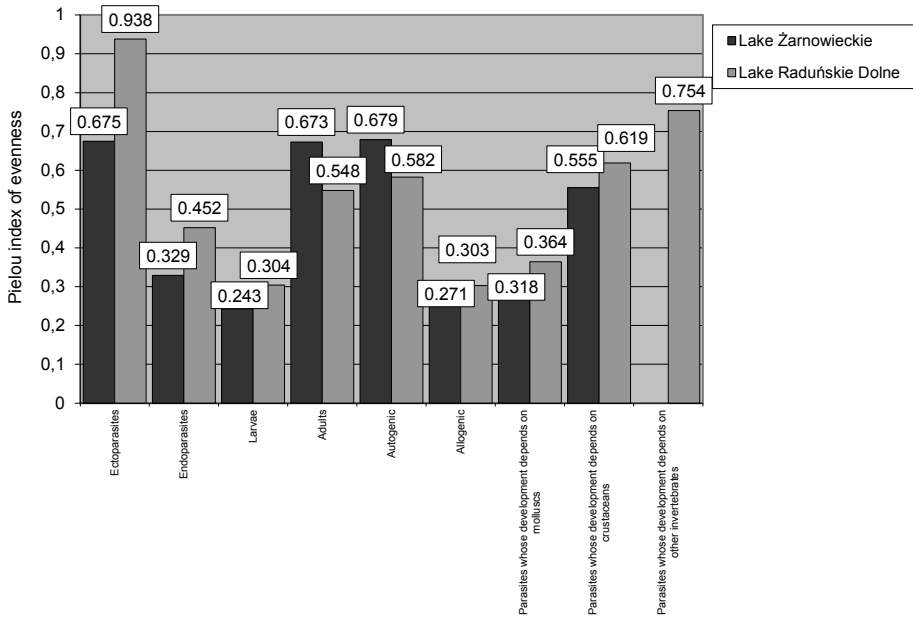
**Fig. 92.** Values of the Shannon-Wiener diversity index for parasite communities in roach from Lakes Żarnowieckie and Raduńskie Dolne.



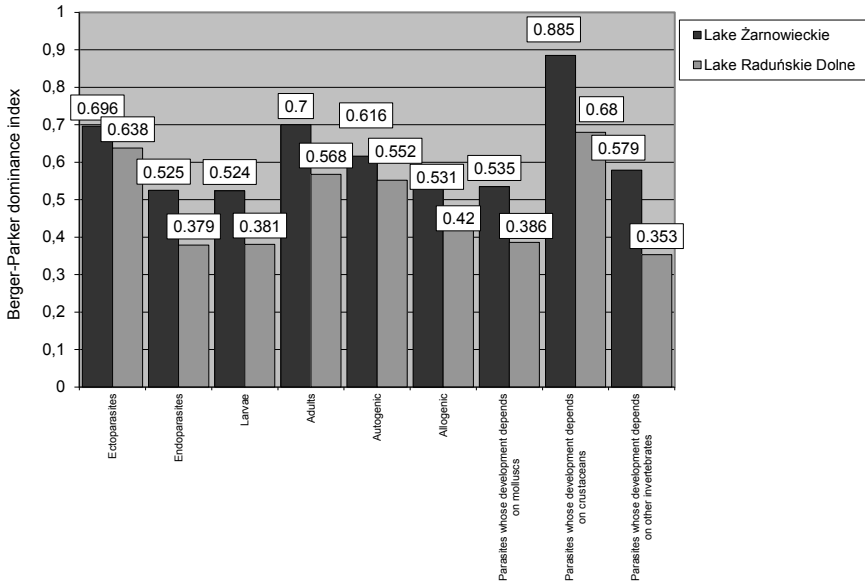
**Fig. 93.** Values of the Shannon-Wiener diversity index for parasite communities in European perch from Lakes Żarnowieckie and Raduńskie Dolne.



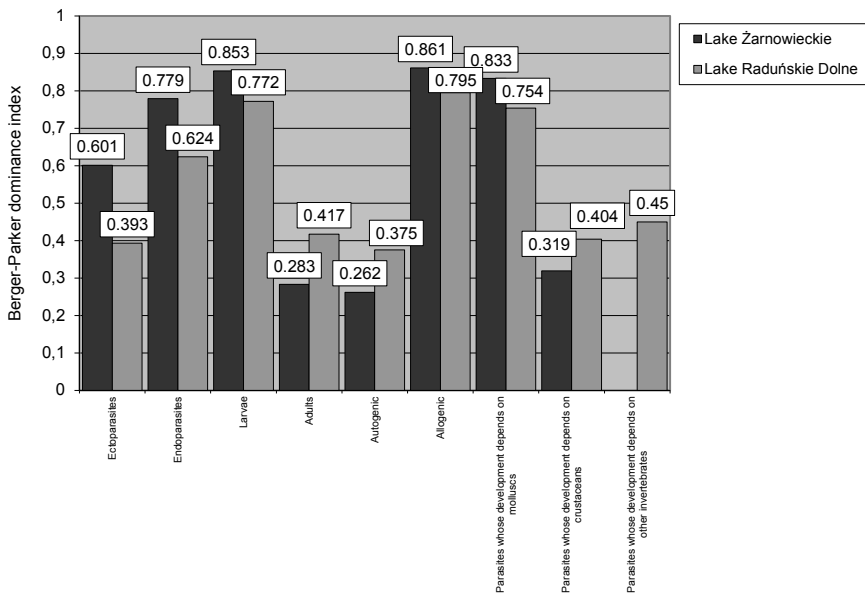
**Fig. 94.** Values of the Pielou evenness index for parasite communities in roach from Lakes Żarnowieckie and Radauńskie Dolne.



**Fig. 95.** Values of the Pielou evenness index for parasite communities in European perch from Lakes Żarnowieckie and Radauńskie Dolne.



**Fig. 96.** Values of the Berger-Parker dominance index for parasite communities in roach from Lakes Żarnowieckie and Raduńskie Dolne.



**Fig. 97.** Values of the Berger-Parker dominance index for parasite communities in European perch from Lakes Żarnowieckie and Raduńskie Dolne.

stage fish parasites within the same water basin confirmed higher diversity and evenness indices among the specimens of European perch as compared to roach in Lake Żarnowieckie, and among roach specimens as compared to European perch in Lake Raduńskie Dolne. Both in Lake Żarnowieckie and in Lake Raduńskie Dolne, the dominance index was higher among specimens of roach than among specimens of European perch (Figs 92-97).

The Shannon-Wiener diversity and Pielou evenness indices were higher in fish from Lake Raduńskie Dolne for communities of parasites that included mollusks in their life cycles. The opposite was determined for the Berger-Parker dominance index; higher values were recorded for communities in Lake Żarnowieckie. In both lakes, *T. clavata* was the dominant species for European perch and roach. Within the same water basin, greater diversity and evenness were recorded for communities in roach than in European perch in Lakes Żarnowieckie and Raduńskie Dolne, while higher dominance was recorded among specimens of European perch as compared to roach (Figs 92-97).

The Shannon-Wiener diversity index was higher in fish from Lake Raduńskie Dolne for communities of parasites that included crustaceans in their life cycles. However, the Pielou index of evenness and the Berger-Parker dominance index were higher for roach in Lake Żarnowieckie and for European perch in Lake Raduńskie Dolne. The dominant species were as follows: *B. luciopercae* and *Acanthocephalus lucii* (among specimens of the European perch in Lake Żarnowieckie), *Camallanus lacustris* (among specimens of the European perch in Lake Raduńskie Dolne) and *P. scolecina* (among roach specimens in both lakes). Within the same water basin, the communities analyzed had higher diversity and evenness values among specimens of the European perch in both lakes as compared to those among the roach specimens. However, higher dominance was recorded for roach as compared to European perch (Figs 92-97).

Communities of parasites with a life cycle stage that occurred in invertebrate groups other than mollusks or crustaceans had greater diversity and were confirmed in the fish from Lake Raduńskie Dolne. Such parasites were not recorded among specimens of the European perch in Lake Żarnowieckie. Higher evenness and dominance were observed in the communities among roach specimens in Lake Żarnowieckie. The dominant species were as follows: the nematode *E. excisus* (among specimens of the European perch in Lake Raduńskie Dolne), the tapeworm *C. fennica* (among roach specimens in Lake Żarnowieckie), and the nematode *R. acus* (among roach specimens in Lake Raduńskie Dolne). Within the same lake, higher diversity and evenness in the analyzed communities were determined for the roach as compared to the European perch in both lakes. The Berger-Parker dominance index was higher for European perch (Figs 92-97).

### ***Similarity of parasite fauna in fish from Lakes Żarnowieckie and Raduńskie Dolne***

The qualitative comparison of the parasite fauna (without dividing it into communities) of a given fish species from both lakes, using the Jaccard faunistic similarity coefficient, revealed a relatively high similarity, which was higher for the roach (0.528) than for the European perch. In turn, the quantitative comparison using the Steinhaus similarity coefficient indicated the opposite – higher similarity (0.876) recorded among specimens of European perch (Table 23).

In turn, similarity between roach and European perch inhabiting the same lake was low and did not exceed 0.500. Qualitatively, greater similarity was recorded among the fish in Lake Raduńskie Dolne (0.208) than among the fish in Lake Żarnowieckie. However, slightly higher quantitative similarity was noted among the fish in Lake Żarnowieckie (Table 23).

The Jaccard faunistic similarity coefficient for four communities identified in the European perch and for six communities in roach were equal to or higher than 0.500. Whereas the Steinhaus similarity coefficient for particular communities was high (mostly >0.500) and even reached the values above 0.900. Only in one case, no similarity was confirmed. Among the six communities, a higher qualitative similarity was confirmed with the Jaccard coefficient for roach than for European perch from both lakes. The similarity was identical in the community of parasites that included mollusks in their life cycles. For ectoparasite communities and parasites in adult stages, a higher qualitative similarity was determined for European perch. While in roach, the Steinhaus coefficient indicated a higher quantitative similarity among ectoparasites, parasites in the adult stage, communities that included crustaceans in their life cycles and in parasite communities with invertebrates other than mollusks or crustaceans in their life cycles. The remaining communities were characterized by a greater quantitative similarity in European perch (Fig. 98, 99).

In turn, similarities among the individual communities in roach and European perch within the same lake were mostly low (Fig. 100, 101). Higher qualitative similarity was determined for most of the communities of parasites in European perch and roach in Lake Raduńskie Dolne than for the same fish species in Lake Żarnowieckie. Only among allogenic communities, a higher similarity was recorded in the fish from Lake Żarnowieckie, while the identical similarity was determined only in the ectoparasite communities. Quantitatively, a higher similarity was determined for four communities in fish from Lake Żarnowieckie. In Lake Raduńskie Dolne, the similarity was higher for ectoparasite communities, allogenic species and parasite communities, whose

**Table 23**

Values of the fauna similarity indices among parasite communities in roach and European perch from Lakes Żarnowieckie and Raduńskie Dolne.

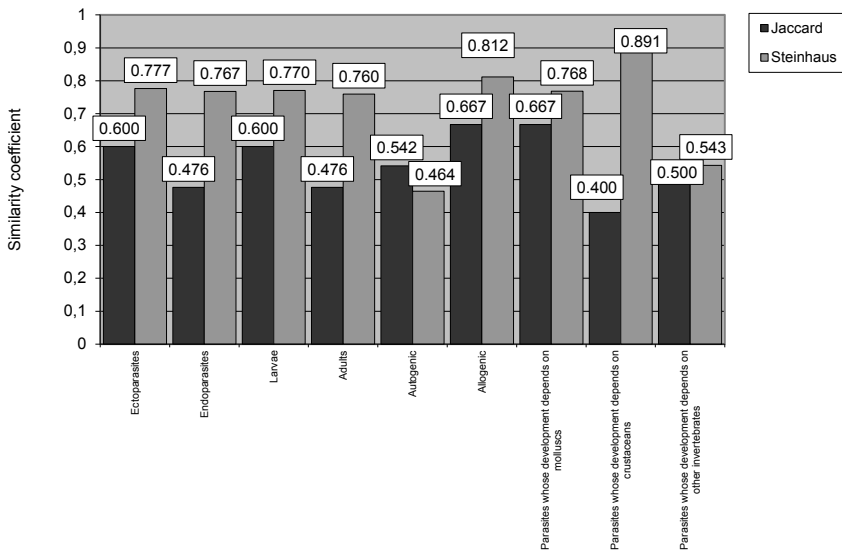
	European perch		Roach	
	Lake Żarnowieckie	Lake Raduńskie Dolne	Lake Żarnowieckie	Lake Raduńskie Dolne
Jaccard faunistic similarity coefficient	0.505		0.528	
Steinhaus similarity coefficient	0.876		0.767	
	Lake Raduńskie Dolne		Lake Żarnowieckie	
	European perch	Roach	European perch	Roach
Jaccard faunistic similarity coefficient	0.208		0.175	
Steinhaus similarity coefficient	0.437		0.461	

development depends on crustaceans, while it was identical for the parasite community that included mollusks in its life cycle. No similarity was confirmed for parasite communities that included crustaceans in their life cycles in Lake Żarnowieckie, or for parasite communities with invertebrates other than mollusks or crustaceans in their life cycles, in both lakes – Żarnowieckie and Raduńskie Dolne.

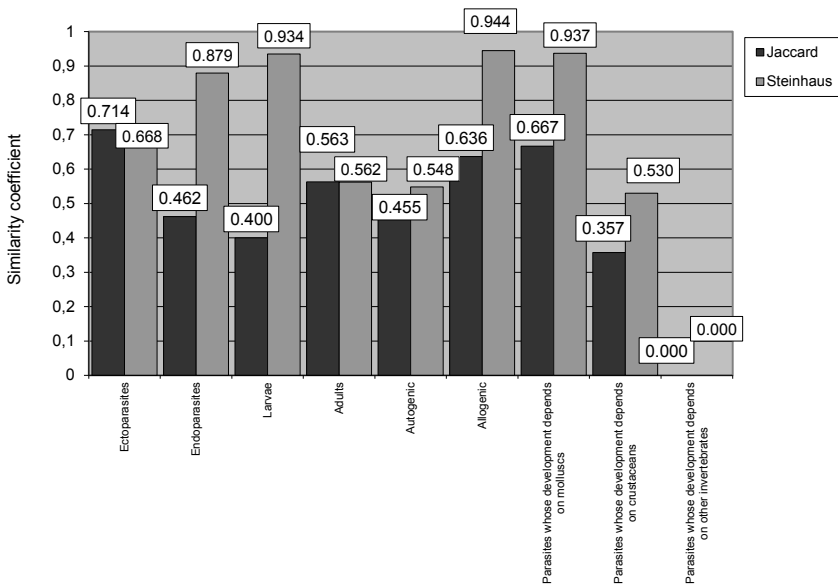
## DISCUSSION

### *General remarks*

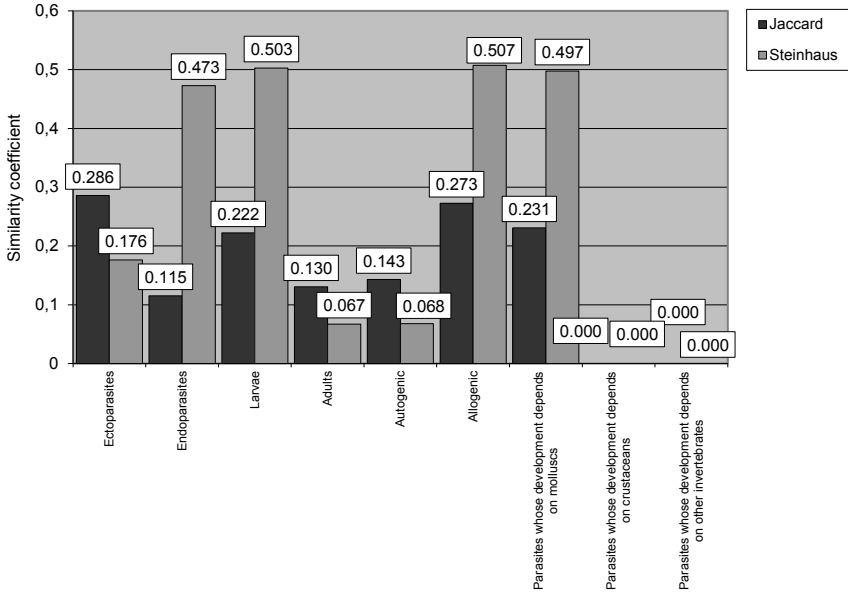
The parasite fauna of fish inhabiting Lakes Raduńskie Dolne and Żarnowieckie has not yet been studied. The only parasitological information available to date is the confirmation of the occurrence of *A. foliaceus* on three-spined stickleback *Gasterosteus aculeatus aculeatus* Linnaeus, 1758, in Lake Raduńskie Dolne (Rolbiecki and Izdebska 2003). The current study indicates that the fish parasite fauna in the two lakes is very rich, with a total of 58 parasite taxa; 48 taxa were recorded in Lake Raduńskie and 40 taxa in Lake Żarnowieckie (Tables 9, 13). The nematode *C. obvelatus* L3 was confirmed as a new parasite among Polish fish. The European perch inhabiting Polish regions was a new host for *A. simplex* L3, *Contraecaecum* sp. L3 and *E. excisus* L4. Additionally, *C. obvelatus* L3 and the nematomorph of the genus *Gordionus* were recorded for the first time in European perch within its entire area of occurrence. Although instances of the occurrence of nematomorphs have been



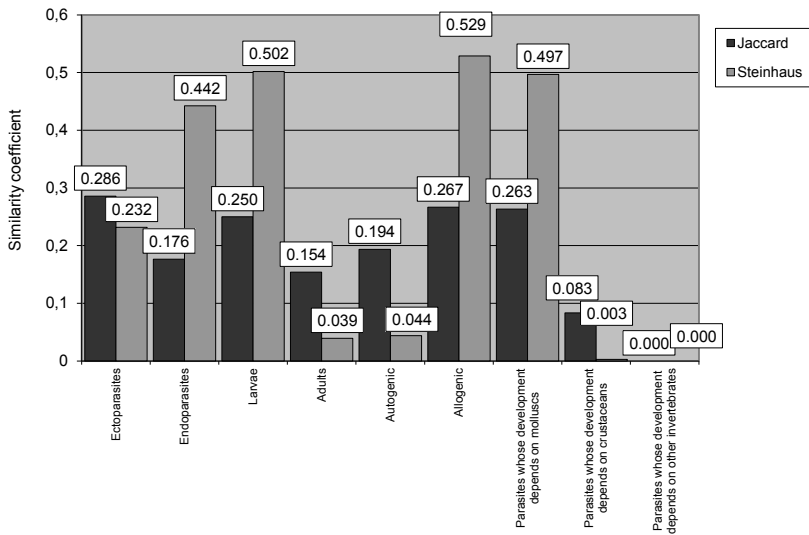
**Fig. 98.** Values of the Jaccard and Steinhaus similarity coefficient indices for parasite communities in roach from Lakes Żarnowieckie and Raduńskie Dolne.



**Fig. 99.** Values of the Jaccard and Steinhaus similarity coefficient indices for parasite communities in European perch from Lakes Żarnowieckie and Raduńskie Dolne.



**Fig. 100.** Values of the Jaccard and Steinhaus similarity coefficient indices for parasite communities in roach and European perch from Lake Żarnowieckie



**Fig. 101.** Values of the Jaccard and Steinhaus similarity coefficient indices for parasite communities in roach and European perch from Lake Raduńskie Dolne.



reported (e.g. Hoffman 1999, Rolbiecki et al. 2003), their infection must be considered as accidental. Arthropods (insects and myriapods) occur throughout the nematomorph life cycle as intermediate hosts, and free-living adult stages can be found in the substrates or mud of water basins. The nematomorphs must have been consumed by the fish, but thanks to their thick body covering they were not digested and most likely were eliminated alive from the fish. Roach from the Polish waters was confirmed to be a new host for metacercariae *Diplostomum*, possibly *D. gavium*. As few as 2044 specimens, which were collected from the vitreous humor of roach were identified as the species *D. gavium* among more than 13,000 collected metacercaria from the genus *Diplostomum*. Adult stages of the digeneans were observed in Poland in red-throated diver *Gavia stellata* (Pontoppidan, 1763) (cf. Okulewicz 1984, Rząd et al. 2008), whereas metacercariae (described as *D. numericum* Niewiadomska, 1988) were recorded in rudd *Scardinius erythrophthalmus* (Linnaeus, 1758) and ruffe *Gymnocephalus cernua* (Linnaeus, 1758) (cf. Niewiadomska 1988, 2003). Nevertheless, the larvae that were found in the present work in roach were slightly smaller than those described by Niewiadomska (1988). Because of the huge morphological similarity in digenean from *Diplostomum* (Niewiadomska 1996), the problem is still unsolved and needs further studies; especially that *D. gavium* was described based on the material (adult digeneans) collected from North America (Guberlet 1922). However, European and American species may represent separate groups as suggested by Niewiadomska (2003).

The current observations indicate that there is a wide range of variation in the studied parasite species. The dimensions of the nematodes *A. simplex* L3, *C. obvelatus* L3, *E. excisus* L4 and metacercariae *D. gavium* found in the analyzed fish often differed from those reported by other authors (Wong and Anderson 1982, Niewiadomska 1988, 2003, Moravec 1994), and this might indicate that there is a wider range in the metric characteristics of these parasites. The dimensions reported by Wong and Anderson (1982) for *C. obvelatus* referred to specimens that had been reared with experimentally infected amphipods. Glochidia that were collected from fish from both lakes – Raduńskie Dolne and Żarnowieckie, and then reared experimentally, also had dimensions different from those reported in the literature. Due to overlapping dimension ranges and sometimes similar builds of hooks of experimentally reared glochidia *U. pictorum* and *U. tumidus*, the larvae collected from the fish were identified to the genus level. Identification was also rendered difficult since shells of some specimens were not dilated, which obstructed a clear view of the long hook structure. Usually the available data refer to descriptions of glochidia collected from clams (Kinzelbach and Nagel 1986, Wächtler et al. 2001). While it is true that the size of glochidia does not vary in most Unionidae, and metamorphosis concerns the internal structures (Wächtler et al.

2001), the lack of detailed descriptions of the larvae collected from the fish might make their identification difficult. It is also difficult to know whether the descriptions of mollusks in the literature (e.g. Bykhovskaya-Pavlovskaya et al. 1964) refer to individuals collected from fish or clams. The descriptions and dimension ranges for the nematode *Contracaecum* L3 and the nematomorph *Gordionus* partially corresponded with the existing descriptions of various species (Moravec 1994, Schmidt-Rhaesa 1997), which is why it was impossible to identify them. Additionally, it is widely accepted that molecular methods are required to positively identify nematodes from the genus *Contracaecum* (Rokicki 2005). It should also be borne in mind that the range of dimensions reported by various authors might result from the analyzed sample size since researchers often report data drawn from a small number of individuals. The applied sample preparation methods might also be important, including different media used during parasite analysis or the type of analyzed material – fresh, frozen, or preserved with formalin.

Infection parameters for fish from both reservoirs were high. The overall level of infection by all metazoan parasites in roach from Lake Raduńskie Dolne was higher (100%, 46.6) as compared to Lake Żarnowieckie (95.1%, 31.7). Whereas the European perch revealed higher prevalence (85.7% and 63.2%, respectively) in Lake Raduńskie Dolne as compared to Lake Żarnowieckie with slightly lower mean intensity (80.3 and 89.7). However, a higher level of infection was recorded among most of the individual parasite species in Lake Raduńskie Dolne.

In Lake Raduńskie Dolne, there were more species of digeneans, tapeworms, nematodes, nematomorphs, copepods and mollusks. The remaining groups of parasites, including monogeneans, acanthocephalans and leeches, were more diversified in Lake Żarnowieckie. Fish lice, however, were represented by the single species of *A. foliaceus* in both lakes. Among the roach and European perch in both lakes, seven common taxa were recorded (*Diplostomum* spp., *I. platycephalus*, *T. clavata*, *E. sieboldi*, *A. foliaceus*, *P. geometra*, *A. anatina*). Seventeen taxa of parasites were identified only in Lake Raduńskie Dolne, including *P. incognitus*, *P. ovatus*, *P. folium* and *R. campanula* (met., ad.), *S. globiporum*, *C. laticeps*, *Proteocephalus* spp., *A. crassus*, *Contracaecum* sp., *C. obvelatus*, *E. excisus*, *P. ovata*, *Gordionus* sp., *Caligus lacustris*, *E. briani*, *P. complanata* and *Unio* spp. Juvenile individuals of *Proteocephalus* probably belong to the species *P. percae*. Nine species were identified only in Lake Żarnowieckie (*D. fallax*, *D. sphyrna*, *D. wunderi*, *E. crassum*, *A. simplex*, *C. truncatus*, *E. gadi*, *P. laevis*, *C. fadejevi*). The roach from Lake Raduńskie Dolne were also confirmed to be infected by digeneans, while those from Lake Żarnowieckie were infected with nematodes, which were not identified because they were dead before the analysis. Parasites confirmed in only one of both

investigated lakes were classified as rare species (*P. ovatus*, *R. campanula* ad., *S. globiporum*, *E. briani*, *Unio* spp.), while the remaining ones were classified as sporadic (*D. fallax*, *D. sphyrna*, *D. wunderi*, *P. incognitus*, *P. folium*, *P. ovata*, Digenea n.det., *C. laticeps*, *E. crassum*, *Proteocephalus* spp., *A. simplex*, *C. truncatus*, *A. crassus*, *Contracaecum* sp., *C. obvelatus*, *E. excisus*, Nematoda n.det., *E. gadi*, *P. laevis*, *Gordionus* sp., *Caligus lacustris*, *C. fadejevi*, *P. complanata*).

Among the fish from Lake Raduńskie Dolne and the roach from Lake Żarnowieckie, digeneans were the dominant group, both qualitatively and quantitatively (Figs 72-75); they were represented by metacercariae *Diplostomum* spp. and *T. clavata* (Tables 3-6). While no dominant species was identified in the European perch from Lake Żarnowieckie, digeneans prevailed. These parasites have a very wide host range, although *T. clavata* prefers roach and European perch, which is why they are one of the most common species in both of these fish species in fresh waters, and even in brackish waters (i.a. Niewiadomska 2003, Rolbiecki 2003, Valtonen et al. 2003, Pojmańska et al. 2007). The infection parameters of these digeneans in roach and European perch were the highest among all the confirmed parasites. The prevalence was as high as 100% (*Diplostomum* spp. in roach from Lake Raduńskie Dolne), and the maximum intensity exceeded 360 parasites in a single fish (*T. clavata* in European perch from Lake Raduńskie Dolne). Comparable results are reported by other authors (i.a. Grabda et al. 1987, Balling and Pfeiffer 1997a, Rolbiecki 2003, Valtonen et al. 2003). The high abundance of *Diplostomum* spp. and *T. clavata* meant that the analysis of communities was dominated by endoparasites over ectoparasites, allogenic over autogenic parasites, and parasites that included mollusks in their life cycles dominated over those that included other invertebrates.

With regard to species qualitative categories, common, rare and sporadic species prevailed over dominant species. However, with regard to quantity, the opposite was observed. Sporadic species (recorded in less than 4% of the examined fish), which were the largest group in qualitative terms, were the smallest group in quantitative terms. In host populations there is usually a characteristic distribution in which the dominant parasites are represented by a few species in great abundance; however, greater species richness was revealed by common species followed by rare species, and the lowest species richness was observed for sporadic species with the corresponding lowest individual abundance.

The parasites were characterized by varied ranges of host specificity. Most of the parasites in both roach and European perch in the two lakes were polyxenic (36 species). Less common were oligoxenic (13), and monoxenic were represented only by the monogenean *D. similis*, which infected roach

(Dzika 2008), and the copepod *A. percarum*, which infected European perch (Kempter et al. 2006). Host specificity was not determined for seven taxa because they were not fully identified. However, the digenean that was identified only to the genus of *Diplostomum* could have been represented by, among others, the common species *D. spathaceum*, which has a wide host specificity range (Niewiadomska 2003). Parasites with wide host specificity have the greatest plasticity and are the least demanding, which is why they are the most common ones. Parasites with single host specificity are at the other extreme, but among specimens of this host species, they are common.

In addition to the above mentioned monoxenic parasites, *D. similis* and *A. percarum*, other parasites were confirmed in the examined fish, and while these were characterized by a greater host specificity, they were also typical in roach and European perch. For roach from both lakes they included *D. crucifer*, *D. nanus*, *P. homoion homoion*, *T. clavata* and *C. fennica*. In turn, the European perch in both lakes hosted *A. gracilis*, *B. luciopercae*, *T. clavata*, *P. percae*, *T. nodulosus*, *Camallanus lacustris* and *Acanthocephalus lucii*, while European perch in Lake Żarnowieckie hosted *E. crassum*. These parasites are often found in roach and European perch from different water basins, as it is confirmed by other faunistic studies (e.g. Grabda 1971, Scholz 1985, Rolbiecki 2003, Mierzejewska et al. 2006, Scholz et al. 2007). Parasites that are typical of fish species other than roach and European perch were also found; they included *D. fallax* (in Lake Żarnowieckie), the main host of which is chub *Squalius cephalus* (Linnaeus, 1758), as well as *D. sphyrna*, *D. wunderi* (in Lake Żarnowieckie), *D. paradoxum* (in both lakes) and *C. laticeps* (in Lake Raduńskie Dolne), which is typical of the freshwater bream (Pojmańska and Cielecka 2001, Dzika 2008). Additionally, *Azygia lucii* (in both lakes) is a typical northern pike parasite (Niewiadomska 2003) and larval stage III of *A. crassus* (in Lake Raduńskie Dolne) is typical of ruffe (Székely 1995, Rolbiecki 2002b).

The obtained data indicate that parasites probably have a negative impact on the fish. The overall value of the condition coefficient (calculated for all Metazoa) for the infected fish (European perch) was lower than for the fish free of parasites. However, all of the roach specimens from Lake Raduńskie Dolne and most roach from Lake Żarnowieckie were infected. It is noteworthy that the value of the condition coefficient depends not only on the occurrence of metazoan parasites, but also on other parasites, not included in the current study, such as Myxozoa, Protozoa, as well as viruses, bacteria and fungi. Additionally, the fish condition varies throughout the annual cycles and is influenced by seasonal changes (particularly seasonal temperature decreases in winter), feeding intensity, or spawning activity. Decreases in the fish condition

are observed especially after spawning (Opuszyński 1983). It is also possible that worse fish condition depends on parasitic infection.

### ***Characteristics of the parasite fauna of fish from Lake Żarnowieckie***

It would have seemed that the changes in Lake Żarnowieckie, which resulted from the construction and operation of the pumped-storage hydropower plant, and particularly fluctuations in the water level that leave a several-meter wide stretch of the exposed shoreline around the lake, could have caused decreases in the fauna richness. However, the parasite fauna of the examined fish, both qualitatively (25 and 22 taxa in roach and European perch, respectively) and quantitatively is comparable, and even sometimes higher, compared to species composition of analogous communities in many lakes of similar character, but which are not subjected to stress resulting from the operation of a hydropower plant. Similar species richness was observed in roach from lakes with moderate degrees of eutrophication in the Mazurian Lake District, where, in different years of the conducted studies, 25 and 24 parasitic Metazoa were recorded in Lake Dgał Wielki, as well as 33 and 33 in Lake Warniak (Grabda et al. 1987, Dzika 2003). However, in basins with high degrees of eutrophication, such as Lakes Ukiel and Wulpińskie, 27 species were recorded (Dzika 2003). In roach from the thermally polluted Konin Lakes – Licheńskie and Gosławskie, 17 and 19 species of parasites were found, while in nearby Lake Gopło, there were 20 taxa (excluding Myxozoa) (Pojmańska et al. 1980). For the sake of comparison, 18 parasitic Metazoa (excluding Myxozoa) were confirmed in the brackish waters of the Vistula Lagoon (Rolbiecki 2003). Meanwhile, the parasite fauna of roach was significantly less rich, and in the coastal Łebsko Lake, which is connected with the Baltic Sea, seven parasitic Metazoa were confirmed in roach (Morozińska 2007) and only six taxa of parasites in the fish from the Vistula River (Dąbrowska 1970).

The parasite fauna of European perch from different basins is also diverse. For example, European perch from Lakes Dgał Wielki and Warniak were confirmed as hosts for 22 and 17 parasitic Metazoa (Grabda et al. 1987), respectively, while in the eutrophic Kortowskie Lake there were 13 taxa of parasites (Dzika et al. 2008). In Lakes Gosławskie, Licheńskie and Gopło, 8, 12 and 15 species of parasites (excluding Myxozoa) were recorded respectively (Pojmańska et al. 1980), while European perch in the coastal Resko Lake were found to have 28 parasitic Metazoa (Wierzbicka et al. 2005), but in Lake Łebsko, they had 17 (excluding Myxozoa) (Morozińska 2008). The parasite species richness of European perch from the rivers differed; for example, in the Vistula River, ten parasitic Metazoa were recorded (Dąbrowska 1970), while in the Mała Panwia River in southern Poland there were only six of them

(Popiołek and Okulewicz 2000). European perch from the brackish waters of the estuary of the Oder River had 11 parasitic Metazoa (excluding Myxozoa) (Sobecka and Słomińska 2007), while those from the Vistula Lagoon had 23 (excluding Myxozoa) (Rolbiecki 2003), the Gulf of Gdańsk – 13 and 11 (Rokicki 1975, Rolbiecki et al. 2002), and the waters of the open Baltic Sea – 24 parasitic Metazoa (Wierzbicka et al. 2005).

It is, however, difficult to compare and interpret the results of studies from different basins. Parasite communities are affected by a wide variety of biotic and abiotic factors linked to the characters of individual water basins (i.e. lentic or lotic waters, fresh waters, fresh/brackish waters, varied trophic status, chemical or thermal pollution). A sample size also affects the results of studies; when more hosts are examined, then the numbers of parasites found usually increases. The period during which a study is conducted is also important, as it takes the seasonality into account. Certain species of parasites, especially rare ones, might appear in a host only during specific times of the year or only during specific phases of the life cycle; they can also have a narrow range of occurrence (Bush et al. 2002, Niewiadomska et al. 2001). In addition to this, the number of parasite species within a given, local ecosystem is always smaller than within the entire area of occurrence of a given host (Poulin 2007).

Thirty years after the hydropower plant went into operation, the comparable, and sometimes even greater species richness of parasites in the fish from Lake Żarnowieckie indicates that the current situation is dynamically balanced. This conclusion appears to be supported by the Shannon-Wiener diversity index, which is mostly higher in comparison to other results (e.g. Kennedy 1997, Byrne et al. 2000, Dzika 2003, Maïllo et al. 2005).

Not much is known how the hydropower plants affect the lake fauna. A few studies focus on the impact of dam construction on the parasite fauna of fish (Bauer and Stolyarov 1970, Waluga and Własow 1988, Loot et al. 2007), and the results indicate that during construction, distinct, sometimes drastic changes occur in the prevailing hydrobiological conditions. Construction projects, such as dams, also contribute to the creation of a new quality biocenosis. This refers mainly to regions in the immediate vicinity of a dam where there is disequilibrium in environmental parameters, thus conditions for the development of limnetic species that prefer stagnant waters. This exerts either an indirect or direct impact on parasites, for example, by lowering the population count, causing the disappearance of certain hosts and/or increase in the count of others. Species with a single-host life cycle, generally protozoans, monogeneans and crustaceans, are affected immediately. Changes in hydrological conditions, especially regulations in the water flow result in the decreased species richness among rheophilic fish species with high oxygen requirements; sometimes they are also replaced by introduced species. Parasitic

crustaceans are more sensitive to changes because of the number of free-living larval stages. In turn, parasites that change hosts have to be divided into two categories. The first one includes planktonic crustaceans that play the role of an intermediate host, which includes tapeworms and sometimes nematodes (i.e. Camallanidae). In the first year of power plant operation, there was a distinct decrease in the level of fish infection followed by a slow growth that most frequently led to the recreation of the original state or the state that was typical for the new environment. The second category of parasites, for which benthic invertebrates are the intermediate host, are digeneans, many nematodes, most acanthocephalans, and, to a lesser degree, tapeworms. Mollusks are hosts of digeneans, higher crustaceans (Amphipoda and Isopoda) for acanthocephalans and some nematodes (Rhabdochonidae), and oligochaetes for tapeworms from the family Caryophyllidea. Decreases, in the fish infection up to and including the complete disappearance of this parasite, were also observed for this group. However, in the case of the tapeworm Caryophyllidae, increases and/or the re-establishment of populations is more distinct than with other groups of parasites since oligochaetes, which are their hosts, are common animals with fewer requirements (Kasprzak 1981, Obolewski and Strzelczak 2008) compared to isopods or amphipods (hosts of acanthocephalans and nematodes). Whereas, the total disappearance of mollusks, which is typical when a hydro power plant is put into operation, leads to a lack of adult digeneans in the fish. Only larvae were recorded in them (*Diplostomum*, *Posthodiplostomum*, *Tetracotyle/Ichthyocotylurus*), which live in fish for up to several years, and this prolong the subsequent period when the parasite diversity declines. The larvae of them inhabit the host tissues before they can be expelled and this contributes to their accumulation.

Sometimes there are increases in the numbers of parasites, especially introduced species, in regions influenced by hydropower plants. This might lead to epizootic, especially among young fish (Bauer and Stolyarov 1970). As reported by Loot et al. (2007), hydropower constructions can increase physiological stress in fish, thus leading to greater susceptibility to parasite infection.

Another issue is the exposition time to stress agents, under the impact of which a new environmental quality is created. For example, in waters that are thermally polluted and have increased temperatures caused by the discharge of post-cooling waters from electric power plants, new parasite taxa can occur even from sub-tropical zones that are introduced by migrating birds. Heated lakes provide advantageous conditions for other thermophilic hosts, including fish that introduce new parasite species. Additionally, waters that are altered thermally have a modifying impact on parasite biology including seasonal

occurrence and maturation periods (Pojmańska et al. 1980, Overstreet 1993, MacKenzie et al. 1995, Moravec et al. 1997).

These examples constitute the evidence for the varied influence exerted by electric power plants on the structure of parasite fauna in fish. Bauer and Stolyarov (1970) reported that the most distinct changes occurred in the first year of hydroelectric power plants operation, but their impact can last for almost twenty years. Following this period, there is a gradual rebuilding of the fauna, including populations of particular parasites. The current study, conducted several decades after the plant was put online, confirms the above thesis. The degree of restoration depends on the requirements of the parasite habitat, as well as on the type of its development and the character of hydrobiological changes. Individual adaptive capabilities also play a significant role. However, only certain groups of hosts and their parasites can be rebuilt. For example, in the Vygozero Reservoir (Karelia, Russia) (Nagibina 1961), populations of snails and certain bivalves (Sphaeridae) were found 12 years after the hydropower plant was put online, while Unionidae – the hosts for the digenean *Bucephalus* – were not found, which is also linked to the lack of glochidia – the parasite molluscan larvae.

The higher species richness recorded for monogeneans and leeches (one more species was confirmed) in Lake Żarnowieckie might have resulted from more favorable water oxygenation resulting from the operation of the pumped-storage hydropower plant. As a rule, the copepods *A. percarum* and *E. sieboldi* were also found more frequently in the fish from Lake Żarnowieckie. It is plausible that another ectoparasites (copepods and especially glochidia) found more favorable living conditions in Lake Raduńskie Dolne. In comparison to strong currents in Lake Żarnowieckie caused by hydropower plant operation, calmer waters of Lake Raduńskie Dolne are more favorable to the development and invasions of free-living ectoparasites, including mollusk larval stages.

In addition to influence exerted the hydropower plant, the character of Lake Żarnowieckie is influenced by the connection with the Baltic Sea through the Piaśnica River, which despite the weir constructed on it, might permit the occurrence of typically marine parasite species. Some of these parasites find in this lake favorable conditions for their development thanks to the occurrence of appropriate hosts, which also migrate either actively or passively to the lake from the sea. Two typical marine parasites (the nematode *A. simplex* and the acanthocephalan *E. gadi*) and one diadromous parasite (the acanthocephalan *P. laevis*) were confirmed in the European perch from Lake Żarnowieckie. *E. gadi* is a typical gadid parasite and is common in the Baltic Sea, and it occurs mainly in the Atlantic cod *Gadus morhua* Linnaeus, 1758 (Rokicki 1995, Sobecka 2007). In turn, *P. laevis* is a species of marine and freshwater fish, which occurs commonly in Poland in coastal waters but less commonly in



inland waters (Grabda 1971, Pojmańska et al. 2007). The main host for *P. laevis* in the southern Baltic Sea is the European flounder *Platichthys flesus* (Linnaeus, 1758) (cf. Kennedy 1984, Chibani and Rokicki 2004). It is plausible that the European perch became infected with acanthocephalan through intermediate hosts (Amphipoda), which migrated to the lake from the Baltic Sea, or possibly European perch that became infected in the sea while migrating to the lake through the Piaśnica River. In turn, the occurrence of the nematode *A. simplex* in fish might be linked to birds, mainly cormorants, that fly from the Baltic Sea in Lake Żarnowieckie. Birds that prey on fish from the Baltic, including herring, which is the main intermediate or paratenic host of *A. simplex* (Anderson 1992, Szostakowska et al. 2005), can become infected (Kanarek and Rolbiecki 2006) and if they vomit the herring into Lake Żarnowieckie, this can be a vector of infection for the European perch. This European perch was a large individual (35.0 cm), thus it would have been able to feed on infected herrings, which are individuals that reach more than 20 cm in length (Myjak et al. 1996, Rolbiecki and Rokicki 2002). It is also possible that the European perch became infected through the consumption of herring remains infected with these nematodes. European perch infection might also have been caused by other fish, such as the three-spined stickleback, which is also a host of *A. simplex* (Køie 2001, Rolbiecki et al. 2001). Since the three-spined stickleback is a small fish, max. 11.0 cm (Froese and Pauly 2011), it is a ready food source. As in the case of the acanthocephalans, the European perch could also have been infected by *A. simplex* in the sea, after which they migrated up the river to the lake. It is noteworthy that a marine clam, the cockle *Cerastoderma glaucum* (Poiret, 1789), was found in the stomachs of two European perch individuals (four specimens of mollusks in each fish) in Lake Żarnowieckie. This is a confirmation of the influence exerted by marine waters on the composition of species inhabiting these waters.

Despite being recognized as typically freshwater species, the tapeworm *E. crassum* and the nematode *C. truncatus* occur in the brackish waters of the southern Baltic (Rolbiecki 2001, 2003, Wierzbicka et al. 2005). This is a possible reason why they were found only in Lake Żarnowieckie, which has a connection with the Baltic Sea.

### ***Characteristics of the parasite fauna of fish from Lake Raduńskie Dolne***

The parasite fauna of the fish from Lake Raduńskie Dolne was rich both qualitatively (28 and 30 taxa in roach and European perch, respectively) and quantitatively, and was usually richer in terms of species composition as compared to analogous communities from many other lakes (see pages 127-

128). Similarly to Lake Żarnowieckie, it was, however, difficult to make direct comparisons between these present results and data from other basins.

There are more and more reports on progressing eutrophication in the Raduńskie Lake network (Szmeja 2006). Among these lakes, Lake Raduńskie Dolne is characterized by a moderate trophic (Bociąg 2006) state that has a slowly increasing trend (RIEP 2002b). The eutrophication of waters is related to intensified primary production caused mainly by higher concentrations of nutritive mineral compounds of nitrates and phosphates, the source of which is a human activity – mainly agriculture, tourism and recreation. This leads to intense vegetation growth, mainly algae, which influences other links in the food chain, including various invertebrates and vertebrates. The intensification of this process leads to far-reaching changes in the communities of aquatic organisms and in the physicochemical parameters of waters, which lead to their degradation. However, at certain stages, progressing eutrophication leads to abundant development of various potential intermediate or definitive hosts, which creates good conditions for the development of a wide range of parasites (Zander and Reimer 2002).

Studies by many authors confirm quantitative and qualitative increases in infection with metazoan parasites in fish when there are increases in eutrophication (Moser and Cowen 1991, Valtonen et al. 1994, MacKenzie 1995, Lafferty 1997, Sures 2004, Poulin 2007). The current results indicate that the present degree of eutrophication in Lake Raduńskie Dolne supports the development of parasites through the richness of hosts. However, the increase of fish infection in eutrophic reservoirs may result from their reduced immunity, which might be conditioned by the abundant microbial growth (Palm and Dobberstein 1999).

The increased eutrophication might be beneficial to parasite growth based on the observations of species richness and parasite diversity in fish inhabiting Lake Raduńskie Dolne. However, further increase of lake eutrophication may be alarming since it may result in a decrease of the parasitofauna diversity (Dzika 2003).

It was a very fascinating experience to find the nematode *C. obvelatus* in specimens of the European perch in the Lake Raduńskie Dolne. This cosmopolitan species in the adult stage is a parasite of various water birds. Although seagulls (Laridae) (Baruš et al. 1978, Andersen 1992) are probably the main hosts for this parasite. *C. obvelatus* larvae L3 were recorded in marine, brackish as well as fresh waters (e.g. Marcogliese 1995, Obiekiezie et al. 1992, Groenewold et al. 1996, Josten et al. 2007, Rückert et al. 2007, Marques et al. 2009), it seems, however, that this parasite prefers brackish waters. In Poland, this nematode (only adult stages) was recorded mainly in brackish water (Kanarek and Rokicki 2005, Pojmańska et al. 2007).

Attention should be paid to alien species of the nematode *A. crassus* from European perch inhabiting Lake Raduńskie Dolne. This parasite has recently been reassigned to the genus *Anguillicoloides* (Moravec 2006). Adult stages of *A. crassus* parasitize swim bladders of eel. This nematode was introduced to Europe from Asia in the early 1980s, and it quickly became a new parasite among the European eel (Neumann 1985, Koie 1991). At present, *A. crassus* occurs in European eels in almost all European countries, as well as in north Africa (Koops and Hartmann 1989, El Hilali et al. 1996, Maamouri et al. 1999). It was also recorded in the American eel *Anguilla rostrata* (Lesueur, 1817) in the United States (Barse and Secor 1999), in the Indonesian shortfin eel *A. bicolor* McClelland, 1844, the giant mottled eel *A. marmorata* Quoy & Gaimard, 1824 and the African longfin eel *A. mossambica* (Peters, 1852) in the Réunion Island (Indian Ocean) (Sasal et al. 2008). The European eel is more susceptible to infection by this parasite and to anguillicolosis compared to the Japanese eel *Anguilla japonica* Temminck & Schlegel, 1846, which had been its host until the introduction in Europe. The life cycle of *A. crassus* includes intermediate hosts, usually copepods (Moravec 1994, De Charleroy et al. 1990), and paratenic hosts, mainly small fish (i.a. Thomas and Ollevier 1992, Székely 1995, Rolbiecki 2002b). Other paratenic hosts of this parasite include amphibians (Moravec and Skorikova 1998) and even snails (Moravec 1996) or aquatic insects (Moravec and Škoriková 1998). Eel, which is the definitive host, becomes infected by preying on invertebrates and small fish that are infected with invasive stage III larvae. Paratenic hosts are especially significant for large eels, which, because of their size, prey on fish more frequently, and L3 larvae have been found in various fish species from many families (i.a. Thomas and Ollevier 1992, Székely 1995, Rolbiecki 2002b, 2004a,b, 2006a).

The occurrence of *A. crassus* in European perch from Lake Raduńskie Dolne indicates that the conditions in the lake are good for its development. Thanks to wide intermediate host specificity, and especially paratenic hosts, *A. crassus* continues to be successful in extending its area of occurrence. It should also be added that the infected eels are used carelessly as stocking material, and recent reports indicate that such material was released into the Vistula Lagoon (Rolbiecki et al. 2008).

### ***Comparison of types and diversity of parasite communities and similarities among the fish from Lakes Raduńskie Dolne and Żarnowieckie***

In the current study, the examined fish from the two lakes in the Pomeranian Lake District were characterized by high indices of diversity that were often higher as compared to those of other basins (e.g. Kennedy 1997, Byrne et al. 2000, Dzika 2003, Maíllo et al. 2005). The overall diversity (which included all

Metazoa parasites) of the parasite fauna of fish, expressed by the Shannon-Wiener index for Lake Raduńskie Dolne, was higher as compared to Lake Żarnowieckie. This was confirmed by the distribution of specimens among different species, and expressed by the decreased dominance of one or a small group of species. Most of the parasite communities identified in the fish from Lake Raduńskie Dolne were characterized by higher degrees of diversity. Only within the range of autogenic parasite communities of both fishes and the adult stages of European perch parasites, these indices were lower. The adult-stage parasites of this community in European perch from Lake Żarnowieckie were also autogenic species. The higher diversity of parasite communities in the fish from Lake Raduńskie Dolne indicates that there is a greater ecological stability there. The prevailing regulation mechanisms permit communities to oscillate near optimal constant values over longer periods, and to return to this value if there are greater random deviations (Niewiadomska et al. 2001).

The allogenic parasite communities, which include many endoparasites, larvae and parasites with complex life cycles, deserve special attention since, contrary to autogenic parasites, they are dependent on external factors. As such, they are better indicators of the impact exerted by these factors on the conditions prevailing in basins. Lake Raduńskie Dolne has highly varied natural surroundings, and it is also one of the systems of lakes. These factors mean that there are greater opportunities for species exchange and for maintaining the dynamic balance. In comparison to Lake Żarnowieckie, there are no significant ecological disturbances in Lake Raduńskie Dolne, which is why it is considered to be an older and more stable biocenosis. Thanks to this, there must be a more complex network of trophic relationships, as well as greater potential host diversity and greater possibilities for contacts among organisms through negative feedback, which reduce fluctuations and, at the same time, increase the stability of the system. Thus, conditions for allogenic species are advantageous in Lake Raduńskie Dolne, and the more stable the system the greater diversity among the parasites inhabiting this basin.

Since the impact of autogenic processes is weaker than the impact of allogenic ones, they lead to stabilization and diversity within a shorter time. Since they prevail in Lake Żarnowieckie, which, following the ecological disruptions caused by the construction and operation of the pumped-storage hydroelectric plant, certainly only recently achieved the stabilization stage. Allogenic communities are more dependent on external factors, and under such new conditions, not only they can fail to stabilize, but they can also become totally destroyed (Odum 1971). The data obtained from the current study indicate that allogenic communities are, in fact, the most complex systems, which is why values of the Shannon-Wiener index of this community were

generally the lowest of all the communities identified for the two species of fish from both lakes (Figs 92, 93).

The range of parasite fauna similarity based on the Jaccard qualitative and Steinhaus quantitative indices indicated a greater similarity (counted for all metazoan parasites) between the same fish species at over 50% and 70%, respectively. Higher qualitative similarity was recorded among roach compared to European perch, while higher quantitative similarity was recorded among European perch compared to roach. In turn, the similarity between roach and European perch from the same lake was very low for both qualitative (less than 21%) and quantitative (less than 50%) ranges (Table 23). Also values of identified parasite communities were always higher among the same fish species (Figs 98-101). Greater parasite fauna similarity among fish belonging to the same species is obvious. Hosts of the same species have the same or similar biology, including feeding preferences and behavior which provide for appropriate, permanent and/or repeatable parasite composition, and facilitates the transmission of parasites. However, the differences that do exist within the lakes indicate there are distinct or specific hydrobiological conditions within the studied environment, which are manifested above all in variable parasite fauna composition and the availability of free-living invertebrate and vertebrate fauna inhabiting them.

### ***Seasonal occurrence of parasites in Lakes Żarnowieckie and Raduńskie Dolne***

Differences in the level of infection were recorded in some of the parasites of fish from both lakes depending on the season of the year in which they were collected. Most of the parasites were found in the summer, with fewer in the fall and spring, rarely or even none found in winter. However, similar trends were rarely observed in the subsequent years. This refers to *D. crucifer* and *R. campanula* in roach and to *B. lucioperace* and *Camallanus lacustris* in European perch from Lake Raduńskie Dolne. The maximum appearances of other species were noted in various seasons of the year. Additionally, variations in the prevalence were often uncorrelated with variations in the intensity.

The factor that has the greatest impact on this phenomenon is the water temperature, which affects ectoparasites directly and endoparasites indirectly through poikilothermic hosts (mostly invertebrates) (Dogiel 1970, Kennedy 1975, Williams and Jones 1994). It affects the feeding activity of fish, and thus regulates the periods and infection of parasites that fish consume with food. Temperature also affects the biology of a parasite itself and other invertebrate hosts, and usually it raises their number and the developmental rate of invasive forms. The maturation of parasites can be related to host biology (i.e.

migrations). Some of the rare parasites appear only at certain times of the year or only during certain phases of the host life cycle. Additionally, they can also occur at higher intensity only at certain times. Other factors, which result in the seasonal occurrence of parasites, include the death of fishes due to their weakened condition which fluctuates and increases particularly in winter following the spawning season. The selection of infected hosts by predators (some fish, birds, mammals), which, in the temperate zone, feed on fish mostly during the spring, summer and fall periods, is also significant.

When investigating the factors affecting the dynamics of parasite occurrence, one should remember that this is a complex phenomenon which is often affected by various, often local factors. Since water basins differ with regard to both abiotic (i.e. oxygenation, surface area, depth, water circulation) and biotic conditions (i.e. host richness, the character of a neighboring biocenosis), the parasites inhabiting them can also exhibit seasonal variation. *P. scolecina* in roach is one example, which in Lake Żarnowieckie showed the highest prevalence in the fall (Fig. 44), while in Lake Raduńskie Dolne mainly in summer (Fig. 43). In turn, *B. luciopercae* in European perch occurred in Lake Raduńskie Dolne in summer (year 2006) and fall (years 2007, 2008) (Fig. 11). For the sake of comparison, *B. luciopercae* occurred mainly in fall and winter in Lake Constance (Germany) (Balling and Pfeiffer 1997b), while in the brackish Vistula Lagoon, the prevalence was the highest in summer and fall (Rolbiecki 2003).

### ***Correlation between parasite occurrence and the length of fish in Lakes Żarnowieckie and Raduńskie Dolne***

Among some of the collected parasites, the correlation was recorded between the occurrence and the length of fish.

The qualitative and quantitative composition of parasites change with the fish age and the growth. However, since the age is not always directly reflected by the length, the dependence between fish length and a degree of parasite infection was analyzed. Fish from different length classes have different life strategies and are exposed to parasites to a different extent. Invasive parasite stages actively infect hosts, or they reach the host passively through food or from the water as the fish breath.

The infection level of various parasites in the fish increased, or sometimes decreased in different length classes. Often, however, these changes fluctuated. In some cases infection increased initially and then decreased. Sometimes infection in all length classes was at a similar level; sometimes parasites occurred only in certain length classes but were absent in other classes. At the

same time, generally there was no correlation between infection parameters (prevalence and mean intensity).

There are many factors influencing the variations in parasite infection among fish of different length classes. They include the size (surface area) of the fish, since it is easier for parasites to locate and infect larger fish. In the current study, these included for example the monogeneans *D. crucifer* in roach from Lake Żarnowieckie and digeneans *P. cuticola* in roach from both lakes, *T. clavata* in roach from Lake Raduńskie Dolne and *A. gracilis* in European perch from Lake Raduńskie Dolne. Additionally, larger fish filter greater amounts of water when breathing, which can allow parasites to settle in or on the fish. This leads to greater infection. One example is the copepod *A. percarum* in European perch; additionally, in the fish from Lake Raduńskie Dolne, copepods occurred only on the fish longer than 18 cm.

It is also important that the host occurs in locations where the invasive larval parasite stages occur. For example, most often the fish come into contact with and are infected by cercariae (*A. gracilis*, *Diplostomum* spp., *Ichthyocotylurus* spp., *P. cuticola*, *R. campanula*, *T. clavata*) in shallow littoral waters inhabited by mollusks, which are the intermediate hosts. In this instance, larger fish appear to be an easier target for parasites. Their shoal life strategies are also significant since greater contact among fish is advantageous for the transmission of parasites. Additionally, shoaling of fish fry or adults during spawning occurs, for example, in shallow regions of water basins that are inhabited by invertebrates, which are the intermediate hosts of parasites. On the other hand, larger fish are more mobile and, in comparison to smaller fish, spend less time near the shores.

The accumulation of parasites through one or more vegetative seasons, which happens with some long-lived larval stages, might also be important (Chubb 1979). In the current study, this might refer to *P. cuticola*, since infection of this parasite increased as the fish length increased. As reported by Dönges (1964), metacercariae can live in fish for as long as 3.5 years.

In many instances, parasites infect hosts with the food the fish consume, which includes various invertebrates and vertebrates that are intermediate or paratenic hosts. In the material collected for the current study, these included *B. lucioperca*, *T. nodulosus* and *P. scolecina* from copepods as the intermediate hosts (Pojmańska and Cielecka 2001, Niewiadomska 2003), *Camallanus lacustris* from copepods, water slaters *Asellus aquaticus* (Linnaeus, 1758) and odonates (*Agrion*) (cf. Grabda-Kazubska and Okulewicz 2005), and *Acanthocephalus lucii* from water slaters (Kennedy 2006). Additionally, the type of food consumed by fish changes throughout their lives, and the food of fish from different populations can also differ, which is related to the specifics of a given basin, including the species composition, and the availability of the

inhabiting fauna. The seasonal occurrence of the intermediate host itself and the seasonal fish host behaviors, such as spawning or migrating that occur in particular seasons of the year are also significant. In this case, the type of food consumed by the fish influences the composition of the parasites inhabiting them, and this pertains to individual length classes. This is why parasite fauna compositions can be used as indicators of the habitat inhabited by the fish, the food they consume, or even migrations they undertake.

The decreasing infection levels until the total lack of parasites in the fish in subsequent length classes are also affected by predatory fish, birds and mammals. Roach infected with metacercariae of *D. gaviium* and plerocercus of *P. scolecina* are an example. The definitive hosts of these parasites are aquatic birds, specifically loons *Gavia* (Niewiadomska 2003) and cormorants *Phalacrocorax* (Pojmańska and Cielecka 2001), respectively. At present, roach infected with the digenean *D. gaviium* are often noted to have acutely inflamed eyes. The digenean of the genus *Diplostomum* often impair the vision of fish and can even cause cataracts. The infected fish stay near the water surface for longer periods and thus are exposed to greater elimination by piscivorous birds, which are the definitive host of these parasites (Kennedy 1975, Crowden and Broom 1980, Paperna 1995, Roberts 2001).

Processes for limiting the abundance of parasites in hosts are also observed. These include elimination of the parasite from the host through interactions between the parasite and the host immune response. On the other hand, decreases in the fish resistance caused by various factors, which are usually difficult to identify under natural conditions, but can include the parasites themselves, can lead to subsequent infections. Intraspecific and interspecific interactions are also observed within and among parasite species in the same habitat.

In conclusion, the issue of correlation between the parasite occurrence and the fish length is highly complex. Often the occurrence of a given parasite species is a result of many factors among which it is difficult to identify the most significant one (Rolbiecki 2006b). The results confirm that fish from different length classes can exhibit various levels of infection under different conditions, or in different basins. This is the evidence of the biological specifics of individual ecosystems that are shaped by variable local factors.

### ***Habitat preferences of the copepod *Achtheres percarum* in the European perch***

Topographical or topic specialization refers to the process of parasites occupying various habitats on or within the host body. Parasites occupy certain habitats on or inside hosts, which ensure them good living conditions. This



phenomenon refers to both endoparasites and ectoparasites. The location of copepods on hosts has been discussed by many authors (i.a. Kabata and Couses 1977, Kabata 1987, Piasecki 1993, 1995, Pike and Wadsworth 1999, Rolbiecki and Rokicki 2000, Rolbiecki 2004c), but although *A. percarum* is a common European perch parasite, its habitat preferences have only been addressed peripherally in studies of other topics (Kozikowska et al. 1956).

*A. percarum* is a specific European perch parasite. Another species of this genus, *A. sandrae*, which infects pike-perch *Sander lucioperca* (Linnaeus, 1758), has long been considered a synonym of *A. percarum* (Kempter et al. 2006, Piasecki and Kuźmińska 2007). *A. percarum*, which was previously described as a parasite of pike-perch, must be recognized as *A. sandrae*.

The copepods collected during the present study exhibited typical distribution. Most of the parasites were located on the gills and only a few individuals were found in mouth cavities. A decrease in the copepod abundance was observed from the external gill arch toward the interior (counting from the operculum), and the parasites preferred the gill rakers from the first bony gill arch (Fig. 66). Kozikowska et al. (1956) also reported that most of the copepods in European perch occurred in the mouth cavity and on the gill rakers, with only a few specimens on the gill filaments.

Many researchers (e.g. Llewellyn 1956, Davey 1980, Rhode 1982, Dorovskih 1988) contend that the most important factor influencing the distribution of parasites on the gills is the direction of water flow through the mouth cavity and the gills. This is especially true because copepods also use water flow to reach fish. After reaching the fish gill cavity, parasites migrate towards the neighboring gill or to a location in the cavity where water flow is the weakest in order to avoid being washed out of the fish. When fish breathe actively, water moves through the fish mouth opening and it flows through the gill cavity and then flows vertically toward the bottom through the gill slits. The precise respiratory mechanism, including the direction in which the water flows through the gills, differs in different fish species, which is probably why there are differences in descriptions of the parasite location. A key question might also be the surface of the occupied gill, which is also linked to the availability and the type of food consumed.

In the case of *A. percarum*, however, a more significant question with regard to parasite distribution is the build of the gills, especially the filtration apparatus. In the European perch it comprises long, thickly placed gill rakers on the first gill with short gill rakers dispersed sparsely on the other gills (Fig. 66). This build and gill raker distribution mean that larval stages of parasites infesting the fish are halted on the long gill rakers of the first gill, which act as a type of net that denies parasites the access to the fish. It appears that this also prevents copepod migration to other parts of the gills. This might be confirmed

by the location of *A. sandrae* in pike-perch (Rolbiecki and Rokicki 2000). The gills of this species have small numbers of dispersed rakers that do not limit copepods from settling in various locations of the gills, even the gill filaments. *A. sandrae* were located mainly on the first gill of pike-perch. However, differences in the number of copepods between the first and the fourth gill arches ranged from 35.5 to 17.2% (Rolbiecki and Rokicki 2000), while for *A. percarum* in the current study, it was 81.2-4.5%. Additionally, the distribution of *A. sandrae* within the bony gill arch (including the gill rakers) and the gill filaments was similar.

## CONCLUSIONS

- The parasite fauna of the European perch and roach from Lakes Żarnowieckie and Raduńskie Dolne were characterized by high species richness and diversity. The European perch and roach infection in Lake Żarnowieckie was 63.2%, 89.7, 1-201 and 95.1%, 31.7, 1-115, respectively, while in Lake Raduńskie Dolne it was 85.7%, 80.3, 1-394 and 100.0%, 46.6, 1-374, respectively. The nematode *Cosmocephalus obvelatus* L3 was confirmed, which is a new species to Polish fish. Roach was identified as a new host in Poland for the parasite *Diplostomum gavium* met., while European perch was a new host for *Anisakis simplex* L3, *Contracaecum* sp. L3, and *Eustrongylides excisus* L4. Additionally, *C. obvelatus* L3 and the nematomorph of the genus *Gordionus* was found for the first time on the European perch within its entire area of occurrence.
- Monogenea were the qualitative dominants in the roach from Lake Żarnowieckie, and Digenea in other fish. In turn, Digenea were always the quantitative dominant in all fish. Metacercariae *Diplostomum* spp. and *Tylodelphys clavata* prevailed in of all the examined fish. Large quantities of these digeneans influenced the abundance structure of selected communities. Thus, endoparasites dominated over ectoparasites, allogenic parasites over autogenic, larvae over adult stages, and parasites with mollusks in their life cycles over those that included other invertebrates.
- The high species richness and diversity among the parasites in the fish of Lake Raduńskie Dolne can indicate that the degree of eutrophication is advantageous to parasite development.
- Despite the changes that have occurred in Lake Żarnowieckie as a result of the construction and operation of the pumped-storage hydropower plant, it appears that the current prevailing state is one of dynamic balance.

- The connection between Lake Żarnowieckie and the Baltic Sea means that typical marine species also inhabit the lake.
- The recorded parasite fauna similarity was greater between the same species of fish from different lakes than between different species from the same lake, which is related to similar biology of the hosts and the development of parasite host preferences.
- Differences in the infection of fish in different seasons of the year refer to some parasites. Most of the parasites were recorded in summer, with fewer in fall and spring, and the least in winter. The maximum occurrence of other species was observed in different seasons of the year.
- The occurrence of some of the parasite species was correlated with the fish length. Parasite infection increased among some species, while for others it decreased in different length categories. Often, however, these changes fluctuated.
- Since it is likely that a nuclear power plant will be built near Lake Żarnowieckie, the results of the current study will provide a baseline for further studies on the impact exerted by the pumped-storage hydropower plant and industrial exploitation on this lake.

#### ACKNOWLEDGMENT

The printing of this publication was financed by the Dean of the Faculty of Biology, the University of Gdańsk.

#### REFERENCES

- Afanasjew S.A., Protasow A.A., Zdanowski B., 1996, *Composition and structure of the zoobenthos in lake littoral, channel and upper reservoir of a pumped-storage power plat* [in:] *The state of Lake Żarnowieckie after ten years exploitation by the pumped-storage Żarnowiec Hydropower Plant, Monografie Komitetu Gospodarki Wodnej PAN, No. 11*, Ed. Majewski W., Politechnika Warszawska, Warszawa: 125-131, (in Polish with Engl. summ.)
- Anderson R.C., 1992, *Nematode parasites of vertebrates, their development and transmission*, Wallingford, CAB International, pp. 578
- Balling T.E., Pfeiffer W., 1997a, *The parasitism of fish from Lake Constance – a comparison of present and earlier data*, Parasitol. Res., 83: 793-796
- Balling T.E., Pfeiffer W., 1997b, *Seasonal differences in infestation of the perch *Perca fluviatilis* L. from Lake Constance with digenean trematodes*, Parasitol. Res., 83: 789-792
- Barse A.M., Secor D.H., 1999, *An exotic nematode parasite of the American Eel*, Fisheries 24: 6-10
- Baruš V., Sergeeva T.P., Sonin M.D., Ryzhikov K.M., 1987, *Helminths of fish-eating birds of the Palaearctic Region. 1. Nematoda*, USSR Academy of Sciences, Czechoslovak Academy of Sciences, Moscow, Prague, pp. 318
- Bauer O.N., ed., 1987, *Key to the parasites of freshwater fish of the USSR. Metazoan parasites. Vol. 3, fasc. 2*, Leningrad, Izdatel'stvo Nauka, pp. 583, (in Russian)

- Bauer O.N., Stolyarov V.P., 1970, *Formation of the parasite fauna and parasitic diseases of fishes in hydro-electric reservoirs* [in:] *Parasitology of fishes*, Eds. Dogiel V.A., Petrushevski G.K., Polyanski Yu.I., Translated by Z. Kabata, Hong Kong, TFH, pp: 246-254.
- Berland B., 2005, *Whole mounts*, Occasional publication No. 1. Malaysia, Institute of Oceanography Kustem, pp. 54
- Bielecki A., 1997, *Fish leeches of Poland in relation to the Palaearctic piscicolines (Hirudinea: Piscicolidae: Piscicolinae)*, Genus 8: 223-375
- Bociąg K., 2006, *Submerged vegetation of Lake Raduńskie Dolne* [in:] *The Raduńskie Lakes. Anthropogenic transformations and directions for protection*, Eds. Wołos A., Nedoszytko B., Olsztyn, IRS: 57-60 (in Polish)
- Boruchalska I., Bukowski J., Gazda K., Gorzeń A., Kochanowska J., et al., 2003, *Environmental report status of the Pomoranian Province based on monitoring studies conducted in 2002*, Biblioteka Monitoringu Środowiska, Gdańsk, Wojewódzki Inspektorat Ochrony Środowiska, pp.172, (in Polish)
- Bush A.O., Fernández J.C., Esch G.W., Seed J.R., 2002, *Parasitism. The diversity and ecology of animal parasites*, Cambridge, University Press, pp. 566
- Bykhovskaya-Pavlovskaya I.E., Gusev A.V., Dubinina M.N., Izyumova N.A., Smirnova T.S., Sokolovskaya I.L., Shtein G.A., Shul'man S.S., Epshtein V.M., 1964, *Key to parasites of freshwater fish of the U.S.S.R.*, Jerusalem, Translated from Russian, Israel Program for Scientific Translations, pp. 919
- Byrne C.J., Grey C., Holland C., Poole R., 2000, *Parasite community similarity between four Irish lakes*, J. Helminthol., 74: 301-305
- Chibani M., Rokicki J., 2004, *Seasonal occurrence of parasites of flounder *Platichthys flesus* (L.) from the Gulf of Gdańsk*, Ocean. Hydrob. Stud., 33: 17-30
- Choiński A., 2006, *Catalog of Polish lakes*, Poznań, Wyd. Naukowe UAM, pp. 600, (in Polish)
- Chubb J. C., 1979, *Seasonal occurrence of helminths in freshwater fishes. Part II. Monogenea*, Adv. Parasit., 17: 141-313
- Crowden A.E., Broom D. M., 1980, *Effects of the eyefluke, *Diplostomum spathaceum*, on the behaviour of dace (*Leuciscus leuciscus*)*, Anim. Behav., 28: 287-294
- Czerwiński T., Wołos A., 2006, *Commercial and recreational fisheries management in the Raduńskie lakes*, [in:] *The Raduńskie Lakes. Anthropogenic transformations and directions for protection*, Eds. Wołos A., Nedoszytko B., Olsztyn, IRS: 57-60 (in Polish)
- Davey J.T., 1980, *Spatial distribution of the copepod parasite *Lernanthropus kroyeri* on the gills of bass, *Dicentrarchus labrax* (L.)*, J. Mar. Biol. Assoc. UK, 60: 1061-1067
- Dąbrowska Z., 1970, *Fish parasites of the Vistula River near Warszawa*, Acta Parasitol. Pol., 17: 189-193
- De Charleroy D., Grisez D., Thomas K., Belpaire C., Ollevier F., 1990, *The life cycle of *Anguillicola crassus**, Dis. Aquat. Org., 8: 77-84
- Dogiel V.A., 1970, *Ecology of the parasites of freshwater fishes* [in:] *Parasitology of fishes*, Eds. Dogiel V.A., Petrushevski G.K., Polyanski Yu.I., Hong Kong, Translated by Z. Kabata, T.F.H. Publications: 1-47
- Dorovskih G.N., 1988, *Distribution of parasites on the gills of rudd*, Parazitologîâ 22: 76-83, (in Russian with Engl. summ.)
- Dönges J., 1964, *Der Lebenszyklus von *Posthodiplostomum cuticola* (v. Nordmann 1832) Dubois 1936 (Trematoda, Diplostomatidae)*, Z. Parasitenkd., 24: 169-248
- Dzika E., 1987, *A modified method of collecting minute Monogenea from fish gills*, Wiad. Parazytol., 33: 99-101, (in Polish with Engl. summ.)
- Dzika E., 2003, *Metazoan parasites of roach *Rutilus rutilus* (L.) in the lakes of Mazury District as a quality indicator of aquatic environment*, Uniwersytet Warmińsko-Mazurski, Olsztyn. Dissertations and Monographs 73: 1-81, (in Polish with Engl. summ.)

- Dzika E., 2008, *Parasites of Polish fish (identification key). Monogenean trematodes – Monogenea*, Warszawa, Polskie Towarzystwo Parazytologiczne, pp. 189, (in Polish)
- Dzika E., Kuształa A., Kuształa M., 2007, *Parasites of carp bream, *Abramis brama*, from Lake Jamno, Poland*, *Helminthologia* 44: 222-225
- Dzika E., Kuształa M., Kozłowski J., 2008, *Metazoan parasite fauna of fish species from lake Kortowskie*, *Arch. Pol. Fish.*, 16: 75-86
- El Hilali M., Yahyaoui A., Sadak A., Maachi M., Taghy Z., 1996, *Première données épidémiologiques sur l'anguillulose au Maroc*, *Bull. Fr. Pêche Piscic.*, 340: 57-60
- Froese R., Pauly D., (eds.) 2011, *FishBase. World Wide Web electronic publication*, www.fishbase.org, version (02/2011)
- Gołębiewski R., 1976, *Bottom sediments of the Raduńskie Lakes*, Gdańsk, Gdańskie Towarzystwo Naukowe, Wydział Nauk o Ziemi, pp. 90, (in Polish)
- Grabda J., 1971, *Catalogue of polish parasite fauna, part 2, Parasites of fishes and cyclostomates*, Wrocław, PWN, pp. 304, (in Polish)
- Grabda-Kazubska B., Baturó-Warszawsa B., Pojmańska T., 1987, *Dynamics of parasite infestation of fish in lakes Dgal Wielki and Warniak in connection with introduction of phytophagous species*, *Acta Parasitol. Pol.*, 32: 1-28
- Grabda-Kazubska B., Okulewicz A., 2005, *Parasites of Polish fish (identification key). Nematods – Nematoda*, Warszawa, Polskie Towarzystwo Parazytologiczne, pp. 168, (in Polish)
- Groenewold S., Berghahn R., Zander C.D., 1996, *Parasite communities of four fish species in the Wadden Sea and the role of fish discarded by the shrimp fisheries in parasite transmission*, *Helgoländer Meeresunters.*, 50: 69-85
- Guberlet J.E., 1922, *Three new species of Holostomidae*, *J. Parasitol.*, 9: 6-14
- Guillen-Hernandez S., Whitfield P.J., 2004, *Intestinal helminth parasites in flounder *Platichthys flesus* from the River Thames: an infracommunity analysis*, *J. Helminthol.*, 78: 297-303
- Halmetoja A., Valtonen E.T., Koskeniemi E., 2000, *Perch (*Perca fluviatilis* L.) parasites reflect ecosystem conditions: a comparison of a natural lake and two acidic reservoirs in Finland*, *Int. J. Parasitol.*, 30: 1437-1444
- Hoffman G.L., 1999, *Parasites of north American freshwater fishes*, Cornell University Press Ithaca, London, Comstock Publishing Associates, pp. 539
- Humes A.G., Gooding R.U., 1964, *A method for studying the external anatomy of copepods*, *Crustaceana* 6: 238-240
- Jańczak J., ed., 1997, *Atlas of Polish Lakes*, Poznań, Bogucki Wydawnictwo Naukowe, pp. 256, (in Polish)
- Jarzębińska T., 1996, *Characteristics of the lake and its catchment [in:] The state of Lake Żarnowieckie after ten years exploitation by the pumped-storage Żarnowiec Hydropower Plant, Monografie Komitetu Gospodarki Wodnej PAN, No. 11*, Ed. Majewski W., Politechnika Warszawska, Warszawa: 7-21, (in Polish with Engl. summ.)
- Jeziński G., 2005, *Nuclear energy yesterday and today*, Warszawa, Wyd. Techniczne, pp. 525 (in Polish)
- Jezewski W., 2006, *Analysis of long-term thermal pollution on helminth fauna of bream (*Abamis brama*) from the Gosławskie Lake*, PhD Thesis, Witold Stefański Institute of Parasitology, Warszawa, pp. 79, (in Polish)
- Josten N., Detloff K.C., Zander C.D., 2009, *Analysis of a parasite supra community from the Flensburg fjord*, *Parasitol. Res.*, 104: 449-461
- Kabata Z., 1987, *The developmental stages of *Neobrachiella robusta* (Wilson, 1912), a specific copepods of *Sebastes* (Teleostei: Scorpeniformes)*, *Can. J. Zool.* 65: 1331-1336
- Kabata Z., Cousens B., 1977, *Host-parasite relationships between sockeye salmon, *Oncorhynchus nerka*, and *Salmincola californiensis* (Copepoda: Lernaepodidae)*, *J. Fish. Res. Board Can.* 34: 191-202

- Kasprzak K., 1981, *Key to invertebrates of Poland, vol.4. Aquatic oligochaetes, I*, Warszawa, PWN, pp. 226, (in Polish)
- Kanarek G., Rokicki J., 2005, *The status of studies on the helminth fauna of the Great Cormorant (Phalacrocorax carbo sinensis) in northern Poland*, Wiad. Parazytol., 51: 165
- Kanarek G., Rolbiecki L., 2006, *Third-stage larvae of Anisakis simplex (Rudolphi, 1809) in the Great Cormorant [Phalacrocorax carbo sinensis (Blumenbach, 1798)] from the Vistula Lagoon, Poland*, Ocean. Hydrob. Stud., 35: 23-28
- Kearn G., 2004, *Leeches, lice and lampreys. A natural history of skin and gill parasites of fishes*, Dordrecht, Springer, pp 432
- Kempton J., Piasecki W., Więski K., Krawczyk B., 2006, *Systematic position of copepods of the genus Achtheres (Crustacea: Copepoda: Siphonostomatoida) parasitizing perch, Perca fluviatilis L., and zander, Sander lucioperca (L.)*, J. Fish Dis., 29: 103-113
- Kennedy C.R., 1975, *Ecological animal parasitology*, Oxford, Blackwell Scientific Publication, pp. 163
- Kennedy C.R., 1984, *The status of flounders, Platicthys flesus L., as hosts of the acanthocephalan Pomphorhynchus laevis (Müller) and its survival in marine conditions*, J. Fish Biol. 24: 135-149
- Kennedy C.R., 1997, *Long-term and seasonal changes in composition and richness of intestinal helminth communities in eels Anguilla anguilla of an isolated English river*, Folia Parasit., 44: 267-273
- Kennedy C.R., 2006, *Ecology of the Acanthocephala*, Cambridge, University Press, pp. 249
- Kennedy C.R., Berrilli F., Di Cave D., De Liberato C., Orecchia P., 1998, *Composition and diversity of helminth communities in eels Anguilla anguilla in the River Tiber: long-term changes and comparison with insular Europe*, J. Helminthol., 72: 301-306
- Khan R.A., Thulin J., 1999, *Influence of pollution on parasites of aquatic animals*, Adv. Parasitol., 30: 201-238
- Kinzelbach R.K., Nagel K.O., 1986, *Redescription of the glochidium of Pseudanodonta complanata (Bivalvia, Unionidae)*, Verh. Naturwiss. Ver. Hamburg 28: 65-74
- Køie M., 1991, *Swimbladder nematodes (Anguillicola spp.) and gill monogeneans (Pseudodactylogyrus spp.) parasitic on the European eel Anguilla anguilla*, J. Cons. Int. Explor. Mer., 47: 391-398
- Køie M., 2001, *Experimental infections of copepods and sticklebacks Gasterosteus aculeatus with small ensheathed and large third-stage larvae of Anisakis simplex (Nematoda, Ascaridoidea, Anisakidae)*, Parasitol. Res., 87: 32-36
- Kondracki J., 1994, *Geography of Poland. Physical-geographical Mesoregions*, Warszawa, PWN, pp. 364 (in Polish)
- Koops H., Hartmann F., 1989, *Anguillicola-infestations in Germany and in German eel imports*, J. Appl. Ichthyol., 1: 41-45
- Kozikowska Z., Jara Z., Grabda E., 1956, *Achtheres percarum Nordm. in European perch and pike-perch. An attempt to explain mutual relationships of the percarum and sandrae forms*, Zool. Polon. 7: 219-267
- Krebs C.J., 1994, *Ecology. The experimental analysis of distribution and abundance*, New York, Harper Collins College Publishers, pp. 801
- Krzykowski S., Więcaszek B., Keszka S., Antoszek A., 2001, *Systematics of cyclostomes and fish. Guide for exercises*, Szczecin, Akademia Rolnicza, pp. 437 (in Polish)
- Kudelska, D., Cydzik, D., Soszka, H., 1994, *Guidelines for basic lake monitoring*, Warszawa, Państwowa Inspekcja Ochrony Środowiska, pp. 52 (in Polish)
- Kulik-Kuziemska I., 1996, *Littoral of Żarnowiec Lake [in:] The state of Lake Żarnowieckie after ten years exploitation by the pumped-storage Żarnowiec Hydropower Plant*, Monografie

- Komitetu Gospodarki Wodnej PAN, No. 11, Ed. Majewski W., Politechnika Warszawska, Warszawa: 87-95, (in Polish with Engl. summ.)
- Lafferty K.D., 1997, *Environmental parasitology: what can parasites tell us about human impacts on the environment?*, Parasit. Today 13: 251-255
- Landsberg J.H., Blakesley B.A., Reese R.O., Mcrae G., Forstchen P.R., 1998, *Parasites of fish as indicators of environmental stress*, Environ. Monit. Assess., 51: 211-232
- Lange W., 1993, *Anthropogenic transformation of lake systems* [in:] *Methods for physical limnological studies*, Ed. Lange W., Gdańsk, Uniwersytet Gdański, pp: 164-168 (in Polish)
- Lange W., Nowiński K., 2006, *State of the aquatic environment of selected lakes in the upper Radunia drainage basin* [in:] *The Raduńskie Lakes. Anthropogenic transformations and directions for protection*, Eds. Wołos A., Nedoszytko B., IRS, Olsztyn, pp: 21-25, (in Polish)
- Legendre P., Legendre L., 2003, *Numerical ecology. Developments in environmental modelling, no 20*, Elsevier, Amsterdam, 853 pp
- Llewellyn J., 1956, *The host-specificity, micro-ecology, adhesive attitudes, and comparative morphology of some trematode gill parasites*, J. Mar. Biol. Assoc. UK, 35: 113-127
- Loot G., Reyjol Y., Poulet N., Simkova A., Blanchet S., Lek S., 2007, *Effects of small weirs on fish parasite communities*, Parasitol. Res. 101: 1265-1276
- Maamouri F., Gargouri L., Ould Daddah M., Bouix G., 1999, *Occurrence of Anguillicola crassus (Nematoda, Anguillicolidae) in the Ichkeul Lake (Northern Tunisia)*, Bull. Eur. Ass. Fish Pathol., 19: 17-19
- MacKenzie K., Williams H.H., Williams B., McVicar A.H., Siddall R., 1995, *Parasites as indicators of water quality and the potential use of helminth transmission in marine pollution studies*, Adv. Parasitol., 35: 86-144
- Magurran A.E., 1988, *Ecological diversity and its measurement*, New Jersey, Princeton University Press, pp. 179
- Magurran A.E., 2004, *Measuring biological diversity*, Oxford, Blackwell Publishing, pp. 256
- Mañillo P.A., Vich M.A., Salvadó H., Marqués A., Gracia M.P., 2005, *Parasites of Anguilla anguilla (L.) from three coastal lagoons of the River Ebro delta (Western Mediterranean)*, Acta Parasitol., 50: 156-160
- Malmberg G., 1970, *The excretory systems and the marginal hooks as a basis for the systematics of Gyrodactylus (Trematoda, Monogenea)*, Ark. Zool., Serie 2, 23: 1-235
- Marcogliese D.J., 1995, *Comparison of parasites of mummichogs and sticklebacks from brackish and freshwater ponds on Sable Island, Nova Scotia*, Am. Midl. Nat., 133: 333-343
- Marques J.F., Santos M.J., Cabral H.N., 2009, *Zoogeographical patterns of flatfish (Pleuronectiformes) parasites in the Northeast Atlantic and the importance of the Portuguese coast as a transitional area*, Sci. Mar., Supplementary material, 73: 1-5
- Maślanka W., Barańczak J., 2007, *Lake Raduńskie Dolne*, Limnol. Res., 4: 239-245, (in Polish)
- Mierzejewska K., Własow T., Dzika E., 2006, *Fish monogeneans from a shallow, eutrophic Oświn Lake in Poland*, Wiad. Parazytol., 52: 37-47
- Mladineo I., 2005, *Parasite communities of Adriatic cage-reared fish*, Dis. Aquat. Org. 64: 77-83
- Moravec F., 1994, *Parasitic nematodes of freshwater fishes of Europe*, Praha, Academia, pp. 473
- Moravec F., 1996, *Aquatic invertebrates (snails) as new paratenic hosts of Anguillicola crassus (Nematoda: Dracunculoidea) and the role of paratenic hosts in the life cycle of this parasite*, Dis. Aquat. Org., 27: 237-239
- Moravec F., 2006, *Dracunculoid and anguillicoloid nematodes parasitic in vertebrates*, Praha, Academia, pp. 634
- Moravec F., Gelnar M., Ergens R., Scholz T., 1997, *Metazoan parasites of fishes from the section of the Vltava River supposed to be affected by the operation of the Temelin nuclear electric power-station, Czech Republic*, Acta Soc. Zool. Bohem., 61: 65-76

- Moravec F., Škoriková B., 1998, *Amphibians and larvae of aquatic insects as new paratenic hosts of Anguillicola crassus (Nematoda: Dracunculoidea), a swimbladder parasite of eels*, Dis. Aquat. Org., 34: 217-222
- Morozińska-Gogol J., 2007, *Metazoan parasites of fish from the Lebsko Lagoon, Balt. Coast. Zone 11*: 51-58
- Morozińska-Gogol J., 2008, *A check-list of parasites of percid fishes (Actinopterygii: Percidae) from the estuaries of the Polish coastal zone*, Helminthologia 45: 196-203
- Moser M., Cowen R.K., 1991, *The effects of periodic eutrophication on parasitism and stock identification of Trematopus bernacchii (Pisces: Nototheniidae) in McMurdo Sound Antarctica*, J. Parasitol., 77: 551-556
- Moyle P.B., Cech J.J., 1988, *Fishes. An introduction to ichthyology*, Englewood Cliffs, New Jersey, Prentice Hall, pp. 559
- Myjak P., Szostakowska B., Wyszynski M., Pietkiewicz H., 1996, *Occurrence of Anisakis simplex larvae in herring from the southern Baltic Sea. Proceedings of Polish-Swedish Symposium on Baltic coastal fisheries, resources and management*, Gdynia, Poland: 137-141
- Nagibina, L.F., 1961, *Parasitofauna of fish of Novoe Vygozero (New Vygozero Lake) [in:] Bulletin of the All-union Scientific Research Institute Fresh-water Fisheries, vol. 42-Parasites and Diseases of Fish*, Ed., Petrushevskii G.K., Jerusalem, Translated from Russian, Translation Israel Program for Scientific: 127-140
- Narwojsz A., 2000, *Hydrography of the Park area and its environment [in:] Materials for nature monographs of Gdańsk region*, Ed. Gerstmannowa E., Gdańsk, Marpress, 3: 18-22
- Neumann W., 1985, *Schwimmblassenparasit Anguillicola bei Aalen*, Fisch, Teichwirt 11: 322
- Niewiadomska K., 1988, *Diplostomum metacercariae (Digenea) in fish of the Dgál Wielki and Warniak lakes: D. numericum sp.n. and D. baeri Dubois, 1937, with comments on the synonymy of this species*, Acta Parasitol., 33: 7-24
- Niewiadomska K., 1996, *The genus Diplostomum – taxonomy, morphology and biology*, Acta Parasitol., 41: 55-66
- Niewiadomska K., 2003, *Parasites of Polish fish (identification key). Trematoda – Digenea*, Warszawa, Polskie Towarzystwo Parazytologiczne, pp. 169 (in Polish)
- Niewiadomska K., Pojmańska T., Machnicka B., Czubaj A., 2001, *Foundations of fish biology*, Warszawa, PWN, pp. 515 (in Polish)
- Obiekiezie A.I., Lick R., Kerstan S., Möller H., 1992, *Larval nematodes in stomach wall granulomas of smelt Osmerus eperlanus from the German North Sea coast*, Dis. Aquat. Org., 12: 177-183
- Obolewski K., Strzelczak A., 2008, *MR&CT analysis of the qualitative and quantitative structure of macrozoobenthos in selected oxbow lakes of Northern Poland*, Ocean. Hydrob. Stud., 37: 97-104
- Odum E.P., 1971, *Fundamentals of ecology*, Philadelphia, Saunders, pp. 574
- Okulewicz J., 1984, *Bird trematodes of Lower Silesia II. Intestinal trematodes of red-throated diver (Gavia stellata Pont.)*, Wiad. Parazytol., 30: 503-519, (in Polish with Engl. summ.)
- Ondračková M., Šimková A., Gelnar M., Juranda P., 2004, *Posthodiplostomum cuticola (Digenea: Diplostomatidae) in intermediate fish hosts: factors contributing to the parasite infection and prey selection by the definitive bird host*, Parasitology 129: 761-770
- Opuszyński K., 1983, *Foundations of fish biology*, Warszawa, PWRiL, pp. 590, (in Polish)
- Overstreet R.M., 1993, *Parasitic diseases of fishes and their relationship with toxicants and other environmental factors [in:] Pathology of Marine and Estuarine Organisms, (Advances in Fisheries Science)*, Eds. Couch J.A., Fourine J.W., Boca Raton, CRC Press: 111-156
- Palm H., Dobberstein R.C., 1999, *Occurrence of trichodinid ciliates (Peritricha: Urceolariidae) in the Kiel Fjord, Baltic Sea, and its possible use as a biological indicator*, Parasitol. Res., 85: 726-732



- Paperna I., 1995, *Digenea (Phylum Platyhelminthes)* [in:] Ed. Woo P.T.K., *Fish diseases and disorders, vol.1, Protozoan and metazoan infection*, Wallingford, CAB International, pp. 329-389
- Piasecki W., 1993, *Crustacean parasites from three fish species from the Odra river estuary, Poland*, *Acta Ichthyol. Piscat.*, 23: 77-87
- Piasecki W., 1995, *Life cycle of Caligus elongatus von Nordmann, 1832 (Crustacea, Copepoda, Siphonostomatoidea)*, Szczecin, Akademia Rolnicza, Rozprawy 165: 1-69, (in Polish with Engl. summ.)
- Piasecki W, Kuźmińska E., 2007, *Developmental stages of Achtheres percarum (Crustacea: Copepoda), parasitic on European perch, Perca fluviatilis (Actinopterygii: Perciformes)*, *Acta Ichthyol. Piscat.*, 37: 117-128
- Pike A.W., Wadsworth S.L., 1999, *Seallice on salmonids: their biology and control*, *Adv. Parasitol.*, 44: 234-337
- Pliński M., Wnorowski T., 1993, *The plant communities of lake Żarnowieckie and its flood zone during the initial operation of the pumped-storage power station, Gdańsk*, Uniwersytet Gdański, pp. 130, (in Polish with Engl. summ.)
- Pojmańska T., 1993a, *Possibilities of parasite transfer between local and acclimated cyprinid fishes in pond culture*, *Kom. Ryb.*, 1: 6-8, (in Polish)
- Pojmańska T., 1993b, *The review of ecological terms used contemporarily in parasitology*, *Wiad. Parazyt.*, 39: 285-297, (in Polish with Engl. summ.)
- Pojmańska T., Cielecka D., 2001, *Tapeworms (Cestoda) of the aquatic environment*, *Fauna Słodkowodna Polski* 33. Łódź, Uniwersytet Łódzki, pp. 383, (In Polish)
- Pojmańska T., Grabda-Kazubska B., Kazubski S.L., Machalska J., Niewiadomska K., 1980, *Parasite fauna of five fish species from the Konin lakes complex, artificially heated with thermal effluents, and from Gopło lake*, *Acta Parasitol. Pol.*, 27: 319-357
- Pojmańska T., Niewiadomska K., Okulewicz A., 2007, *Parasitic helminths of Poland – species, hosts, grey areas*, Warszawa, Polskie Towarzystwo Parazytologiczne, pp. 360, (in Polish with Engl. summ.)
- Popiołek M., Okulewicz J., 2000, *Helminths fauna of fishes in the Mała Panew river drainage basin*, *Wiad. Parazytol.*, 46: 63-73, (in Polish with Engl. summ.)
- Poulin R., 2007, *Evolutionary ecology of parasites*, Oxford, Princeton University Press Princeton, pp. 332
- Pritchard M.H., Kruze G., O.W., 1982, *The collection and preservation of animal parasites*, Lincoln, London, University of Nebraska, Technical Bulletin No. 1, pp. 141
- Prost M., 1959, *Investigations on the influence of salinity on the Monogenoidea fauna of fishes*, *Acta Parasitol. Pol.*, 7: 615-630, (in Polish with Engl. summ.)
- Regional Inspectorate for Environmental Protection, 2002a, *Evaluation of the purity of the waters of the Lake Żarnowieckie based on studies conducted in 2002*, Gdańsk, pp. 80, (in Polish)
- Regional Inspectorate for Environmental Protection, 2002b, *Evaluation of the purity of the waters of the Lake Raduńskie Dolne based on studies conducted in 2002*, Gdańsk, pp. 54, (in Polish)
- Rhode K., 1982, *Ecology of marine parasites*, St. Lucia, University of Queensland Press, pp. 245
- Roberts R.J., 2001, *The parasitology of teleosts* [in:] *Fish pathology*, Ed. Roberts R.J., London, W.B.Saunders, pp: 254-296
- Rokicki J., 1975, *Helminth fauna of fishes of the Gdańsk Bay (Baltic Sea)*, *Acta Parasitol., Pol.*, 23: 37-84
- Rokicki J., 1995, *Changes in the parasite fauna of cod Gadus morhua L. in the Gdansk Bay*, Polish-Swedish Symposium on Baltic cod, Gdynia, Poland, Meddelande Från Havsfiskelaboratoriet 327: 131-139

- Rokicki J., 2005, *The possibility of completing the life cycle of Hysterothylacium aduncum (Rudolphi, 1802) and Contracaecum rudolphii (Hartwich, 1964) (Nematoda) at the waters of Vistula Lagoon*, Wiad. Parazytol., 51: 239-241, (in Polish with Engl. summ.)
- Rolbiecki L., 2001, *The role of copepods as intermediate tapeworm hosts in fishes of the Vistula Lagoon* [in:] *Arthropods, parasites and hosts*, Eds. Buczek A., Błaszak Cz., Lublin, KGM: 135-144, (in Polish with Engl. summ.)
- Rolbiecki L., 2002a, *A rapid method for preparing semipermanent glycerol-jelly parasite mounts*, Wiad. Parazytol., 48: 87-88, (in Polish with Engl. summ.)
- Rolbiecki L., 2002b, *On the role of paratenic hosts in the life cycle of the nematode Anguillicola crassus in the Vistula Lagoon, Poland*, Acta Ichthyol. Piscat. 32: 109-116
- Rolbiecki L., 2003, *Diversity of the parasite fauna of cyprinid (Cyprinidae) and percid (Percidae) fishes in the Vistula Lagoon, Poland*, Wiad. Parazytol., 49: 125-164
- Rolbiecki L., 2004a, *Can the dab (Limanda limanda) be a paratenic host of Anguillicola crassus (Nematoda; Dracunculoidea)? The Gulf of Gdańsk and Vistula Lagoon (Poland) example*, Wiad. Parazytol., 50: 317-322.
- Rolbiecki L., 2004b, *Larvae of Anguillicola crassus (Nematoda, Dracunculoidea) in stickleback (Gasterosteus aculeatus) and smelt (Osmerus eperlanus) from the Gulf of Gdańsk and the Vistula Lagoon*, Zool. Pol., 49: 29-35
- Rolbiecki L., 2004c, *Habitat preferences of the parasitic copepod Ergasilus sieboldi (Ergasilidae) in the lake trout Salmo trutta m. lacustris (Linnaeus, 1758) in Lake Wdzydze* [in:] *Parasitic and allergic arthropods – medical and sanitary significance*, Eds. Buczek A., Błaszak C., Lublin, Liber: 87-92, (in Polish with Engl. summ.)
- Rolbiecki L., 2006a, *Parasites of the round goby, Neogobius melanostomus (Pallas, 1811), an invasive species in the Polish fauna of the Vistula Lagoon ecosystem*, Oceanologia 48: 545-561
- Rolbiecki L., 2006b, *Correlation between the occurrence of parasites and body length of roach, carp bream, European perch, zander, and ruffe in the Vistula Lagoon estuary*, Ocean. Hydrob. Stud., 35: 257-267
- Rolbiecki L., 2007, *The application of acetic acid and benzyl alcohol in parasitological preparations – advantages and disadvantages*, Wiad. Parazytol., 53: 347-349, (in Polish with Engl. summ.)
- Rolbiecki L., Bartel R., Rokicki J., 2008, *The nematode parasite, Anguillicola crassus Kuwahara, Niimi et Itagaki, and the monogenean gill parasite, Pseudodactylogyrus anguillae (Yin et Sproston), in eel, Anguilla anguilla (L.), fry*, Arch. Pol. Fish., 16: 221-226
- Rolbiecki L., Izdebska J., 2003, *Metric variability of the common fish-louse Argulus foliaceus (Linnaeus, 1758) (Branchiura, Crustacea) from the Raduńskie Lake, The Kaszubskie Lake-district* [in:] *Arthropods and hosts*, Eds. Buczek A., Błaszak Cz., Lublin, Liber: 83-90, (in Polish with Engl. summ.)
- Rolbiecki L., Janc A., Rokicki J., 2001, *Stickleback as a potential paratenic host in the Anisakis simplex life cycle in the Baltic Sea: results of experimental infection*, Wiad. Parazytol., 47: 257-262
- Rolbiecki L., Rokicki J., 2000, *The topographic specificity of Achtheres percarum Nordmann, 1932 (Copepoda: Lernaepodidae) in the pike-perch Stizostedion lucioperca (L., 1758)*, Crangon 4: 47-53
- Rolbiecki L., Rokicki J., 2002, *III-stage Anisakis simplex (Rudolphi, 1809) (Nematoda; Anisakidae) larvae in herring caught in autumn from the Polish part of the Vistula Lagoon*, Acta Sci. Polon., Piscaria 1: 105-110
- Rolbiecki L., Rokicki J., 2005, *Anguillicola crassus – an alien nematode species from the swim bladder of eel (Anguilla anguilla) in the polish zone of the Southern Baltic and the waters of Northern Poland*, Ocean. Hydrob. Stud., 34: 121-136

- Rolbiecki L., Rokicki J., Szugaj K., 2002, *Variability of perch, Perca fluviatilis L., helminth fauna in the Gulf of Gdańsk, Baltic Sea*, Ocean. Stud., 31: 43-50
- Rolbiecki L., Wawer E., Wawer A., Rokicki J., 2003, *The hairworm Gordius aquaticus (Linnaeus, 1758) from rainbow trout, Oncorhynchus mykiss, from the Kashubian Lake District*, Zjazd Polskiego Towarzystwa Zoologicznego – Zoologia na progu XXI wieku, Toruń, Poland: 221-222, (in Polish)
- Rückert S., Klimpel S., Palm H.W., 2007, *Parasite fauna of bream Abramis brama and roach Rutilus rutilus from a man-made waterway and a freshwater habitat in northern Germany*, Dis. Aquat. Org., 74: 225-233
- Rząd I., Kavetska K., Królaczyk K., 2008, *Digenea układu pokarmowego Gavia stellata (Pontoppidan, 1763) i Gavia arctica (Linnaeus, 1758) z Pomorza Zachodniego*, Wiad. Parazytol., 54: 353-354
- Salgado-Maldonado G., Kennedy C.R., 1997, *Richness and similarity of helminth communities in the tropical cichlid fish Cichlasoma urophthalmus from the Yucatan Peninsula, Mexico*, Parasitology 114: 581-590.
- Sasal P., Taraschewski H., Valade P., Grondin H., Wielgoss S., Moravec F., 2008, *Parasite communities in eels of the Island of Reunion (Indian Ocean): a lesson in parasite introduction*, Parasitol. Res., 102:1343–1350
- Schmidt-Rhaesa A., 1997, *Nematomorpha [in:] Süßwasserfauna von Mitteleuropa*, vol. 4 (4), Eds. Schwoerbel J., Zwick P., Stuttgart, Gustav Fischer, pp.128
- Scholz T., 1985, *On the occurrence of endoparasitic helminths in perch (Perca fluviatilis L.) from the Mácha lake fishpond system, Czechoslovakia*, Acta Univ. Carol. Biol., 5-6: 301-318
- Scholz T., Hanzelová V., Škeříková A., Shimazu T., Rolbiecki L., 2007, *An annotated list of species of the Proteocephalus Weinland, 1858 aggregate sensu de Chambrier et al. (2004) (Cestoda: Proteocephalidea), parasites of fishes in the Palearctic Region, their phylogenetic relationships and a key to their identification*, Syst. Parasitol., 67: 139-156
- Sobecka E., 2007, *Parasites of two subspecies of the atlantic cod: Gadus morhua morhua L. and Gadus morhua callarias from the selected regions of Atlantic and Baltic Sea*, Szczecin, Akademia Rolnicza, Rozprawy 245:1-82, (in Polish)
- Sobecka E., Słomińska M., 2007, *Species richness, diversity and specificity of the parasites of bream Abramis brama (L.) and perch Perca fluviatilis L. in the estuary of the Odra River, Poland*, Helminthologia 44: 188-192
- Sulgostowska T., 1988, *Changes in the parasitic fauna of flounder, Platichthys flesus (L.) in relation to the degree of pollution of south-eastern Baltic*, Wiad. Parazytol., 34: 591-594, (in Polish)
- Sures B., 2004, *Environmental parasitology: relevancy of parasites in monitoring environmental pollution*, Trends Parasitol., 20: 170-177
- Sures B., Sidall R., Taraschewski H., 1999, *Parasites as accumulation indicators of heavy metal pollution*, Parasitol. Today 15: 16-21
- Székely Cs., 1995, *Dynamics of Anguillicola crassus (Nematoda: Dracunculoidea) larval infection in paratenic host fishes of Lake Balaton, Hungary*, Acta Vet. Hung., 43: 401-422
- Szmeja J., 2006, *Assumptions for the protection of the Raduńskie lakes [in:] The Raduńskie Lakes. Anthropogenic transformations and directions for protection*, Eds. Wolos A., Nedoszytko B., Olsztyn, IRS: 17-20, (in Polish)
- Szostakowska B., Myjak P., Wyszynski M., Pietkiewicz H., Rokicki J., 2005, *Prevalence of anisakin nematodes in fish from Southern Baltic Sea*, Pol. J. Microbiol., 54: 41-45
- Šimková A., Sitko J., Okulewicz A., Morand S., 2003, *Occurrence of intermediate hosts and structure of digenean communities of the black-headed gull*, Parasitology 126: 69-78
- Taraschewski H., 2006, *Hosts and parasites as aliens*, J. Helminthol., 80: 99-128

- Terlecki J., 2000, *European perch Perca fluviatilis Linnaeus, 1758* [in:] *The freshwater fishes of Poland*, Ed. Brylińska M., Warszawa, PWN: 455-461
- Thomas K., Ollevier F., 1992, *Paratenic hosts of the swimbladder nematode Anguillicola crassus*, Dis. Aquat. Org., 13: 165-174
- Tunowski J., Murawa W., 1996, *Pelagic zooplankton* [in:] *The state of Lake Żarnowieckie after ten years exploitation by the pumped-storage Żarnowiec Hydropower Plant*, Monografie Komitetu Gospodarki Wodnej PAN, No. 11, Ed. Majewski W., Politechnika Warszawska, Warszawa: 113-125, (in Polish with Engl. summ.)
- Valtonen E.T., Haaparanta A., Hoffmann R.W., 1994, *Occurrence and histological response of Raphidascaris acus (Nematoda: Ascaridoidea) in roach from four lakes differing in water quality*, Int. J. Parasitol., 24: 197-206
- Valtonen E.T., Holmes J.C., Aronen J., Rautalahti I., 2003, *Parasite communities as indicators of recovery from pollution: parasites of roach (Rutilus rutilus) and perch (Perca fluviatilis) in Central Finland*, Parasitology 126: S43-S52
- Valtonen E.T., Holmes J.C., Koskivaara M., 1997, *Eutrophication, pollution, and fragmentation: effects on parasite communities in roach (Rutilus rutilus) and perch (Perca fluviatilis) in four lakes in central Finland*, Can. J. Fish. Aquat. Sci., 54: 572-585
- Wächtler K., Dreher-Mansur M.C., Richter T., 2001, *Larval types and early postlarval biology in naiads (Unionoida)* [in:] *Ecology and evolution of the freshwater mussels Unionoida*, Eds. Bauer G., Wächtler K., Ecological Studies 145: 93-125
- Waluga D., Własow T., 1988, *The occurrence of parasites in bream (Abramis brama L.), roach (Rutilus rutilus L.) and pike perch (Stizostedion lucioperca L.) in the Włocławek dam reservoir on the river Vistula*, Wiad. Parazytol., 34: 65-75, (in Polish with Engl. summ.)
- Wierzbicka J., Wierzbicki K., Piasecki W., Śmietana P., 2005, *A comparative study on the parasite fauna of perch, Perca fluviatilis L., collected from a freshwater coastal lake, brackish-water Baltic Sea, and the interconnecting canal*, Wiad. Parazytol., 51: 295-302
- Wilkońska H., 1996, *Fish communities in shallow littoral* [in:] *The state of Lake Żarnowieckie after ten years exploitation by the pumped-storage Żarnowiec Hydropower Plant*, Monografie Komitetu Gospodarki Wodnej PAN, No. 11, Ed. Majewski W., Politechnika Warszawska, Warszawa, 11: 133-141, (in Polish with Engl. summ.)
- Williams H., Jones A., 1994, *Parasitic worms of fish*, London, Bristol, Taylor & Francis, pp. 593
- Wojtasik B., 2007, *Meiobenthic assemblages in the lakes of the Upper Radunia catchment*, Limnol. Res., 5: 131-144, (in Polish with Engl. summ.)
- Wong P.L., Anderson R.C., 1982, *The transmission and development of Cosmocephalus obvelatus (Nematoda: Acuarioidea) of gulls (Laridae)*, Can. J. Zool., 60: 1426-1440
- Zalewski W., 2000, *Threat of the environment and its condition in the region of Nadmorski Landscape Park* [in:] *Materials for nature monographs of Gdańsk region*, Ed. Gerstmannowa E., Gdańsk, Marpress, 3: 92-111, (in Polish)
- Załachowski W., 2000, *Roach Rutilus rutilus (Linnaeus, 1758)* [in:] *The freshwater fishes of Poland*, Ed. Brylińska M., PWN, Warszawa: 273-278, (in Polish)
- Zander C.D., Reimer W., 2002, *Parasitism at the ecosystem level in the Baltic Sea*, Parasitology 124: S119-S135
- Zar J. H., 1984, *Biostatistical analysis*, Englewood Cliffs, Prentice-Hall, 718 pp
- Złotorzycka J., Lonc E., Majewska A.C., Okulewicz A., Pojmańska T., Wędrychowicz H., 1998, *Dictionary of parasitology*, Polskie Towarzystwo Parazytologiczne, Warszawa, pp.174, (in Polish)